



***OWNER'S MANUAL  
F85 Treadmill***

*Please carefully read this entire manual  
before operating your new treadmill.*

***ATTENTION:*** *Before returning your Sole product to any retailer, or if you require any assistance with assembly or technical support please call us first for assistance at 866-780-7653. Thank you for your Sole purchase.*

# TABLE OF CONTENTS

<u>Product Registration</u>	<u>1</u>
<u>Important Safety Instructions</u>	<u>2</u>
<u>Important Electrical Information</u>	<u>3</u>
<u>Important Operation Instructions</u>	<u>4</u>
<u>Assembly instructions</u>	<u>8</u>
<u>Folding Instructions</u>	<u>12</u>
<u>Transport Instructions</u>	<u>12</u>
<u>Operation of Your New Treadmill</u>	<u>13</u>
<u>Bluetooth® Connectivity</u>	<u>20</u>
<u>Charging Function</u>	<u>21</u>
<u>General Maintenance</u>	<u>25</u>
<u>Service Checklist - Diagnosis Guide</u>	<u>28</u>
<u>Manufacturer's Limited Warranty</u>	<u>30</u>



**WARNING:** This product can expose you to chemicals including Toluene and Acrylamide which are known to the State of California to cause Cancer and birth defects or other reproductive harm. For more information, go to [www.P65Warnings.ca.gov](http://www.P65Warnings.ca.gov)

**Before returning your Sole product to any retailer, or if you require any assistance with assembly or technical support please call us first for assistance at 866-780-7653. Thank you for your Sole purchase.**

# SOLE

## FITNESS

### CONGRATULATIONS ON YOUR NEW TREADMILL AND WELCOME TO THE SOLE FAMILY!

Thank you for your purchase of this quality treadmill from **SOLE**. Your new treadmill has been manufactured by one of the leading fitness manufacturers in the world and is backed by one of the most comprehensive warranties available. **SOLE** will do all we can to make your ownership experience as pleasant as possible for many years to come.

If there is a question as to where to obtain service, contact our service department at **866-780-7653**.

Please take a moment at this time to record below the name of the dealer, their telephone number, and the date of purchase for easy contact in the future. We appreciate your confidence in **SOLE** and we will always remember that you are the reason that we are in business. Please complete and mail your registration card today and enjoy your new treadmill.

Yours in Health,  
**SOLE** Fitness

Name of Dealer \_\_\_\_\_

Telephone Number of Dealer \_\_\_\_\_

Purchase Date \_\_\_\_\_

## PRODUCT REGISTRATION

**RECORD YOUR SERIAL NUMBER** Please record the Serial Number of this fitness product in the space provided below.

**Serial Number** \_\_\_\_\_

### REGISTER YOUR PURCHASE

The self-addressed product registration card must be completed in full and returned to **SOLE**. You can also go to [www.soletreadmills.com](http://www.soletreadmills.com) under the support tab to register online.



# IMPORTANT SAFETY INSTRUCTIONS

**WARNING** - Read all instructions before using this appliance.

**DANGER** - To reduce the risk of electric shock disconnect your SOLE treadmill from the electrical outlet prior to cleaning and/or service work.

**WARNING** - To reduce the risk of burns, fire, electric shock, or injury to persons, install the treadmill on a flat level surface with access to a 120-volt, 15-amp grounded outlet with only the treadmill plugged into the circuit.

**DO NOT USE AN EXTENSION CORD UNLESS IT IS A 14AWG OR BETTER, WITH ONLY ONE OUTLET ON THE END: DO NOT ATTEMPT TO DISABLE THE GROUNDED PLUG BY USING IMPROPER ADAPTERS, OR IN ANY WAY MODIFY THE CORD SET.**

A serious shock or fire hazard may result along with computer malfunctions. See Grounding Instructions, page 3.

- Do not operate treadmill on deeply padded, plush or shag carpet. Damage to both carpet and treadmill may result.
- Do not block the rear of the treadmill. Provide a minimum of 3 1/2 feet clearance between the rear of the treadmill and any fixed object.
- Keep children under the age of 13 away from this machine. There are obvious pinch points and other caution areas that can cause harm.
- Keep hands away from all moving parts.
- Never operate the treadmill if it has a damaged cord or plug. If the treadmill is not working properly, call your dealer.
- Keep the cord away from heated surfaces.
- Do not operate where aerosol spray products are being used or where oxygen is being administered. Sparks from the motor may ignite a highly gaseous environment.
- Never drop or insert any object into any openings.
- Do not use outdoors.
- To disconnect, turn all controls to the off position, remove tether cord, then remove the plug from the outlet.
- Do not attempt to use your treadmill for any purpose other than for the purpose it is intended.
- The pulse sensors are not medical devices. Various factors, including the user's movement, may affect the accuracy of heart rate readings. The pulse sensors are intended only as exercise aids in determining heart rate trends in general.
- Use handrails provided; they are for your safety.
- Wear proper shoes. High heels, dress shoes, sandals or bare feet are not suitable for use on your treadmill. Quality athletic shoes are recommended to avoid leg fatigue.
- This appliance is not intended for use by persons with reduced physical, sensory or mental capabilities, or lack of experience and knowledge, unless they have been given supervision or instruction concerning use of the appliance by a person responsible for their safety.

**Remove tether cord after use to prevent unauthorized treadmill operation.**

**SAVE THESE INSTRUCTIONS - THINK SAFETY!**

# IMPORTANT ELECTRICAL INSTRUCTIONS

## **WARNING!**

Route the power cord away from any moving part of the treadmill including the elevation mechanism and transport wheels.

**NEVER** remove any cover without first disconnecting AC power.

If voltage varies by ten percent (10%) or more, the performance of your treadmill may be affected. Such conditions are not covered under your warranty. If you suspect the voltage is low, contact your local power company or a licensed electrician for proper testing.

**NEVER** expose this treadmill to rain or moisture. This product is NOT designed for use outdoors, near a pool or spa, or in any other high humidity environment. The maximum operating temperature specification is 40 degrees C, and humidity is 95% non-condensing (no water drops forming on surfaces).

**Circuit breakers:** Avoid AFCI/GFCI circuit breakers if possible. These breakers may trip occasionally during exercise because of the high inrush currents of the treadmill drive electronics and motor. This is an issue that affects all treadmill brands.

New laws in your area may require these breakers. If you do have these breakers and outlets in your home, and are experiencing nuisance tripping, you should check if there are any other devices plugged into the same circuit. Some examples of devices that may also cause tripping are fluorescent lights with electronic ballasts, coffee maker, space heater, hair drier. Optimally the treadmill should be the only device plugged into the circuit.

Our treadmills have surge suppressors built in to help avoid nuisance tripping. We have tested several AFCI/GFCI breakers and outlets with our products. Brands we have tested are: Eaton (Cutler Hammer Series), Leviton (Smart lock pro) and Schneider Electric (Canadian home series). These breakers do not trip in our testing, when connected to our treadmills, as long as no other devices are plugged into the same circuit.

# GROUNDING INSTRUCTIONS

**This product must be grounded.** If the treadmill should malfunction or breakdown, grounding provides a path of least resistance for electric current, reducing the risk of electric shock. This product is equipped with a cord having an equipment-grounding plug. The plug must be plugged into an appropriate outlet that is properly installed and grounded in accordance with all local codes and ordinances.

**DANGER - Improper connection of the equipment-grounding conductor can result in a risk of electric shock. Check with a qualified electrician or serviceman if you are in doubt as to whether the product is properly grounded. Do not modify the plug provided with the product if it will not fit the outlet; have a proper outlet installed by a qualified electrician.**

This product is for use on a nominal 120-volt circuit, and has a grounding plug that looks like the plug illustrated below. A temporary adapter that looks like the adapter illustrated below may be used to connect this plug to a 2-pole receptacle as shown below if a properly grounded outlet is not available. The temporary adapter should be used only until a properly grounded outlet, (shown below) can be installed by a qualified electrician. The green colored rigid ear-lug, or the like, extending from the adapter, must be connected to a permanent ground such as a properly grounded outlet box cover. Whenever the adapter is used, it must be held in place by a metal screw.

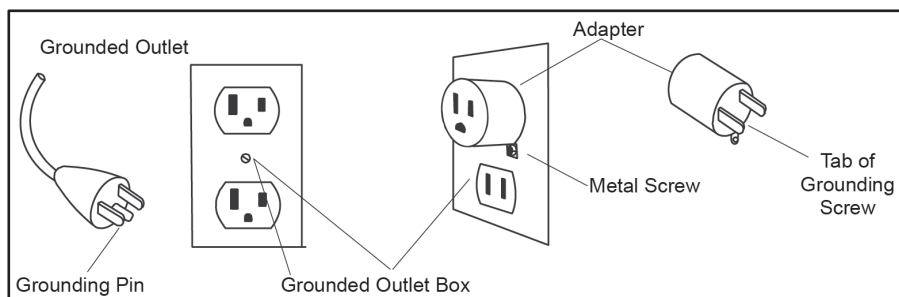

## IMPORTANT OPERATION INSTRUCTIONS

- **NEVER** operate this treadmill without reading and completely understanding the results of any operational change you request from the computer.
- Understand that changes in speed and incline do not occur immediately. Set your desired speed on the computer console and release the adjustment key. The computer will obey the command gradually.
- **NEVER** use your treadmill during an electrical storm. Surges may occur in your household power supply that could damage treadmill components. Unplug the treadmill during an electrical storm as a precaution.
- Use caution while participating in other activities while walking on your treadmill; such as watching television, reading, etc. These distractions may cause you to lose balance or stray from walking in the center of the belt; which may result in serious injury.
- **NEVER** mount or dismount the treadmill while the belt is moving. **SOLE** treadmills start at a very low speed and it is unnecessary to straddle the belt during start up. Simply standing on the belt during slow acceleration is proper after you have learned to operate the unit.
- Always hold on to a handrail or hand bar while making control changes (incline, speed, etc.).
- Do not use excessive pressure on console control keys. They are precision set to function properly with little finger pressure. Pushing harder is not going to make the unit go faster or slower. If you feel the buttons are not functioning properly with normal pressure contact your **SOLE** dealer.

## IMPORTANT SAFETY INSTRUCTIONS

A safety tether cord is provided with this unit and should be used at all times. It is for your safety should you fall or move too far back on the tread-belt. Pulling this safety tether cord will stop tread-belt movement.

### To Use:

1. Place the safety key into position on the console control head. Your treadmill will not start and operate without this. Removing the safety key also secures the treadmill from unauthorized use.
2. Fasten the plastic clip onto your clothing securely to assure good holding power.  
**Note:** *The clip should be attached securely to make certain it does not come off. Be familiar with its function and limitations. The treadmill will stop, depending on speed, with a one to two step coast anytime the safety key is pulled off the console. Use the red **Stop** switch in normal operation.*
3. If the console displays "Safety key removed, machine stopped, click Replace the key to Operate", put the Safety key back to continue using the treadmill.

# IMPORTANT SAFETY INSTRUCTIONS

## READ BEFORE UNPACKING YOUR FOLDING TREADMILL

Serious injury could occur if this folding treadmill is not unpacked properly.

There is a deck restraint SHIPPING strap installed around the treadmill base that prevent the treadmill from unfolding accidentally during shipping. If this strap is not removed properly the treadmill could spring open unexpectedly and cause injury if someone is standing near the treadmill when the strap is removed.

To ensure your personal safety during removal of the shipping strap please make sure the treadmill is positioned flat on the ground, in the orientation it would be in if you were using the treadmill. Do not tilt the treadmill up on its side while removing the shipping strap: this could cause the treadmill's folding mechanism to spring open. To remove the strap, pull up on the strap and cut it with a pair of scissors.

There is a safety pin locked on the treadmill base that prevents the treadmill from unfolding accidentally during shipping. This safety pin has to be removed before powering on or using the incline function to avoid any damages to the machine. When removing the safety pin, pull it away from the treadmill base completely.

## PREVENTATIVE MAINTENANCE CHART

Vacuum Under Motor Cover & Check Wiring (Every Other Month)	Clean & Inspect Deck for Lubrication (Every Other Month)	Lubricate Deck (Every 90 hours or sooner if dry)	Inspect Belt Tracking (Monthly) Adjust if necessary	Date

# F85 ASSEMBLY PACK CHECKLIST

## 3 HARDWARE STEP 3

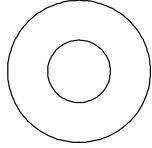

#106.  $\text{\O} 3/8" \times \text{\O} 19 \times 1.5T$   
Flat Washer (8 pcs)

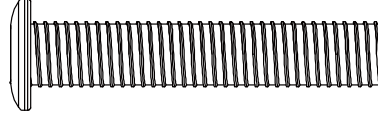

#86.  $3/8" \times \text{UNC}16 \times 2"$   
Flat Head Socket Bolt (8 pcs)

## 4 HARDWARE STEP 4



#113.  $\text{\O}10 \times 1.5T$   
Split Washer (4 pcs)

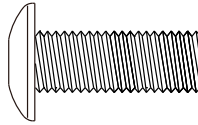

#139.  $3/8" \times 1/2"$   
Button Head Socket Bolt (4 pcs)

## 5 HARDWARE STEP 5

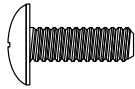

#127.  $M5 \times 15m/m$   
Phillips Head Screw (4 pcs)

## 6 HARDWARE STEP 6

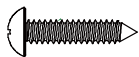

#175.  $3.5 \times 16m/m$   
Sheet Metal Screw (4 pcs)

# 7 HARDWARE STEP 7

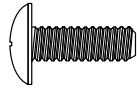

**#127.** M5 x 15m/m\_  
Phillips Head Screw (4 pcs)

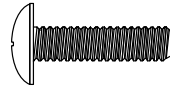

**#74.** M5 x 25m/m\_  
Phillips Head Screw (2 pcs)

## ASSEMBLY TOOLS

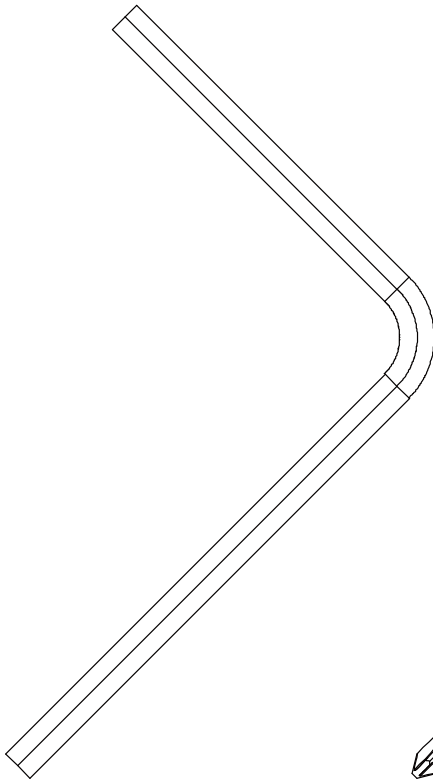

**#132.** M6\_L Allen Wrench

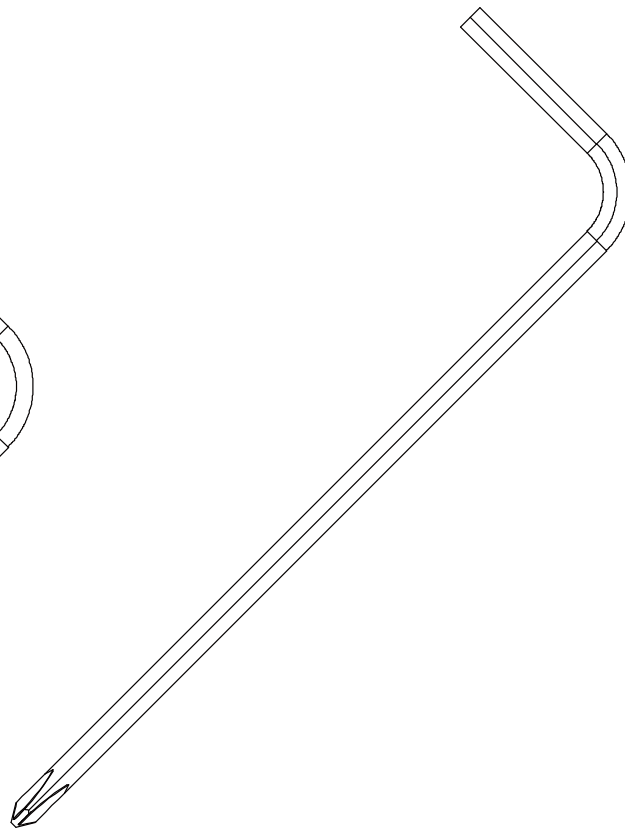

**#131.** Allen Wrench Head Screw Wrench

# F85 ASSEMBLY INSTRUCTIONS

## 1 ASSEMBLY STEP 1

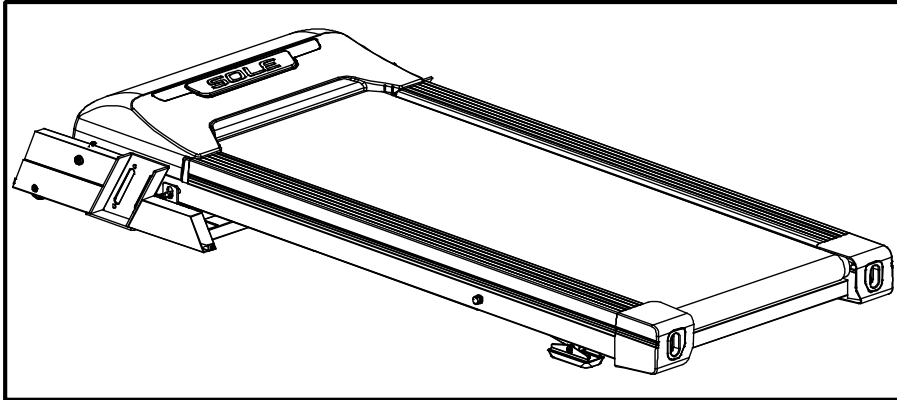

1. Remove the treadmill from the carton and position it aside on a smooth, level floor. The rear should be at least 3' from any wall. Do not remove the Velcro belt until you have removed the plastic wrap and Styrofoam from beneath the unit. **Turning the unit on its side after removing the belt may cause the unit fold up and cause serious injury!**

## 2 ASSEMBLY STEP 2

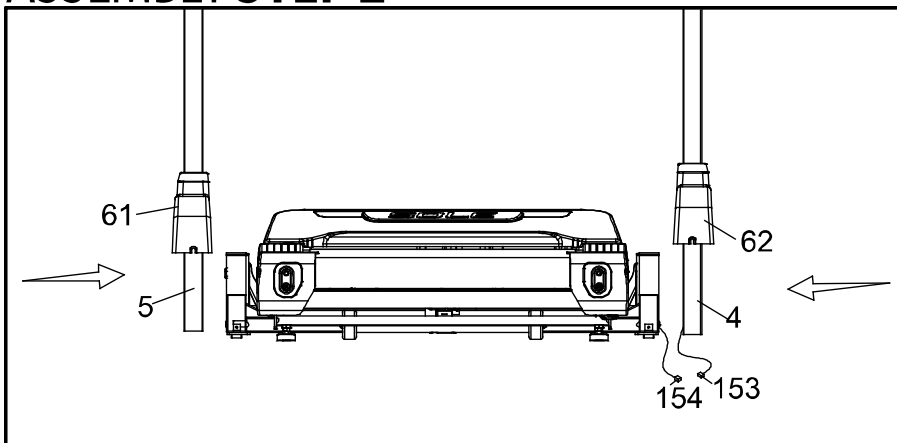

1. Insert Left Upright (5) through Frame Base Cover (L) (61) and insert Right Upright (4) through Frame Base Cover (R) (62) and connect 6P Computer Cable (Middle) (153) with 6P Computer Cable(Lower) (154).

**Before attaching the hardware to Step 3, make sure the cables you just connected don't get pinched in between the steel tubing. If they do, this may cause issues that prevent the treadmill from operating properly.**

# 3 ASSEMBLY STEP 3

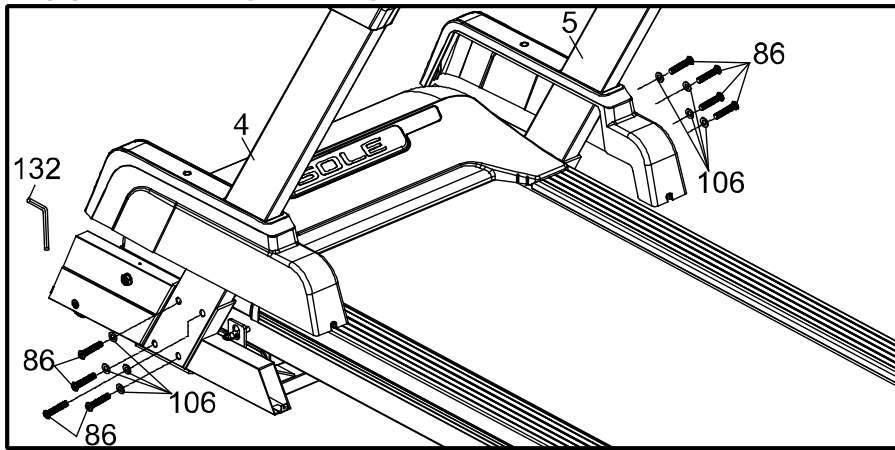

## HARDWARE STEP 3

- #106.  $\varnothing 3/8'' \times \varnothing 19 \times 1.5T$ \_Flat Washer (8 pcs)
- #86.  $3/8'' \times \text{UNC}16 \times 2''$ \_Flat Head Socket Bolt (8 pcs)

1. Insert the Right and Left Uprights (4) and (5) into Frame Base (2) and then use Allen Wrench (132) to tighten 8 pcs of Flat Head Socket Bolt (86) and 8 pcs of Flat Washer (106). **Do not tighten the bolts completely until Step 5 is finished.**

# 4 ASSEMBLY STEP 4

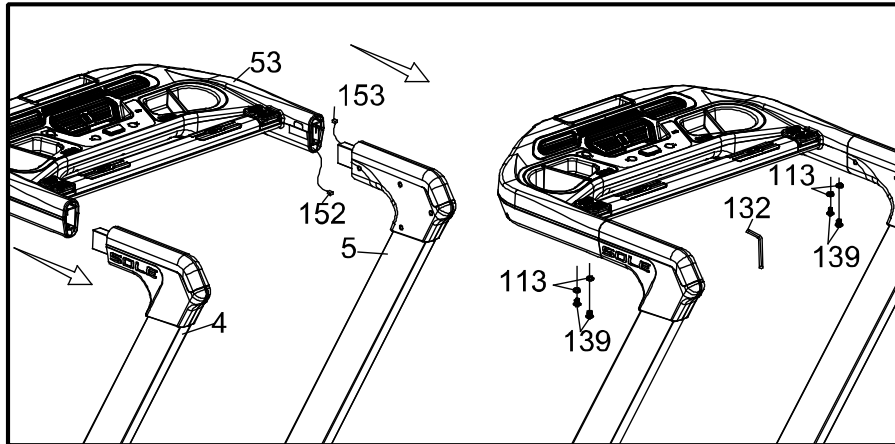

## HARDWARE STEP 4

- #113.  $\varnothing 10 \times 1.5T$ \_Split Washer (4 pcs)
- #139.  $3/8'' \times 1/2''$ \_Button Head Socket Bolt (4 pcs)

1. Connect 6P Computer Cable (Middle) (153) with 6P Computer Cable (Upper) (152) then insert Console Assembly(Bottom) (53) into the Right and Left Uprights (4) and (5) and use M6\_L Allen Wrench (132) to tighten 4 pcs of Button Head Socket Bolt (139) and 4 pcs of Split Washer (113).

**Before attaching the hardware in Step 5, make sure the cables you just connected don't get pinched in between the steel tubing. If they do, this may cause issues that prevent the treadmill from operating properly.**

# 5 ASSEMBLY STEP 5

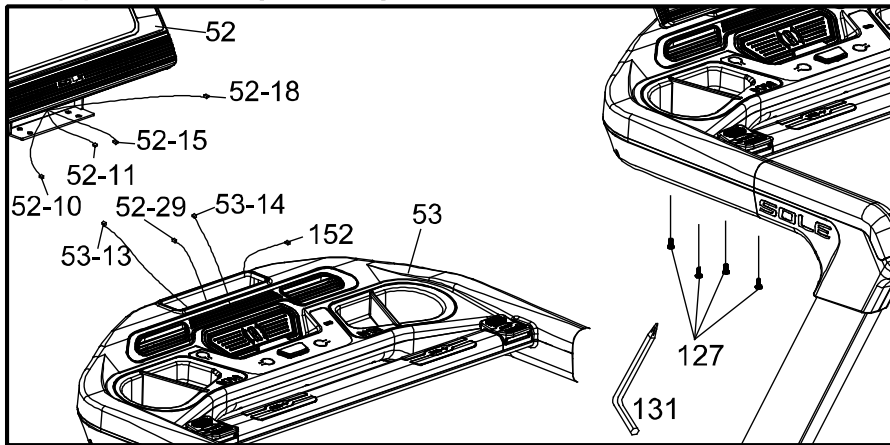

## HARDWARE STEP 5

#127. M5 × 15m/m\_  
Phillips Head Screw  
(4 pcs)

1. Connect 9P Computer Cable (Upper) (**52-10**) with 9P Computer Cable (Lower) (**53-13**), and connect 4P Computer Cable (Upper) (**52-11**) with 4P Computer Cable (Lower) (**53-29**), and connect 7P Computer Cable (Upper) (**52-15**) with 7P Computer Cable (Lower) (**53-14**), and connect 6P Computer Cable (**52-18**) with 6P Computer Cable (Upper) (**152**).
2. Place Console Assembly (Top) (**52**) to Console Assembly(Bottom) (**53**) and use M5\_Allen Wrench Head Screw Wrench (**131**) to tighten 4 pcs of Phillips Head Screw (**127**).

**NOTE:** Please Tighten All Screws After All Components Assembly Complete.

# 6 ASSEMBLY STEP 6

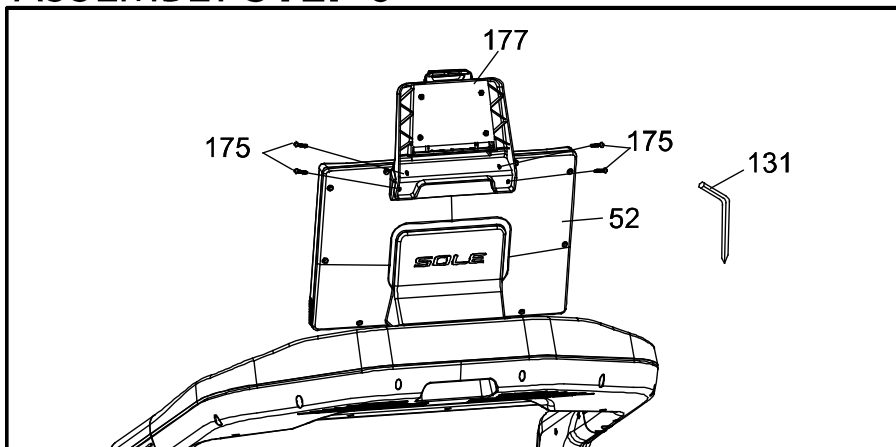

## HARDWARE STEP 6

#175. 3.5 × 16m/m\_  
Sheet Metal Screw  
(4 pcs)

1. Place Tablet Holder (**177**) on Console Assembly(Top) (**52**) and use M5\_Allen Wrench Head Screw Wrench (**131**) to tighten 4 pcs of Sheet Metal Screw (**175**).

# 7 ASSEMBLY STEP 7

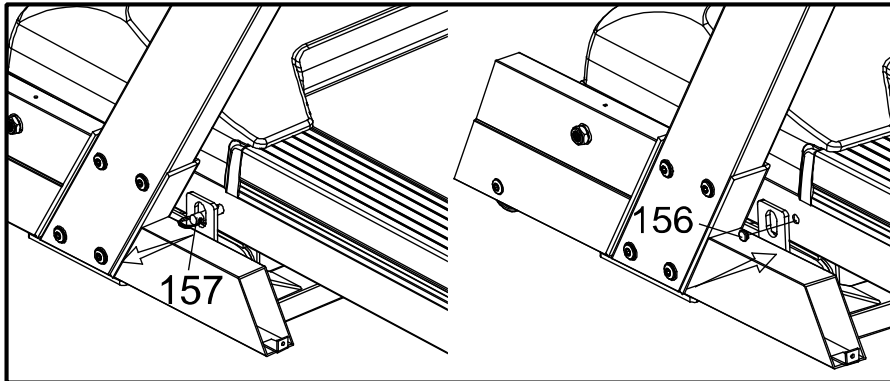

**NOTE:** After the above, please pull the locking pin (157) out and insert the End Cap (156) into the hole.

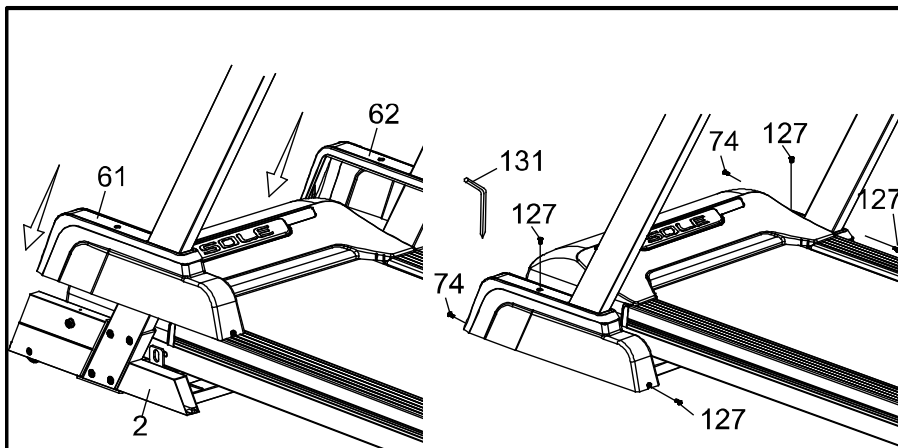

1. Install Frame Base Cover left (61) and right (62) in Frame Base (2) and use M5 Allen Wrench Head Screw Wrench (131) to tighten 4 pcs of Phillips Head Screw (127) and 2 pcs of Phillips Head Screw (74) into Frame Base (2).

## HARDWARE STEP 7

#74. M5 × 25m/m\_ Phillips Head Screw (2 pcs)

#127. M5 × 15m/m\_ Phillips Head Screw (4 pcs)

# FOLDING INSTRUCTIONS

Do not attempt to move the unit unless it is in the folded and locked position. Be sure the power cord is secured to avoid possible damage. Use both handrails to maneuver the unit to the desired position.

## ■ TO FOLD THE TREADMILL

Make certain the treadmill is at minimum incline. Lift the treadmill running deck until it is secured by the locking telescoping tube assembly in center back of base.

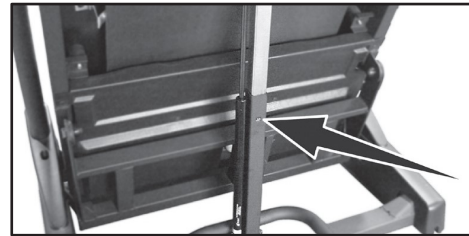

## ■ TO UNFOLD THE TREADMILL

Apply slight forward pressure\* on the treadmill running deck with one hand. Pull down on the unlocking lever and slowly lower the running deck to the floor. The deck will lower unassisted when it reaches about waist high.

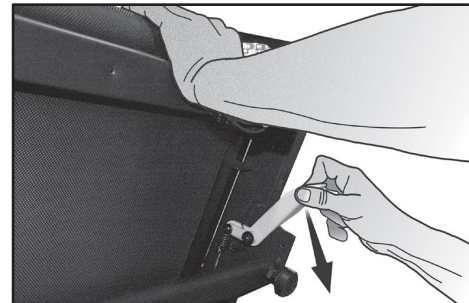

- \*At the rear roller area to relieve pressure on the locking system.

# TRANSPORTATION INSTRUCTIONS

The treadmill is equipped with transport wheels that are engaged when the treadmill is folded. After folding simply roll the treadmill away.

# OPERATION OF YOUR TREADMILL

## GETTING FAMILIAR WITH THE CONTROL PANEL

### F85 CONSOLE



## GETTING STARTED

### F85 CONSOLES

Power the treadmill on by plugging it into an appropriate wall outlet, then turn on the power switch located at the front of the treadmill below the motor hood. Ensure that the **Safety Key** is installed, as the treadmill will not power on without it (*see assembly step 7 for reference*).



### \*\*ATTENTION\*\*

**SLEEP MODE** Your console comes in "Sleep mode" with different features by choice:

**ON** The unit goes energy-saving state after 15 minutes of inactivity.

**OFF** The console will stay lit while the power is on.

**RETAIL** The console will run the demo video after 3 minutes of inactivity.

**On TFT displays**, click "Sleep Mode" under Settings to switch among three features.

# TOUCHSCREEN OPERATION

Use the touchscreen console to select from a variety of preset workout programs and fitness tests, and to enjoy media content of your choice while on the go.

The User Interface (UI) images in the manual reflect the version of software when the product was produced. The software version may be updated occasionally to include new features or repair any bugs when connected to the internet. These updates may change the UI images on the console and may no longer match the manual images.

## Getting Started

Launched for the first time, the console will prompt you to either enter as a guest, or create a new profile. It is recommended to set up your own profile: it allows your machine to remember your physical parameters, favorite programs and templates; you will have your own custom program with an adjustable intensity pattern, and your workout records can be synchronized with the SOLE+ mobile app. Tap + to create a new profile. A maximum of 9 profiles can be created. Each profile can be protected with a passcode.

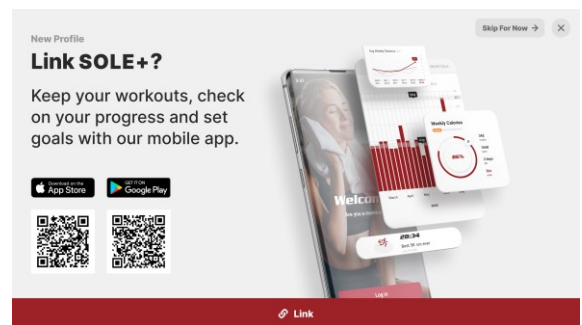
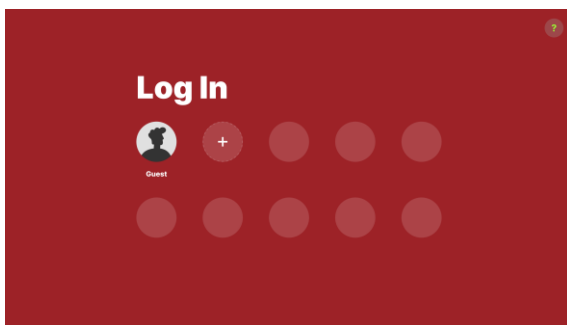

To link a SOLE+ account, scan the QR code on the console screen to download the mobile app first. Once the app is installed and the registration is complete, press "Link" on the bottom of the console screen, then open the QR code scanning camera in your SOLE+ app, and scan the QR code once again to link your local profile with the SOLE+ account. Please keep in mind that your console profile cannot be linked to multiple SOLE+ accounts at the same time. If you skip this step, you can access it again later in Profile settings.

## Home Screen

**The main screen** of the Training section displays an overview of your activity, and offers shortcuts to the most frequently used training modes: an immediate Start, a manually controlled timed workout ("Timer"), and up to 6 programs that you have marked as your favorites are arranged on this page for your quick access.

If in the Guest mode, you can set your age and weight here; it will help the machine calculate your workout summary more accurately.

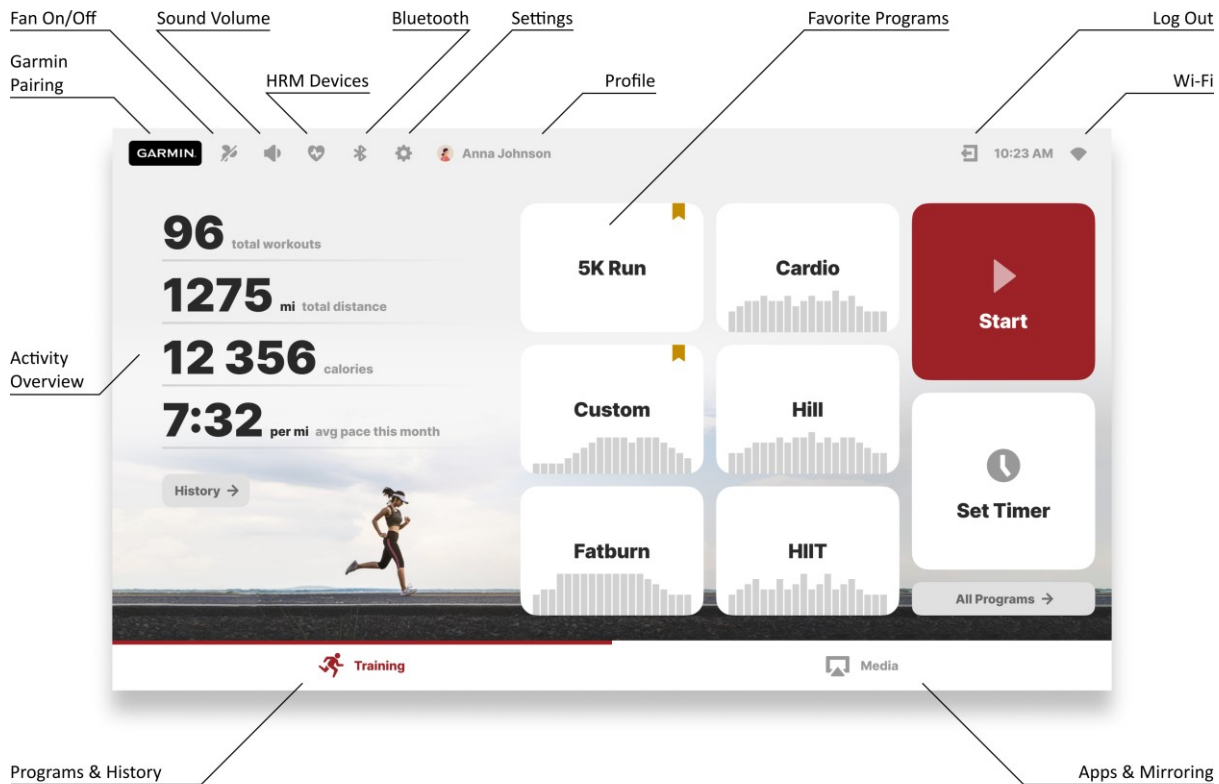

## Workout Programs

To access all available categories of programs, press “All Programs” on the Home screen. Once inside, switch between categories using the tabs on the top of the screen: Programs, Fitness Tests, Templates and Favorites.

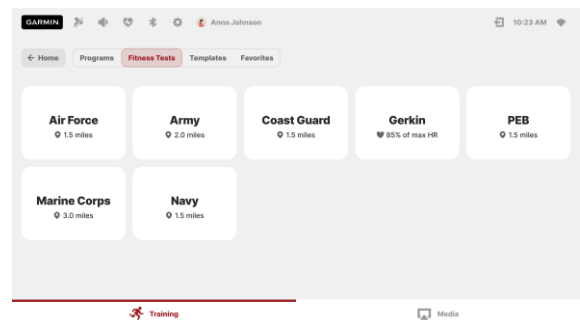
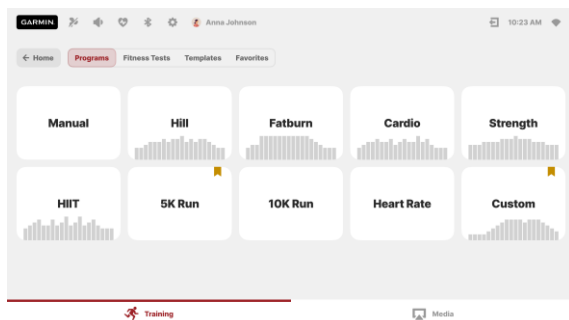

Tap on any of the program cards to open a Program Setup page, where you can learn more about the program, set properties of your workout, or keep browsing by pressing on the arrow buttons in the upper top right corner of the screen. To adjust workout parameters, you can drag the ruler, tap on the + and – buttons, or tap on the number to open a numpad and input the value directly.

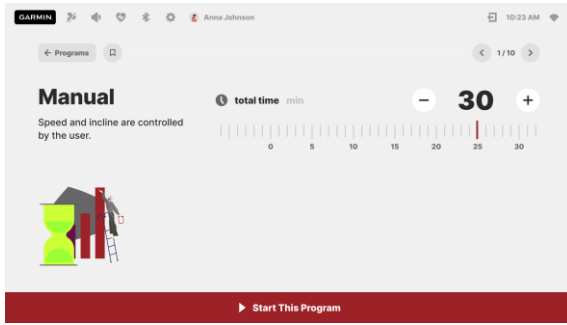

**Manual (Timer)** program is a timed workout with speed and incline controlled manually at any time during the run.

**Hill, Fatburn, Cardio, Strength** and **HIIT** follow preset speed and incline changing patterns. The Total Time and Max Speed settings define the duration and overall intensity of your workout.

The speed and incline levels for each segment of the programs are shown in the chart below. Speed values represent a percentage of the max speed that was set before start. For instance, if the max speed was set to 10.0 mph, and the value in the chart indicates 20, it means that this segment's speed will be 2.0 mph. If the value in the chart indicates 100, this segment's speed will be equal to the max speed you have set before the workout. Incline values are absolute.

Program		Warm up		1	2	3	4	5	6	7	8	9	10	11	12	13	14	15	16	17	18	19	20	Cool down			
Hill	Speed	40	40	50	66	66	66	66	66	88	88	88	100	100	100	100	100	88	88	88	100	88	66	66	50	40	40
	Incline	0	0	0	0	0	4	8	8	-4	7	7	-5	-5	7	8	9	-4	-4	-5	5	-3	0	0	0	0	0
Fatburn	Speed	40	40	50	75	75	88	88	100	100	100	100	100	100	100	100	100	100	100	88	88	75	75	50	40	40	
	Incline	0	0	0	0	0	4	6	0	0	0	0	6	6	-4	-4	6	0	0	0	0	-3	0	0	0	0	0
Cardio	Speed	40	40	50	66	66	66	75	75	88	88	75	75	88	66	88	75	100	100	88	75	75	66	66	50	40	40
	Incline	0	0	0	0	0	4	4	4	-3	4	4	-2	-2	3	3	3	-2	-2	3	0	0	0	0	0	0	0
Strength	Speed	40	40	50	66	66	66	75	75	75	75	88	88	100	100	100	88	88	88	100	88	75	66	66	50	40	40
	Incline	0	0	0	0	0	4	6	8	10	10	-3	-5	-5	8	8	10	-4	-4	6	8	-5	0	0	0	0	0
HIIT	Speed	40	40	50	75	75	100	50	100	50	100	50	100	50	100	50	100	50	100	50	100	50	100	100	50	40	40
	Incline	0	0	0	0	0	4	0	4	0	4	0	4	0	4	0	4	0	4	0	4	0	0	0	0	0	0

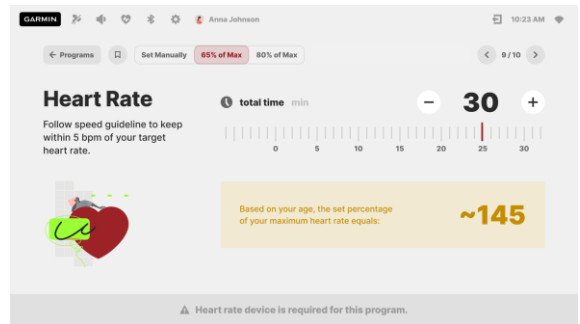
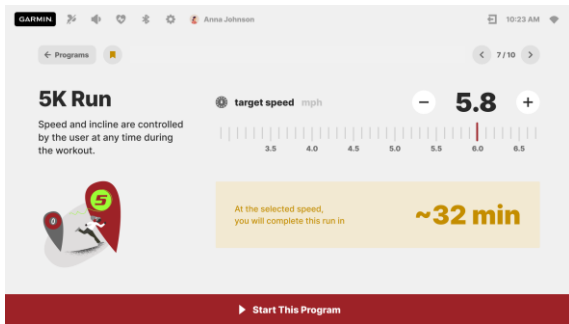

**5K Run, 10K Run** programs automatically set a target distance for your workout (5 km and 10 km, respectively). On the program setup page, the console will show the estimated total time for this run based on the selected target speed. Program ends when the target distance is reached.

**Heart Rate** program uses incline to control your heart rate. The incline gradually increases until you reach your target heart rate, then adjusts automatically to keep you within 5 bpm of your goal. A heart rate monitor is required for this program.

On the program setup page, you can either set the target bpm directly or select 60% or 80% of your age-predicted maximum heart rate, allowing the machine to calculate your target automatically. Choosing the second option, make sure you have let the machine know how old you are, otherwise the calculations will be based on the default values. The program is finished when the time is up, or if your heart rate is 20% higher than the target.

**Custom** is a program with fully customizable speed and incline patterns. On the program setup page, press “Add Pattern” to enter edit mode. Connect dots to map your load throughout the program, from easiest on the bottom to hardest on the top. Each segment’s duration depends on the selected total time — you can set it right before start.

Speed values are relative, and maximum can be changed before each workout; all the segments will be adjusted proportionally. Elevation values are absolute and vary from -6 to +15. Elevation pattern is optional.

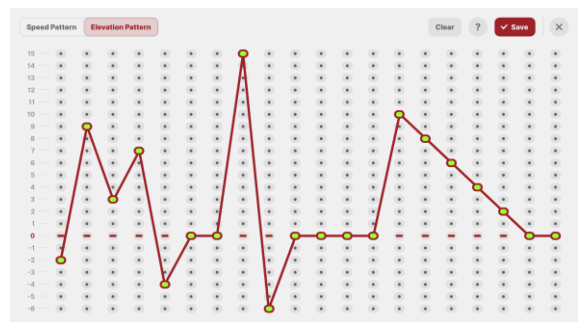
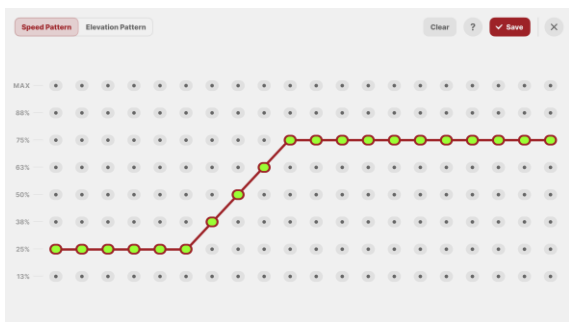

**Templates** are preset programs with a preserved set of parameters. Programs can be saved as templates upon completion, or you can create one from scratch in the Templates tab: tap on the “New Template” button, choose your base program, then save it with adjusted properties. A maximum of 12 template programs can be stored. To remove the unwanted templates, press “Edit Templates” in the Templates tab.

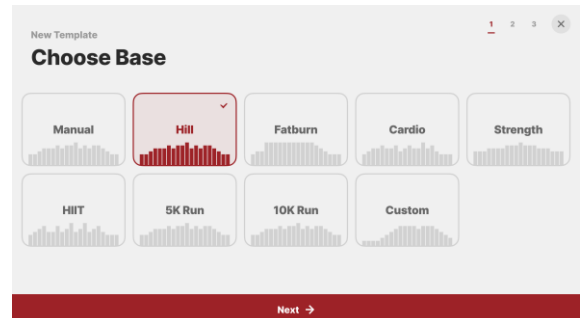
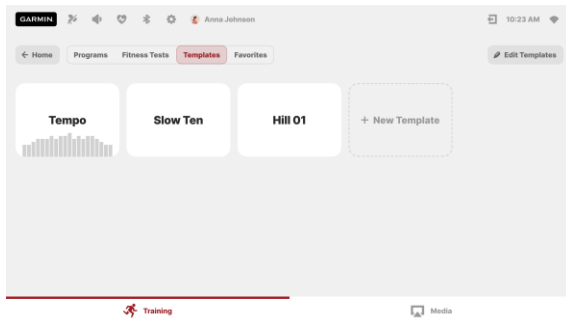

A program can be labeled as a **Favorite**. Up to 6 favorite programs will appear right on the Home screen, so you can access them easier. To “like” a program, open the program setup page and tap on the “ribbon” icon in the upper left corner of the screen. You can find all of the labeled programs under the Favorites tab: to remove the label, press “Edit Favorites”, or go to the program setup page directly and un-tap the “ribbon” icon.

Once you have decided on the program, press the “Start This Program” button on the screen, or the physical “START” key on the machine to begin your workout.

## Fitness Tests

Choose from 7 options under the Fitness Tests tab. Tap on the test card to open the test setup page. Please make sure that the physical parameters displayed on this page are correct: this data may affect the course of the test and its results; if the data is not accurate, press “Edit Parameters” to adjust the numbers.

Before the test,

- make sure you are in good health; check with your physician before performing any exercise if you are over the age of 35 or have any pre-existing health conditions;
- make sure you have warmed up and stretched before taking the test;
- do not take in caffeine before the test.

**Gerkin Protocol** is a sub maximal VO<sub>2</sub> (volume of oxygen) test, that increases speed and incline alternately until you reach 85% of your max heart rate (a heart rate monitor is required for this test). The time it takes for you to reach 85% determines the test score (VO<sub>2</sub> Max). The test starts with a 3-minute warm-up at a lower speed.

**Air Force, Army, Navy, Coast Guard, PEB** and **Marine Corps** are US military tests that measure the time required for you to cover a certain distance. The speed is controlled manually.

## History

To see your latest workout records, press “History” on the main screen of the Training section. Up to 10 records can be stored locally on the console, but you can access your full workout history if you link your profile to the SOLE+ mobile app. Tap on the record preview to see the full summary. Each user can only see his or her workouts.

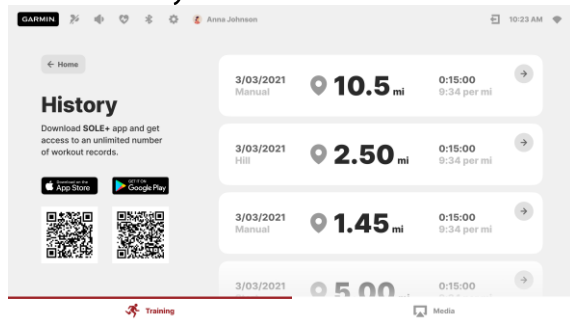

## Media

Tap on the right tab of the bottom panel to access the Media section. Choose from a variety of pre-installed third party **Apps**, or use the **Mirroring** function to cast the content from your smartphone directly to the console screen. For detailed instructions, press the ? icon.

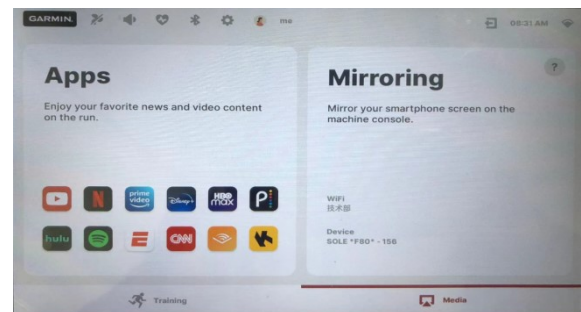

Once the content is on, use the floating panel for navigation and operating full screen mode. Touch the panel’s top edge and drag the panel around the screen to find the perfect place for it, where it will not prevent you from interacting with the content. Press Hide Panels to enter the full screen mode without stats on the top and tabs on the bottom, and Show Panels to bring them back. Use the arrow button on the right side of the panel to hide & show the text labels: it allows to further minimize the panel’s size. Press “Apps” to go back to the content sources selection.

## Workout Mode

Once the workout has started, after the short countdown the console will appear in its workout mode. Warm-up and cool down phases may be skipped by pressing "Skip".

During the workout, switch between **Stats**, **Charts** and **Track** views of the Training section, or go to Media section to enjoy your favorite media content. In the Stats view, you can select parameters you would like to display by tapping on the number.

Please use physical keys to adjust speed and incline. Press the physical "STOP" key to pause the workout. Here, you can get back to running, start a cool down, or end your workout and see the summary. After 5 minutes of inactivity in the Pause mode, the workout will end automatically.

The actual machine operation may differ slightly from the description in the manual.

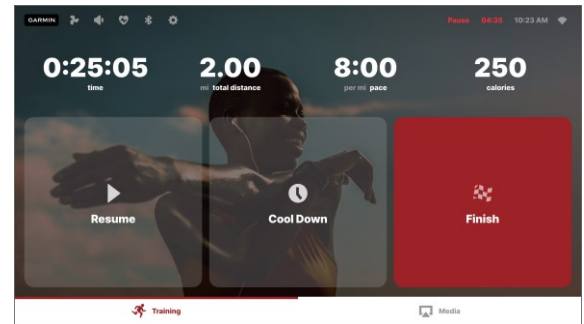
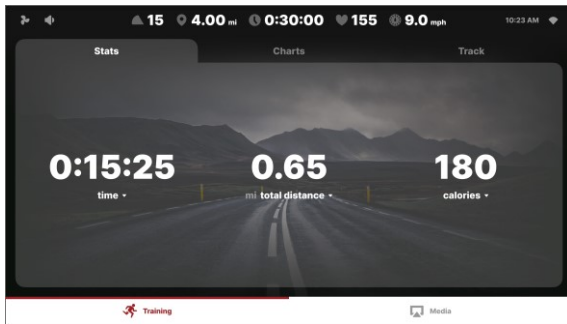

## New Sole+ App to be used in conjunction with select Apple & Android devices!

In order to help you achieve your exercise goals, your new exercise machine comes equipped with a Bluetooth® transceiver that will allow it to interact with selected phones or tablet computers via the Sole + App.

Just download the free Sole + App from the Apple Store or Google Play, and then follow the instructions in the App to sync with your exercise machine.

You can press the "DISPLAY" button from the APP to view the display of the current workout data. When your exercise is complete pressed in the APP "END & SAVE WORKOUT" to store the workout data.

The Sole + App also allows you to sync your workout data with one of many fitness cloud sites we support: Apple Health, Google Fit, Strava, MapMyFitness or Fitbit, with more to come.

### Syncing the App with your exercise machine:

1. Download the App by scanning the QR code on the right.
2. Open the App on your device (phone or tablet) and make sure Bluetooth® is enabled on your device(phone or tablet).
3. In the App click the Bluetooth icon to search for your Sole + equipment (shown right).

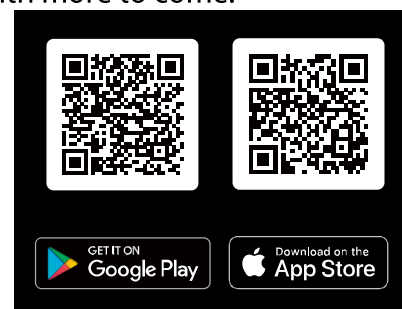

4. Under the Bluetooth scan result list, select the machine for connect. When the App and equipment are synced, the Bluetooth® icon on the equipment's console display will light up. Click "DISPLAY", you may now start using your Sole + App.
5. When your exercise is complete pressed in the APP "END & SAVE WORKOUT" to store the workout data, and you will be prompted to sync your data with each available fitness cloud site. Please note you will have to download the applicable compatible fitness App, such as Apple Health, Google Fit, Strava, MapMyFitness or Fitbit, etc, in order for the icon to be active and available.  
**Note:** Your device will need to be running on a minimum operating system of IOS 13.1 or Android 8.0 for the Sole + App to operate properly.

The exercise equipment can also play music wirelessly via Bluetooth. Turn on your mobile phone or tablet's Bluetooth function. Search for the name "Bt-speaker" in your device's Bluetooth menu. Tap to connect. Now your device can transmit music to the exercise equipment.

The exercise equipment's Bluetooth device (BLE 5.0) can also be connected to the Bluetooth wireless heart rate chest strap transmitter (BLE 5.0). The chest strap transmitter can receive signals even when the App is already in use. You can wear the Bluetooth wireless heart rate chest strap first then commence connection. While in connection, the console will show heart rate value via Bluetooth.



The icon lights up when connecting to a Bluetooth heart rate chest strap successfully and the heart rate will then be displayed. The icon will be off if the Bluetooth heart rate chest strap is disconnected.

## Wireless Charging

Wireless Charging function:

Charge your personal device during your workout by placing it inside the wireless charging box/area properly.

NOTE :

- \*\* Your device must be set in the landscape orientation for best result.
- \*\* Your device "charging" icon will indicate it is charging.
- \*\*\* It provides up to 10 watts of power for many cell phones supporting wireless charging function.



# HEART RATE PROGRAMS

## Before we get started, a word about Heart Rate:

The old motto, “no pain, no gain”, is a myth that has been overpowered by the benefits of exercising comfortably. A great deal of this success has been promoted by the use of heart rate monitors. With the proper use of a heart rate monitor, many people find that their usual choice of exercise intensity was either too high or too low and exercise is much more enjoyable by maintaining their heart rate in the desired benefit range.

To determine the benefit range in which you wish to train, you must first determine your Maximum Heart Rate. This can be accomplished by using the following formula: 220 minus your age. This will give you the Maximum Heart Rate (MHR) for someone of your age. To determine the effective heart rate range for specific goals you simply calculate a percentage your MHR. Your Heart rate training zone is 50% to 90% of your maximum heart rate. 60% of your MHR is the zone that burns fat while 80% is for strengthening the cardio vascular system. This 60% to 80% is the zone to stay in for maximum benefit.

For someone who is 40 years old their target heart rate zone is calculated:

$$220 - 40 = 180 \text{ (maximum heart rate)}$$

$$180 \times 0.6 = 108 \text{ beats per minute}$$

(60% of maximum)

$$180 \times 0.8 = 144 \text{ beats per minute}$$

(80% of maximum)

So for a 40 year old the training zone would be 108 to 144 beats per minute.

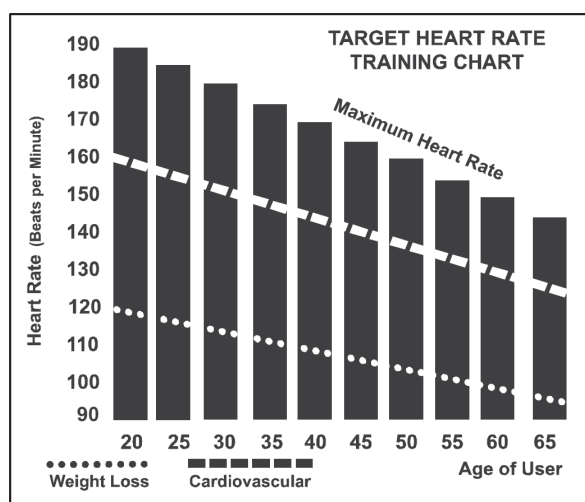

If you enter your age during programming the console will perform this calculation automatically. Entering your age is used for the Heart Rate programs. After calculating your MHR you can decide upon which goal you would like to pursue.

The two most popular reasons for, or goals, of exercise are cardiovascular fitness (training for the heart and lungs) and weight control. The black columns on the chart above represent the MHR for a person whose age is listed at the bottom of each column. The training heart rate, for either cardiovascular fitness or weight loss, is represented by two different lines that cut diagonally through the chart. A definition of the lines' goal is in the bottom left-hand corner of the chart. If your goal is cardiovascular fitness or if it is weight loss, it can be achieved by training at 80% or 60%, respectively, of your MHR on a schedule approved by your physician. Consult your physician before participating in any exercise program.

## **RATE OF PERCEIVED EXERTION**

Heart rate is important but listening to your body also has a lot of advantages. There are more variables involved in how hard you should workout than just heart rate. Your stress level, physical health, emotional health, temperature, humidity, the time of day, the last time you ate and what you ate, all contribute to the intensity at which you should workout. If you listen to your body, it will tell you all of these things.

The rate of perceived exertion (RPE), also know as the Borg scale, was developed by Swedish physiologist G.A.V. Borg. This scale rates exercise intensity from 6 to 20 depending upon how you feel or the perception of your effort.

The scale is as follows:

### Rating Perception of Effort

- 6 Minimal
- 7 Very,very light
- 8 Very,very light +
- 9 Very light
- 10 Very light +
- 11 Fairly light
- 12 Comfortable
- 13 Somewhat hard
- 14 Somewhat hard +
- 15 Hard
- 16 Hard +
- 17 Very hard
- 18 Very hard +
- 19 Very,very hard
- 20 Maximal

You can get an approximate heart rate level for each rating by simply adding a zero to each rating. For example a rating of 12 will result in an approximate heart rate of 120 beats per minute. Your RPE will vary depending up the factors discussed earlier. That is the major benefit of this type of training. If your body is strong and rested, you will feel strong and your pace will feel easier. When your body is in this condition, you are able to train harder and the RPE will support this. If you are feeling tired and sluggish, it is because your body needs a break. In this condition, your pace will feel harder. Again, this will show up in your RPE and you will train at the proper level for that day.

# USING HEART RATE TRANSMITTER (OPTIONAL)

If you purchase a wireless chest strap transmitter from Sole, here are the instructions on how to wear it:

1. Attach the transmitter to the elastic strap using the locking parts.
2. Adjust the strap as tightly as possible while ensuring that the strap is not too tight to remain comfortable.
3. Position the transmitter with the SOLE logo in the middle of your body, facing away from your chest. Some people may have to position the transmitter slightly left of the center of their chest. Attach the end of the elastic strap by inserting the round end. Using the locking parts, secure the transmitter and strap around your chest.
4. Position the transmitter immediately below the pectoral muscles.
5. Sweat is the best conductor for measuring minute heartbeat electrical signals. However, you can use plain water to pre-wet the electrodes. The electrodes are the two ribbed oval areas on the reverse side of the belt and both sides of the transmitter. We also recommend wearing the transmitter strap a few minutes before your workout to warm it up. Because of body chemistry, some users have a more difficult time achieving a strong, steady signal initially. Warming up with the transmitter will help decrease this problem. As noted, wearing clothing over the chest strap transmitter will not affect performance.
6. Your workout must be within rangelange to achieve a strong and steady signal. The range length may vary, so stay close enough to the console to maintain strong and reliable readings. Wearing the transmitter immediately against bare skin assures you of proper operation. If you wish, you may wear the transmitter over a shirt. To do so, moisten the areas of the shirt where the electrodes will rest.

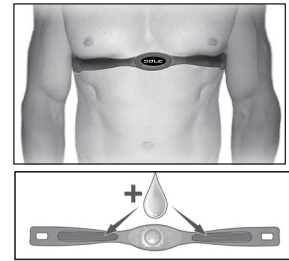

**Note:** The transmitter automatically activates when it detects activity from the user's heart and automatically deactivates when it does not receive any activity. Although the transmitter is water resistant, moisture can create false signals, so you should take precautions to dry the transmitter after use to prolong battery life completely. The estimated transmitter battery life is 2500 hours. The replacement battery is a Panasonic CR2032.

## ERRATIC OPERATION

**Caution!** Do not use this treadmill for Heart Rate unless a steady, solid Actual Heart Rate value is being displayed. High, wild, random numbers being displayed indicate a problem.

Areas to look for interference which may cause erratic heart rate:

1. Microwave ovens, TV's, small appliances, etc.
2. Fluorescent lights.
3. Some household security systems.
4. Perimeter fence for a pet.
5. Some people have problems with the transmitter picking up a signal from their skin. If you have problems try wearing the transmitter upside down. Normally the transmitter will be oriented so the SOLE logo is right side up.
6. The antenna that picks up your heart rate is very sensitive. If there is an outside noise source, turning the whole machine 90 degrees may de-tune the interference.
7. Loose treadmill console or bolts in the upright tube.
8. Another Individual wearing a transmitter within 3' of your machine's console.

If you continue to experience problems contact your dealer.

To check if your Garmin device can be used for heart rate transmission, please refer to the list of supported devices provided on [www.soletreadmills.com](http://www.soletreadmills.com)

**WARNING! - DO NOT USE THE HEART RATE PROGRAM IF YOUR HEART RATE IS NOT REGISTERING PROPERLY ON THE TREADMILL'S DISPLAY!**

# GENERAL MAINTENANCE

## BELT & DECK

Your treadmill uses a very high-efficient low-friction deck. Performance is maximized when the deck is kept as clean as possible. Use a soft, damp cloth, or paper towel, wipe the edge of the belt and the area between the belt edge and the frame. Also reach as far as practical directly under the belt edge. This should be done once a month to extend belt and bed life. A mild soap and water solution along with a nylon scrub brush will clean the top of the textured belt. **Allow to dry before using.**

## BELT DUST

This occurs during normal break-in or until the belt stabilizes. Sometimes the black dust from the belt will appear on the floor behind the treadmill, this is normal.

## GENERAL CLEANING (Use the chart on Pg. 5 to record your maintenance)

Dirt, dust, and hair can block air inlets and accumulate on the running belt. Please vacuum underneath your treadmill on a monthly basis to prevent excess build-up of dirt that can get sucked up and get into the inner workings under the motor cover. Every other month, you should remove the motor cover and carefully vacuum out dirt and hair that may accumulate. **UNPLUG THE POWER CORD BEFORE THIS TASK.**

# BELT ADJUSTMENTS

Tread-belt Tension Adjustment - Belt tension is not critical for most users. It is very important though for joggers and runners in order to provide a smooth, steady running surface. Adjustment must be made from the rear roller with the M6 L Allen wrench (**132**) provided in the parts package. The adjustment bolts are located at the end of the step rails as shown in the diagram below. **Note:** *Adjustment is through small hole in end cap.*

Tighten the rear roller only enough to prevent slippage at the front roller. Turn the tread-belt tension adjusting bolts 1/4 turn each and inspect for proper tension by walking on the belt and making sure it is not slipping or hesitating with each step. When an adjustment is made to the belt tension, you must be sure to turn the bolts on both sides evenly or the belt could start tracking to one side instead of running in the middle of the deck.

**DO NOT OVERTIGHTEN** – Over tightening will cause belt damage and premature bearing failure. If you tighten the belt a lot and it still slips, the problem could actually be the drive belt - located under the motor cover - that connects the motor to the front roller. If that belt is loose it feels similar to the walking belt being loose. Tightening the motor belt should be done by a trained service person.

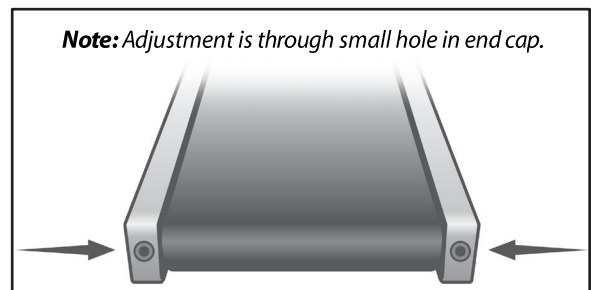

# TREAD-BELT TRACKING ADJUSTMENT

The treadmill is designed so that the tread-belt remains reasonably centered while in use. It is normal for some belts to drift near one side while in use, depending on a user's gait and if they favor one leg. But if during use the belt continues to move toward one side, adjustments are necessary.

## SETTING TREAD-BELT TRACKING

A 6 mm Allen wrench (132) is provided for this adjustment. Make tracking adjustments on the left side bolt. Set belt speed at 3 mph. Be aware that a small adjustment can make a dramatic difference which may not be apparent right away. If the belt is **too close to the left side**, then turn the bolt only a 1/4 turn to the right (clockwise) and wait a few minutes for the belt to adjust itself.

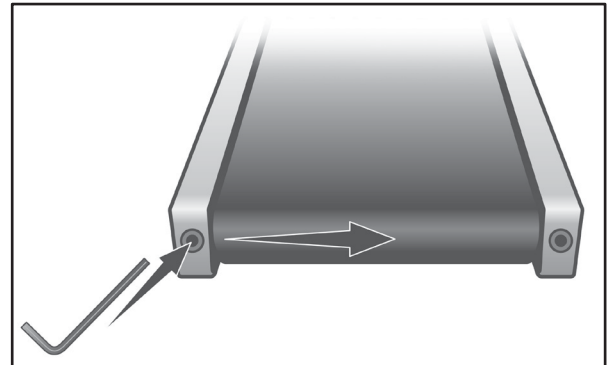

Continue to make 1/4 turns until the belt stabilizes in the center of the running deck.

If the belt is **too close to the right side**, turn the bolt counter-clockwise. The belt may require periodic tracking adjustment depending on use and walking/running characteristics. Some users may affect tracking differently. Expect to make adjustments as required to center the tread-belt. Adjustments will become less of a maintenance concern as the belt is used. Proper belt tracking is an owner responsibility common with all treadmills.

## ATTENTION:

**DAMAGE TO THE RUNNING BELT RESULTING FROM IMPROPER TRACKING / TENSION ADJUSTMENTS IS NOT COVERED UNDER THE SOLE WARRANTY.**

## TREADMILL BELT

The walking belt on your new Sole treadmill is made of the highest quality materials designed to last even under punishing conditions. When a treadmill belt is brand new, and has been in the package for a few months before use, a common occurrence can happen; the area of the belt that wraps around the rollers will take on the shape of the roller. Upon starting the treadmill this shape in the belt causes a thumping sound each time the belt moves past the rollers. Once the treadmill has been used for a few workouts, the belt wears in and the thumping sound goes away. This noise is normal on new higher end belts so there is no need to contact service; the new belt just requires a wear in period. Thank you for choosing Sole and enjoy your new treadmill.

# BELT/DECK LUBRICATION

First, you want to clean between the belt and deck to remove any debris that may be trapped. Use a clean, non-fraying rag, t-shirt, or light towel. Halfway between the end of the treadmill and motor cover, shove the garment under the belt until you can grasp it on both sides of the belt. Drag the garment the length of the entire belt 1-2 times. Remove the garment.

Do not lubricate with anything other than Sole Fitness approved lubricant. 100% Food grade Silicone lubricant for treadmills. (DO NOT USE SILICONE CAULKING FOR BATHROOM AND KITCHEN PROJECTS OR A LUBRICANT THAT HAS A SPRAY/FOAM BASE)

Your treadmill comes with one tube of "Lube" and extra tubes can be ordered directly from Sole Fitness or your authorized Sole Fitness dealer. You may also use a Lube-n-Walk kit that can be purchased through both aforementioned sellers. You need to use 2-3 ounces of lubrication each application.

Keeping the deck lubricated at the recommended intervals ensures the longest life possible for your treadmill. If the lubricant dries out, the friction between the belt and deck rises and places undue stress on the drive motor, drive belt and electronic motor control board, which could result in catastrophic failure of these expensive components. Failure to lubricate the deck at regular intervals may void the warranty.

The belt & deck come pre-lubricated and subsequent lubrication should be performed every 90 hours of use, or every 90 days, regardless of usage as it can dry out, or if you notice that the deck is dry. It is recommended that you reach between the belt and deck to verify there is lubrication present, every other month. If you check and there isn't any lubrication present, follow the procedure below even though the "Lube" indicator isn't lit on the console. Otherwise, lubricate when the console's lubrication reminder lights after 90 hours of use. Use the following procedure to apply the silicone lubricant:

1. Turn the power switch off and unplug the power cord from the wall outlet.
2. Measure 18" from the edge of the motor cover; kneel down and reach under the belt approximately 4- 6" from one edge. Squirt a line of lubricant about 1/8" wide x 15" long in an "S" pattern perpendicular to the motor cover.
3. Repeat the process on the opposite side.
4. Plug the electrical cord back into the outlet and turn the power switch on.
5. Walk on the belt at a moderate speed for five minutes to evenly distribute the silicone lube.

# SERVICE CHECKLIST - DIAGNOSIS GUIDE

Before contacting your dealer for aid, please review the following information. It may save you both time and expense. This list includes common problems that may not be covered under the treadmill's warranty.

PROBLEM	SOLUTION/CAUSE
<b>Display does not light</b>	<ol style="list-style-type: none"> <li>1. Tether cord not in position.</li> <li>2. Circuit breaker on front grill tripped. Push circuit breaker in until it locks.</li> <li>3. Plug is disconnected. Make sure plug is firmly pushed into AC household wall outlet.</li> <li>4. Household circuit breaker may be tripped.</li> <li>5. Treadmill defect. Contact your SOLE dealer.</li> </ol>
<b>Tread-belt does not stay centered Treadmill belt hesitates when walked/run on</b>	<p>The user may be walking while favoring or putting more weight on either the left or right foot. If this walking pattern is natural, track the belt slightly off-center to the side opposite from the belt movement. See <b>General Maintenance</b> section on <b>Tread-belt Tension</b>. Adjust as necessary.</p>
<b>Motor is not responsive after pressing Start</b>	<ol style="list-style-type: none"> <li>1. If the belt moves, but stops after a short time and the display shows "E1", run calibration.</li> <li>2. If you press <b>Start</b> and the belt never moves, then the display shows "E1", contact service.</li> </ol>
<b>Treadmill will only achieve approximately 7 mph but shows higher speed on display</b>	<p>This indicates motor should be receiving power to operate. Low AC voltage to treadmill. Do not use an extension cord. If an extension cord is required it should be as short as possible and heavy duty 16 gauge minimum. Low household voltage. Contact an electrician or your SOLE dealer. A minimum of 120 volt AC current is required.</p>
<b>Tread-belt stops quickly/suddenly when tether cord is pulled</b>	<p>High belt/deck friction. See <b>General Maintenance</b> section on lubrication.</p>
<b>Treadmill trips on board 15 amp circuit</b>	<p>High belt/deck friction. See <b>General Maintenance</b></p>
<b>Computer shuts off when console is touched (on a cold day) while walking/running</b>	<p>Treadmill may not be grounded. Static electricity is "crashing" the computer. Refer to <b>Grounding Instructions</b> on page 3.</p>
<b>House circuit breaker trips, but not the treadmill circuit breaker</b>	<p>Check that the treadmill is the only appliance in the circuit. See "Important Electrical Information" in the front of this manual for more details.</p>

# ERROR MESSAGES FOR DIGITAL- CONTROL SYSTEM TREADMILLS

ERROR	MEANING	POSSIBLE CAUSE	
Console showing E1	No motor output signal	1. Does motor run after "Start" button is pressed?	OK <input type="checkbox"/> NG <input type="checkbox"/>
		2. Connector could be loose for the cable connecting between controller and speed sensor.	OK <input type="checkbox"/> NG <input type="checkbox"/>
		3. Check if speed sensor is defective.	OK <input type="checkbox"/> NG <input type="checkbox"/>
		4. Check if the cable connecting the console and controller is connected properly.	OK <input type="checkbox"/> NG <input type="checkbox"/>
Console showing E2	Over current protection. Treadmill over loaded, controller protection is activated.	1. Check and make sure of proper walking belt alignment. Make sure of periodic lubrication to minimize belt resistance.	OK <input type="checkbox"/> NG <input type="checkbox"/>
		2. Any bearing damage?	OK <input type="checkbox"/> NG <input type="checkbox"/>
		3. Motor overheated?	OK <input type="checkbox"/> NG <input type="checkbox"/>
Console showing E3	Incline Error	1. Is the cable between incline motor and controller connected correctly and properly?	OK <input type="checkbox"/> NG <input type="checkbox"/>
		2. Check if incline mechanism being stock or defective?	
		3. Is VR connected properly or with inter-mittance?	
Console showing E4	Abnormal motor voltage	Motor is not connected properly or even not connected to the controller.	OK <input type="checkbox"/> NG <input type="checkbox"/>
Console showing E5	Communication disconnected between the console and the controller or communication error.	Check and make sure of proper connection between the console and the controller.	OK <input type="checkbox"/> NG <input type="checkbox"/>
Console showing E6	Control board failure	Controller component failure (e.g. IGBT).	<input type="checkbox"/> Change controller
Console showing E7	Abnormal external voltage	Check and make sure of proper voltage input for the treadmill.	OK <input type="checkbox"/> NG <input type="checkbox"/>

# MANUFACTURER'S LIMITED WARRANTY

## TREADMILL WARRANTY

**Effective February 1, 2023**

SOLE warrants all its treadmills' parts, for a period of time listed below, from the date of retail sale, as determined by sale receipt, or in the absence of a receipt eighteen (18) months from the original factory shipping date. SOLE's responsibilities include providing new or remanufactured parts, at SOLE's option, and technical support to our independent dealers and servicing organizations. In the absence of a dealer or service organization, these warranties will be administered by SOLE directly to a consumer. The warranty period applies to the following components:

Frame Weldments	Lifetime
Drive Motor	Lifetime
Deck	3 years
All Other Components	3 years
Labor	1 Year
Cosmetic Items *	90 Days

\*Cosmetic items including, but not limited to the following: grips, console overlays, and labels/decals.

### NORMAL RESPONSIBILITIES OF THE CONSUMER

This warranty applies only to products in ordinary household use, and the consumer is responsible for the items listed below:

1. The warranty registration card must be completed and returned to the address listed on the card within 10 days of the original purchase to validate the manufacturer's limited warranty or, if outside of the 10 day period, the warranty can be registered if you have proof of purchase (i.e. receipt, bank statement, credit card statement, or email order confirmation).
2. Proper use of the treadmill in accordance with the instructions provided in this manual, including general maintenance (i.e. belt tracking, belt tension, vacuuming under motor cover, and lubrication. See all components under General Maintenance section).
3. Proper installation in accordance with instructions provided with the treadmill and with all local electric codes.
4. Proper connection to a grounded power supply of sufficient voltage, replacement of blown fuses, repair of loose connections or defects in house wiring.
5. Expenses for making the treadmill accessible for servicing, including any item that was not part of the treadmill at the time it was shipped from the factory.
6. Damages to the treadmill finish during shipping, installation or following installation.
7. Routine maintenance of this unit as specified in this manual. (See All Components under General Maintenance).
8. Provide pictures or video of any issues via email as requested by the service technician. Assist with troubleshooting/diagnosing prior to a home visit.

### EXCLUSIONS

This warranty does not cover the following:

1. CONSEQUENTIAL, COLLATERAL, OR INCIDENTAL DAMAGES SUCH AS PROPERTY DAMAGE AND INCIDENTAL EXPENSES RESULTING FROM ANY BREACH OF THIS WRITTEN OR ANY IMPLIED WARRANTY.  
**Note:** Some states do not allow the exclusion or limitation of incidental or consequential damages, so this limitation or exclusion may not apply to you.
2. Service call reimbursement to the consumer. Service call reimbursement to the dealer that does not involve malfunction or defects in workmanship or material, for units that are beyond the warranty period, for units that are beyond the service call reimbursement period, for treadmill not requiring component replacement, or treadmill not in ordinary household use.
3. Damages caused by services performed by persons other than authorized SOLE service companies; use of parts other than original SOLE parts; or external causes such as corrosion (RUST), discoloration of paint or plastic, alterations, modifications, abuse, misuse, accident, improper maintenance (see general maintenance instructions section), including lack of consistent lubrication of the deck, inadequate power supply, natural disasters, or elemental damage (i.e. power surges, lightning storms, water damage, or fire damage.)
4. Products with original serial numbers that have been removed or altered.
5. Products that have been: sold, transferred, bartered, or given to a third party. (Warranties DO NOT transfer.)
6. Products that do not have a warranty registration card on file at SOLE. SOLE reserves the right to request proof of purchase if no warranty record exists for the product.
7. THIS WARRANTY IS EXPRESSLY IN LIEU OF ALL OTHER WARRANTIES EXPRESSED OR IMPLIED, INCLUDING THE WARRANTIES OF MERCHANTABILITY AND/OR FITNESS FOR A PARTICULAR PURPOSE.
8. Product use in any environment other than a residential setting.
9. Warranties outside of North America may vary. Please contact your local dealer for details. Shipping charges may apply to Alaska and Hawaii customers.
10. Warranty will be void if the unit is not in a climate-controlled, insulated environment. (Examples: Garage, outside, carport, etc)

### SERVICE

Keep your bill of sale. Twelve (12) months from the date on the bill of sale or eighteen (18) months from the date of factory shipping as determined by the serial number establishes the labor warranty period should service be required. If service is performed, it is in your best interest to obtain and keep all receipts. This written warranty gives you specific legal rights. You may also have other rights that vary from state to state. Service under this warranty must be obtained by following these steps, in order:

1. Contact your selling authorized SOLE dealer. OR
2. Submit all service requests including serial number, contact information and a brief description of the problem online at <http://www.soletreadmills.com/serviceparts.html>.
3. If there is a question as to where to obtain service, contact our service department at 866-780-7653.
4. If no local service is available, SOLE will repair or replace the parts, at SOLE's option, within the warranty period at no charge for parts. All transportation costs, both to our factory and upon return to the owner, are the responsibility of the owner. The owner is responsible for adequate packaging upon return to SOLE. SOLE is not responsible for damages that occur during shipping. Make all freight damage claims with the appropriate freight carrier. DO NOT SHIP ANY UNIT TO OUR FACTORY WITHOUT A RETURN AUTHORIZATION NUMBER. All units arriving without a return authorization number will be refused.

5. The service department assists in troubleshooting prior to sending a field technician. SOLE may request pictures and video via email of issues to help with diagnosing.

**Before returning your Sole product to any retailer, or if you require any assistance with assembly or technical support please call us first for assistance at 866-780-7653. Thank you for your Sole purchase.**

**SOLE**<sup>™</sup>  
FITNESS