

RITFIT

LEG PRESS MACHINE BLP02

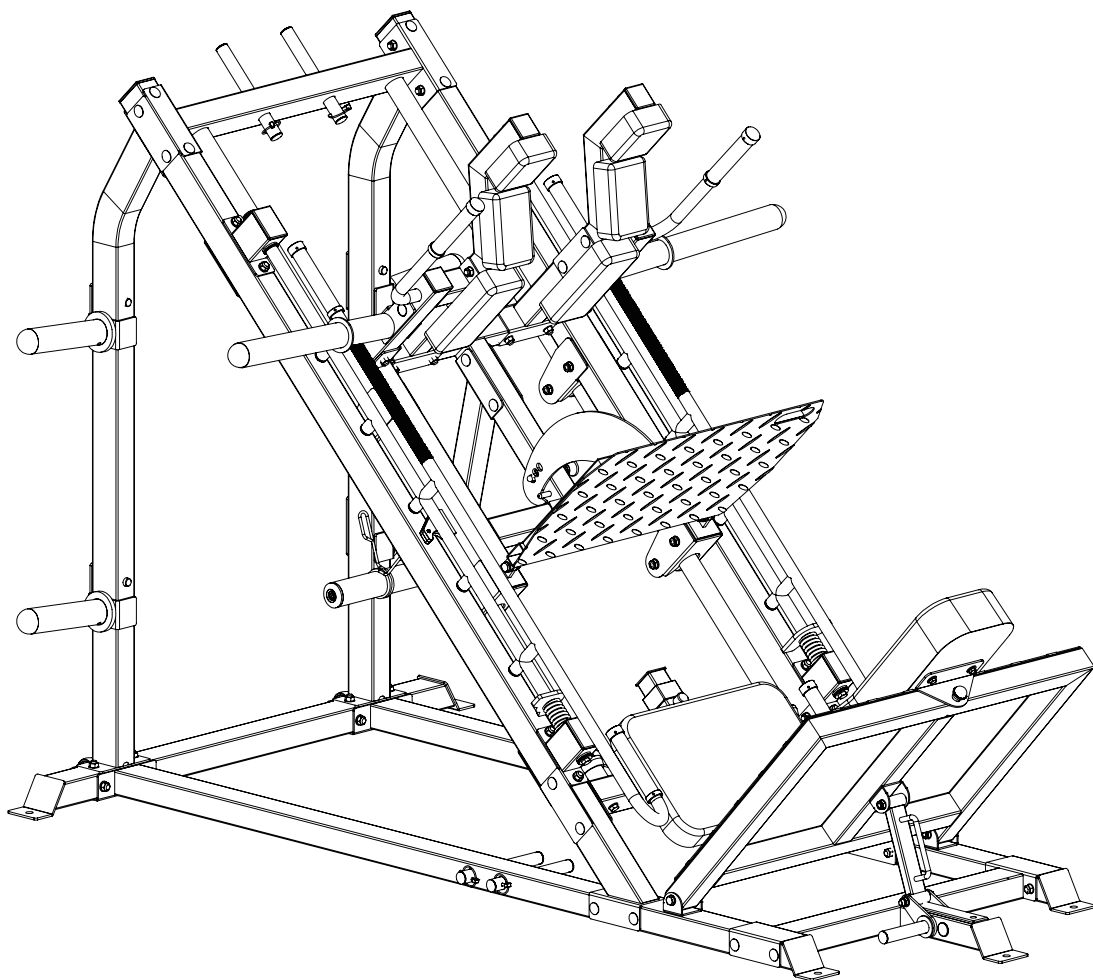

OWNER'S MANUAL & ASSEMBLY INSTRUCTIONS

SAFETY & PRECAUTIONS

IMPORTANT: READ ALL PRECAUTIONS CAREFULLY BEFORE USING THIS PRODUCT. RETAIN OWNER'S MANUAL FOR FUTURE REFERENCE.

Note: This item is shipped in an unusual shaped box. Please hold on to the box until you feel there's no need to return the product. Place the manual in a safe place in your home or office.

In the event should you find this product has either a defective or a missing part, do not use substitute parts or try to use the unit in an incomplete form. Please contact RITFIT for a replacement.

Additional features on products may be added during seasonal production but may not be featured in line art diagrams at time of production. Changes of such will not affect the performance or assembly of the unit. If you would like further clarification during your assembly process please feel free to contact RITFIT for direction.

This product has been designed for light commercial or home use only. Light commercial can be defined as a location with multiple users but not in a membership setting. Examples would be hotels, fire departments, high schools, etc. Commercial use would include, but not limited to, locations that accept membership for use of equipment.

This exercise equipment was designed and built for optimum safety. However certain operator precautions apply whenever you operate a piece of exercise equipment. Please note the following safety procedures:

1. Keep children and pets away from this equipment.
2. Always inspect equipment prior to use to assure the structural integrity. Some parts may need occasional maintenance due to wear and tear.
3. Lubricate moving parts as needed (depends on use but once a month is a good rule to follow).
4. One person at a time should use this equipment unless otherwise designed for safety (example: spotter stand on some weight benches).
5. If dizziness, nausea, chest pains, or any other abnormal symptoms are experienced while using this equipment, stop the workout at once. CONSULT A PHYSICIAN IMMEDIATELY.
6. Always use this equipment on a level surface. Do not use outdoors or near water.
7. Before using this equipment, always do stretching exercise to warm up.
8. Keep hands and feet away from any moving parts that are not intended to have body parts near them while in use.
9. Do not insert any object into any openings unless object is supposed to be inserted into a particular place (such as a pin in a weight stack).
10. Use this equipment only for its intended use as described in manual.
11. Always wear appropriate workout clothing and shoes when exercising. DO NOT WEAR ROBES OR OTHER CLOTHING THAT COULD BECOME CAUGHT IN THE EQUIPMENT.
12. BEFORE BEGINNING ANY EXERCISE PROGRAM, CONSULT YOUR PHYSICIAN.
13. If you have any questions, please e-mail our customer service at support@ritfitsports.com.

PRODUCT USE AND MAINTENANCE

The RitFit Leg Press Machine should be repaired only by authorized persons. NEVER modify the RitFit Leg Press Machine or attempt to repair the unit equipment without first calling our Customer Service Department. Always notify authorized personnel to make such repairs.

WARNING

- **THE MAXIMUM TOTAL STATIC LOADING CAPACITY SHALL NOT EXCEED 2000 LBS (908 KG).**
- **KEEP CHILDREN UNDER 13 AND PETS AWAY FROM THE LEG PRESS MACHINE.**
- **INSPECT AND TIGHTEN ALL PARTS EACH TIME AND REPLACE ANY WORN PARTS IMMEDIATELY.**

WARRANTY

A. What's Covered Under RitFit LLC's Basic Warranty?

Basic Warranty.

B. Who Is Covered?

You are covered by the Basic Warranty if you are a purchaser for use of the RitFit Leg Press Machine.

C. What's Covered?

The Basic Warranty covers the cost of all parts and labor needed to repair any item on your leg press machine when it left the manufacturing plant that is defective in material, workmanship or factory preparation. These warranty repairs or adjustments will be made by RitFit at no charge, using new or remanufactured parts.

D. When It Begins?

The Basic Warranty begins on the day of order.

E. When It Ends?

The Basic Warranty for the main frame lasts for 36 months from the date it begins, but the parts are covered only for 12 months.

F. What's Not Covered?

Please note that while the standard Basic Warranty applies to defects in material and/or workmanship, it does not cover the leg press machine's matte finish appearance. Maintaining the matte finish appearance is solely the responsibility of the owner. Basic Warranty doesn't cover damage caused by environmental factors such as airborne fallout, insect damage, chemicals, salt, and ocean spray. Nor do your warranty cover damage caused by hailstorms, windstorms, tornadoes, sandstorms, lightning, floods, and earthquakes. Your warranty does not cover conditions resulting from anything impacting the leg press machine.

G. How To Contact Us?

To ensure you receive the best technical support please visit www.ritfitsports.com to register your warranty. Customers with registered warranties are given a profile that allows for easier support and for us to contact you with important product notifications. If any parts are missing, worn, damaged or broken before the assembly, or you ever need to replace the parts, please contact us at support@ritfitsports.com.

BEFORE YOU BEGIN

Thank you for selecting the versatile RITFIT® Leg Press Machine. RITFIT® Leg Press Machine is designed to be used with weight training system to help you develop your lower muscle group of the body.

For your benefit, read this manual carefully before using the Leg Press Machine. If you have additional questions, please email our Customer Service Department at support@ritfitsports.com. To help us assist you, please note the product model number and serial number before calling. The model number is **BLP02**.

BEFORE READING FURTHER, PLEASE REVIEW THE DRAWING BELOW AND FAMILIARIZE YOURSELF WITH THE PARTS THAT ARE LABELED. *NOTE: THE LEFT AND RIGHT DIRECTION OF ACCESSORIES ARE ACCORDING TO THE DIRECTION BELOW.

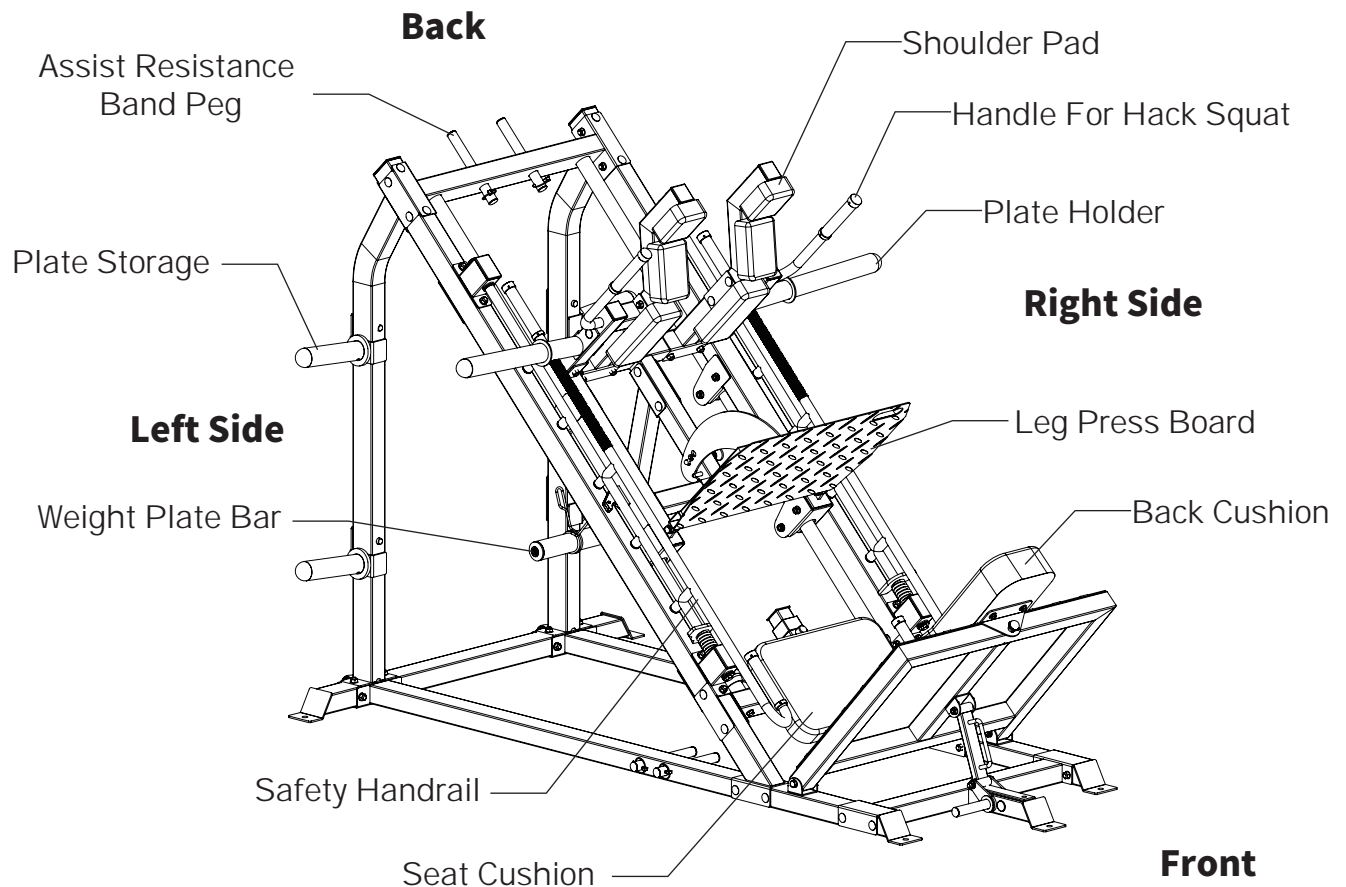

CAPACITY: 2000 LBS

PARTS LIST

·FASTENER AND TOOLS

| NO. | DESCRIPTION | QUANTITY |
|-----|-------------------------|----------|
| a | M10x90 Square Neck Bolt | 24 |
| b | M10x70 Square Neck Bolt | 28 |
| c | M10x80 Hex Bolt | 1 |
| d | M10x70 Hex Bolt | 3 |
| e | M10x35 Hex Bolt | 2 |
| f | M10x20 Hex Bolt | 6 |
| g | M8x85 Hex Bolt | 2 |
| h | M8x65 Hex Bolt | 12 |
| i | M8x20 Hex Bolt | 2 |



(a) M10x90 Square Neck Bolt
24x

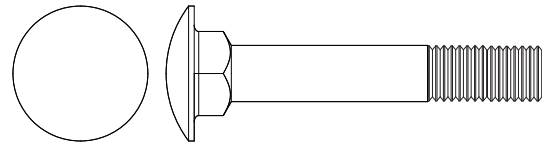

(b) M10x70 Square Neck Bolt
28x

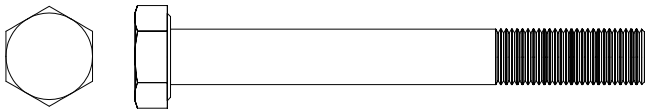

(c) M10x80 Hex Bolt
1x

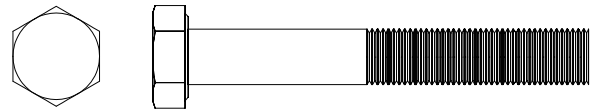

(d) M10x70 Hex Bolt
3x

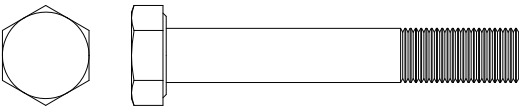

(e) M10x35 Hex Bolt
2x

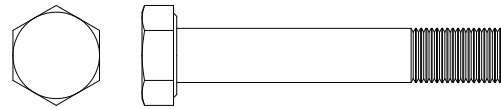

(f) M10x20 Hex Bolt
6x

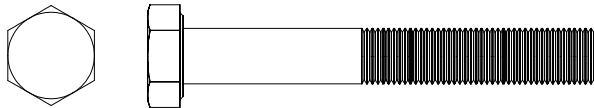

(g) M8x85 Hex Bolt
2x

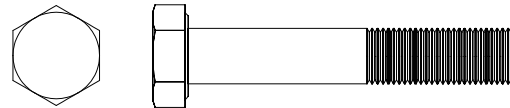

(h) M8x65 Hex Bolt
12x

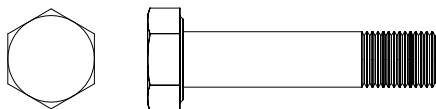

(i) M8x20 Hex Bolt
2x

PARTS LIST

·FASTENER AND TOOLS

| NO. | DESCRIPTION | QUANTITY |
|-----|-------------------------|----------|
| j | 10x30 Washer | 2 |
| k | M10 Washer | 68 |
| l | M8 Washer | 16 |
| m | M10 Nut | 58 |
| n | Open-ended Wrench 14-17 | 2 |
| o | Hex Key | 1 |

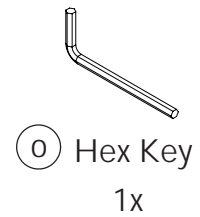
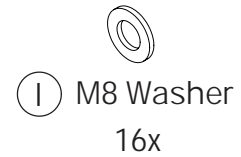
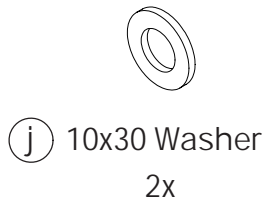

How To Measure

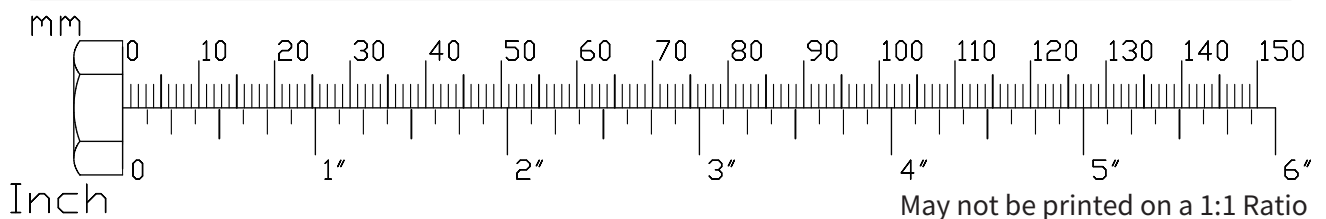
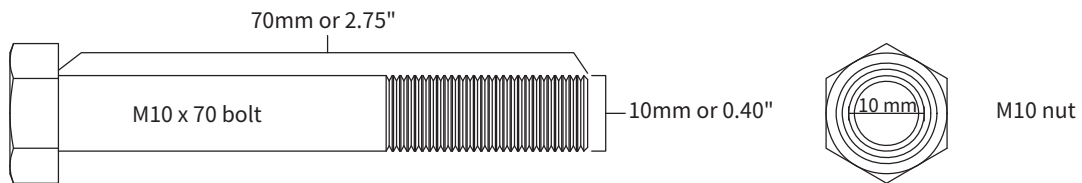

PARTS LIST

•PACKED IN THE BOX

| NO. | DESCRIPTION | QUANTITY |
|-----|-------------------------|----------|
| 1 | Foot Plate Bottom Frame | 1 |
| 2 | Bottom Main Frame | 2 |
| 3 | Bottom Cross Beam | 1 |
| 4 | Rear Side Frame | 2 |
| 5 | Guiding Rod | 2 |
| 6 | Side Frame | 2 |
| 7 | Upper Cross Beam | 1 |
| 8 | Bolt Plate (Large) | 4 |
| 9 | Bolt Plate (Small) | 2 |
| 10 | Slider | 1 |
| 11 | Seat Cushion Frame | 1 |
| 12 | Safety Handrail (Left) | 1 |
| 13 | Safety Handrail (Right) | 1 |

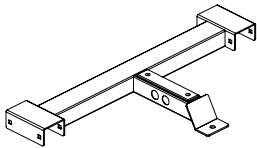

① Foot Plate Bottom Frame
1x

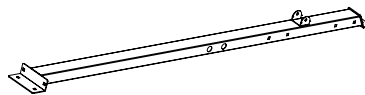

② Bottom Main Frame
2x

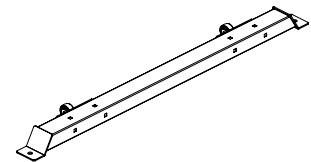

③ Bottom Cross Beam
1x

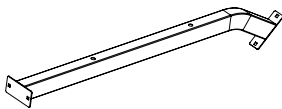

④ Rear Side Frame
2x

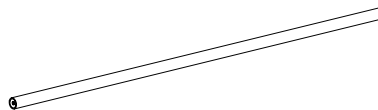

⑤ Guiding Rod
2x

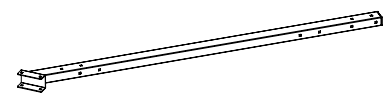

⑥ Side Frame
2x

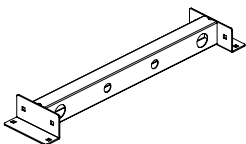

⑦ Upper Cross Beam
1x

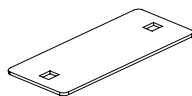

⑧ Bolt Plate (Large)
4x

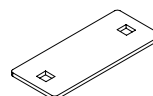

⑨ Bolt Plate (Small)
2x

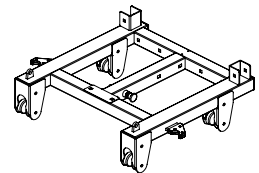

⑩ Slider
1x

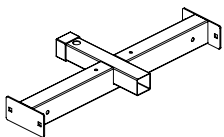

⑪ Seat Cushion Frame
1x

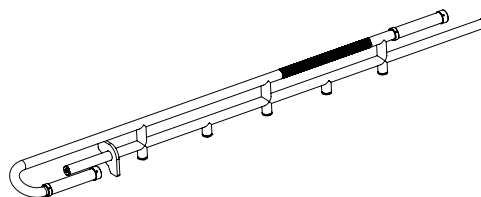

⑫ Safety Handrail (Left)
1x

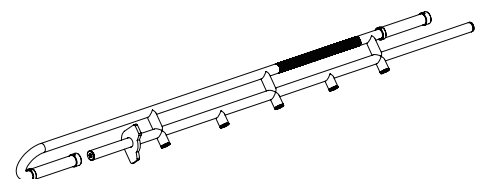

⑬ Safety Handrail (Right)
1x

PARTS LIST

• PACKED IN THE BOX

| NO. | DESCRIPTION | QUANTITY |
|-----|----------------------------------|----------|
| 14 | Foot Plate | 1 |
| 15 | Leg Press Board | 1 |
| 16 | Leg Press Board Adjustment Piece | 1 |
| 17 | Handle Bar Frame | 2 |
| 18 | Weight Plate Bar | 1 |
| 19 | Plate Holder (Left) | 1 |
| 20 | Plate Holder (Right) | 1 |
| 21 | Weight Plate Bar Frame | 1 |
| 22 | Shoulder Pad Frame | 2 |
| 23 | Back Cushion | 1 |
| 24 | Seat Cushion | 1 |
| 25 | Shoulder Pad (Large) | 2 |
| 26 | Shoulder Pad (Medium) | 2 |
| 27 | Shoulder Pad (Small) | 2 |

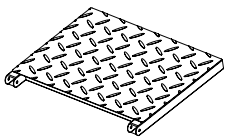

⑭ Foot Plate
1x

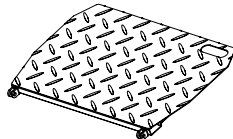

⑮ Leg Press Board
1x



⑯ Leg Press Board Adjustment Piece
1x

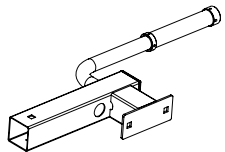

⑰ Handle Bar Frame
2x

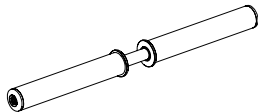

⑱ Weight Plate Bar
1x

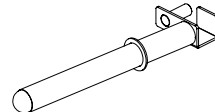

⑲ Plate Holder (Left)
1x

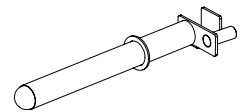

⑳ Plate Holder (Right)
1x

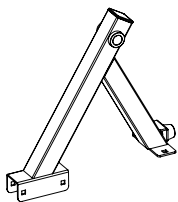

㉑ Weight Plate Bar Frame
1x

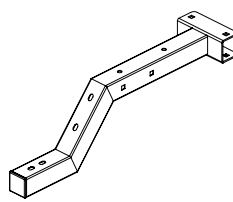

㉒ Shoulder Pad Frame
2x

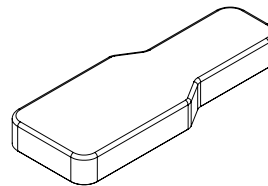

㉓ Back Cushion
1x

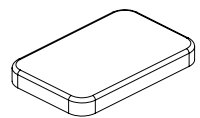

㉔ Seat Cushion
1x

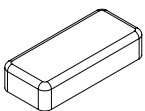

㉕ Shoulder Pad (Large)
2x

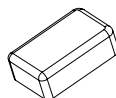

㉖ Shoulder Pad (Medium)
2x



㉗ Shoulder Pad (Small)
2x

PARTS LIST

• PACKED IN THE BOX

| NO. | DESCRIPTION | QUANTITY |
|-----|--------------------------------|----------|
| 28 | Back Cushion Fixing Plate | 1 |
| 29 | Back Cushion Pin | 1 |
| 30 | Safety Limit Tube | 1 |
| 31 | Pin | 7 |
| 32 | Safety Limit Tube Pin | 1 |
| 33 | Plate Storage (Left) | 2 |
| 34 | Plate Storage (Right) | 2 |
| 35 | Spring | 2 |
| 36 | Resistance Band Peg | 7 |
| 37 | Guiding Rod Peg | 2 |
| 38 | Handrail Connection Frame | 4 |
| 39 | Collar | 4 |
| 40 | Safety Handrail Ring | 2 |
| 41 | Foot Plate Adjustment Piece | 2 |
| 42 | Foot Plate Adjustment Handrail | 1 |

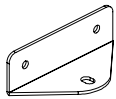

②⑧ Back Cushion Fixing Plate
1x

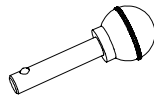

②⑨ Back Cushion Pin
1x

(②⑨ is pretty small, maybe packed together with other fasteners)

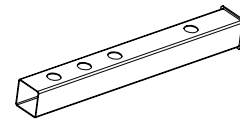

③⑩ Safety Limit Tube
1x



③① Pin
7x

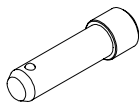

③② Safety Limit Tube Pin
1x

(③② is pretty small, maybe packed together with other fasteners)

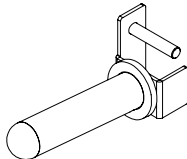

③③ Plate Storage (Left)
2x

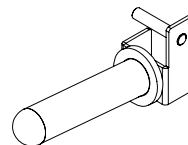

③④ Plate Storage (Right)
2x

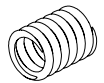

③⑤ Spring
2x

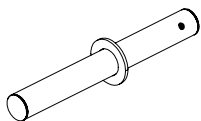

③⑥ Resistance Band Peg
7x



③⑦ Guiding Rod Peg
2x

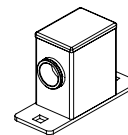

③⑧ Handrail Connection Frame
4x

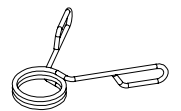

③⑨ Collar
4x



④⑩ Safety Handrail Ring
2x

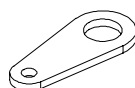

④① Foot Plate Adjustment Piece
2x

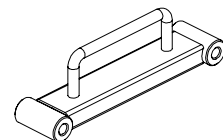

④② Foot Plate Adjustment Handrail
1x

ASSEMBLY AND ADJUSTMENT

STEP 1 (Two People Are Required.)

| NO. | DESCRIPTION | QUANTITY |
|-----|-------------------------|----------|
| 1 | Foot Plate Bottom Frame | 1 |
| 2 | Bottom Main Frame | 2 |
| a | M10x90 Square Neck Bolt | 4 |
| k | M10 Washer | 4 |
| m | M10 Nut | 4 |

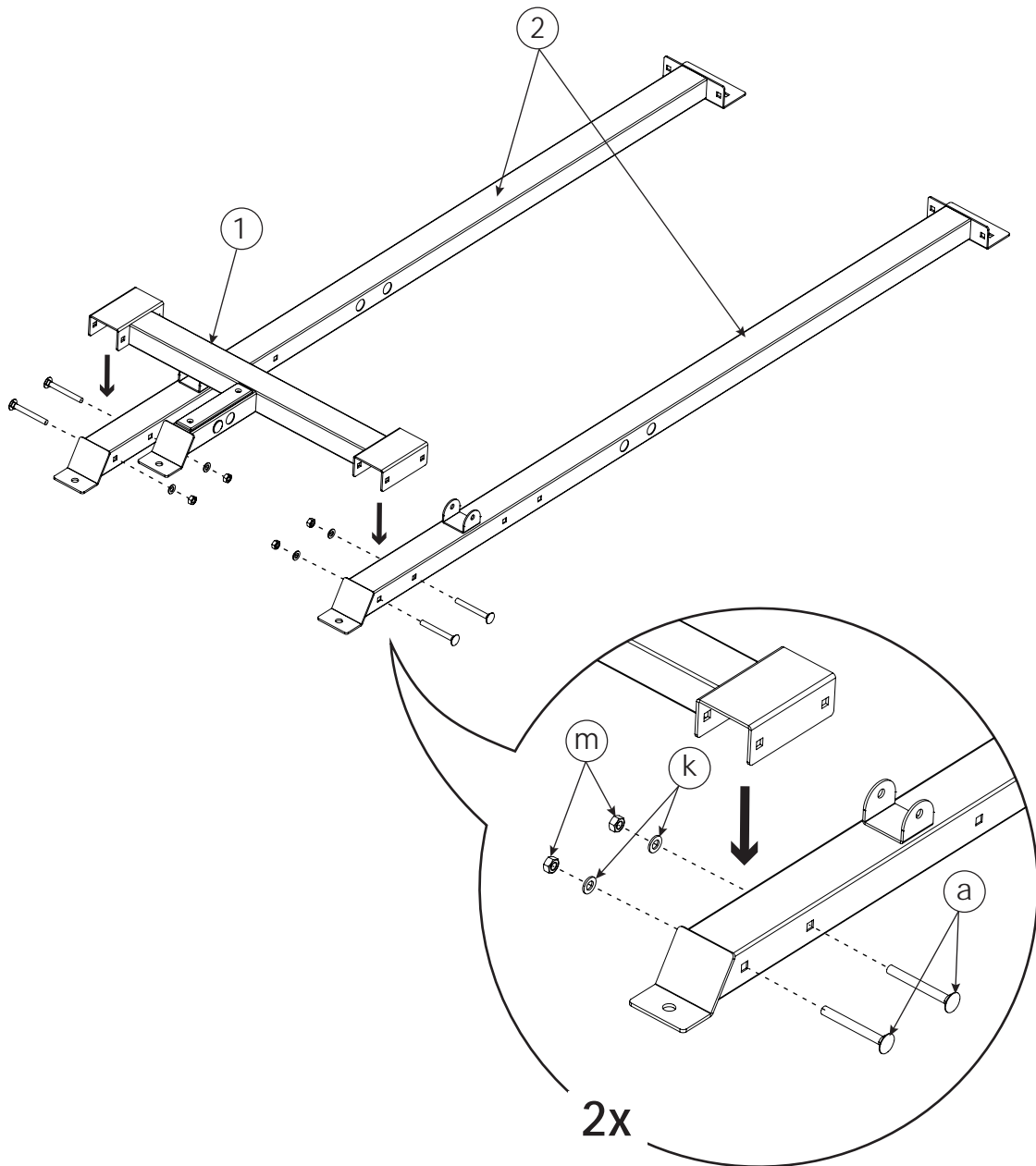

ASSEMBLY AND ADJUSTMENT

STEP 2 (Two People Are Required.)

| NO. | DESCRIPTION | QUANTITY |
|-----|-------------------------|----------|
| 3 | Bottom Cross Beam | 1 |
| a | M10x90 Square Neck Bolt | 4 |
| k | M10 Washer | 4 |
| m | M10 Nut | 4 |

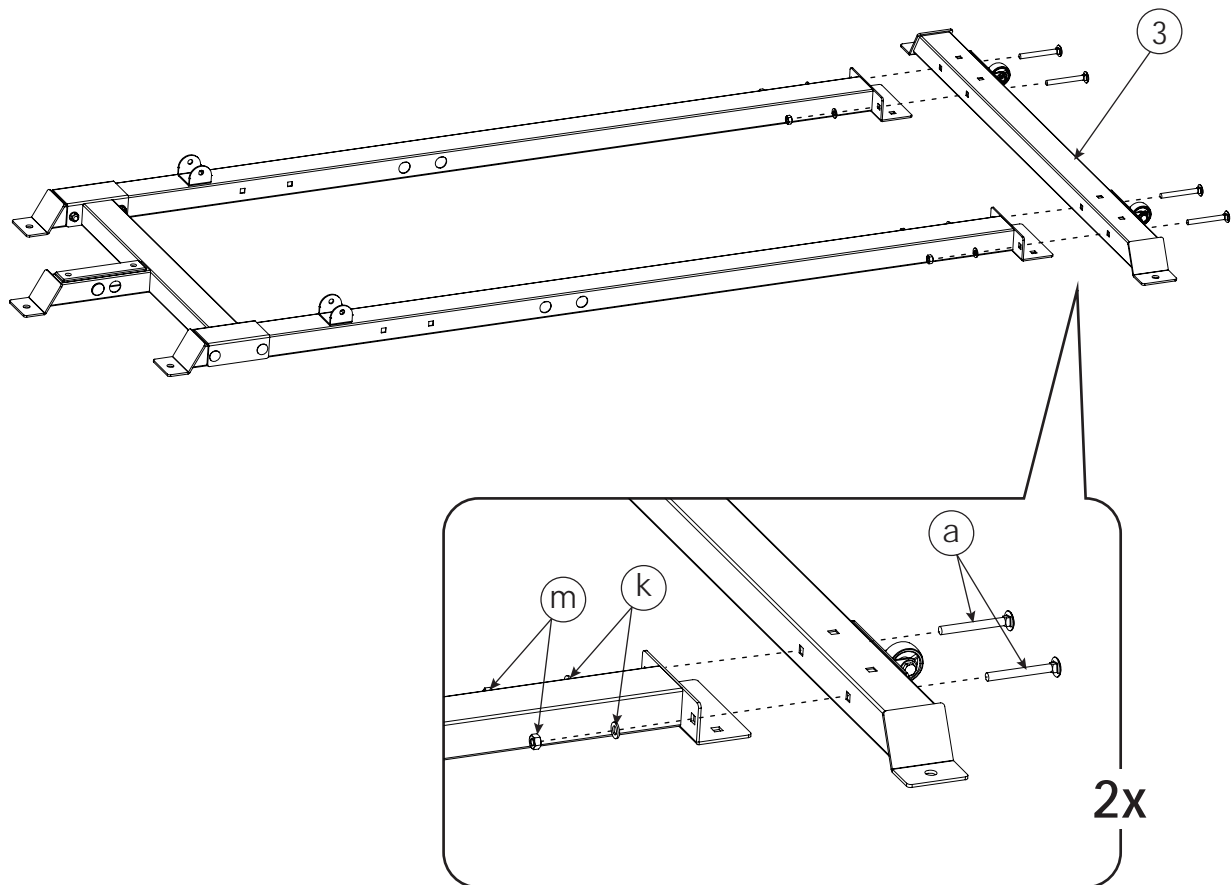

ASSEMBLY AND ADJUSTMENT

STEP 3 (Two People Are Required.)

| NO. | DESCRIPTION | QUANTITY |
|-----|-------------------------|----------|
| 4 | Rear Side Frame | 2 |
| b | M10x70 Square Neck Bolt | 4 |
| k | M10 Washer | 4 |
| m | M10 Nut | 4 |

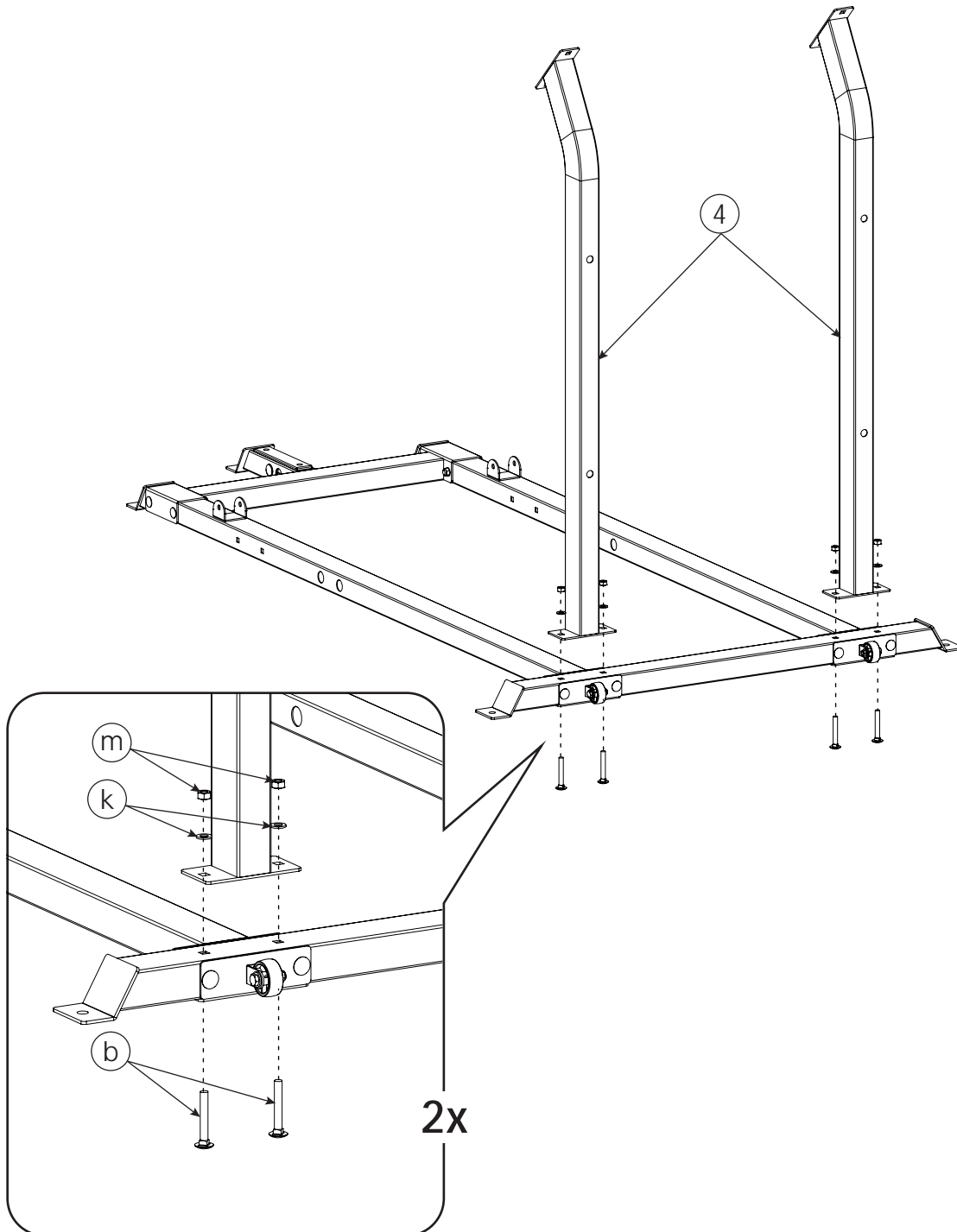

ASSEMBLY AND ADJUSTMENT

STEP 4 (Two People Are Required.)

| NO. | DESCRIPTION | QUANTITY |
|-----|-------------------------|----------|
| 6 | Side Frame | 2 |
| a | M10x90 Square Neck Bolt | 4 |
| k | M10 Washer | 4 |
| m | M10 Nut | 4 |

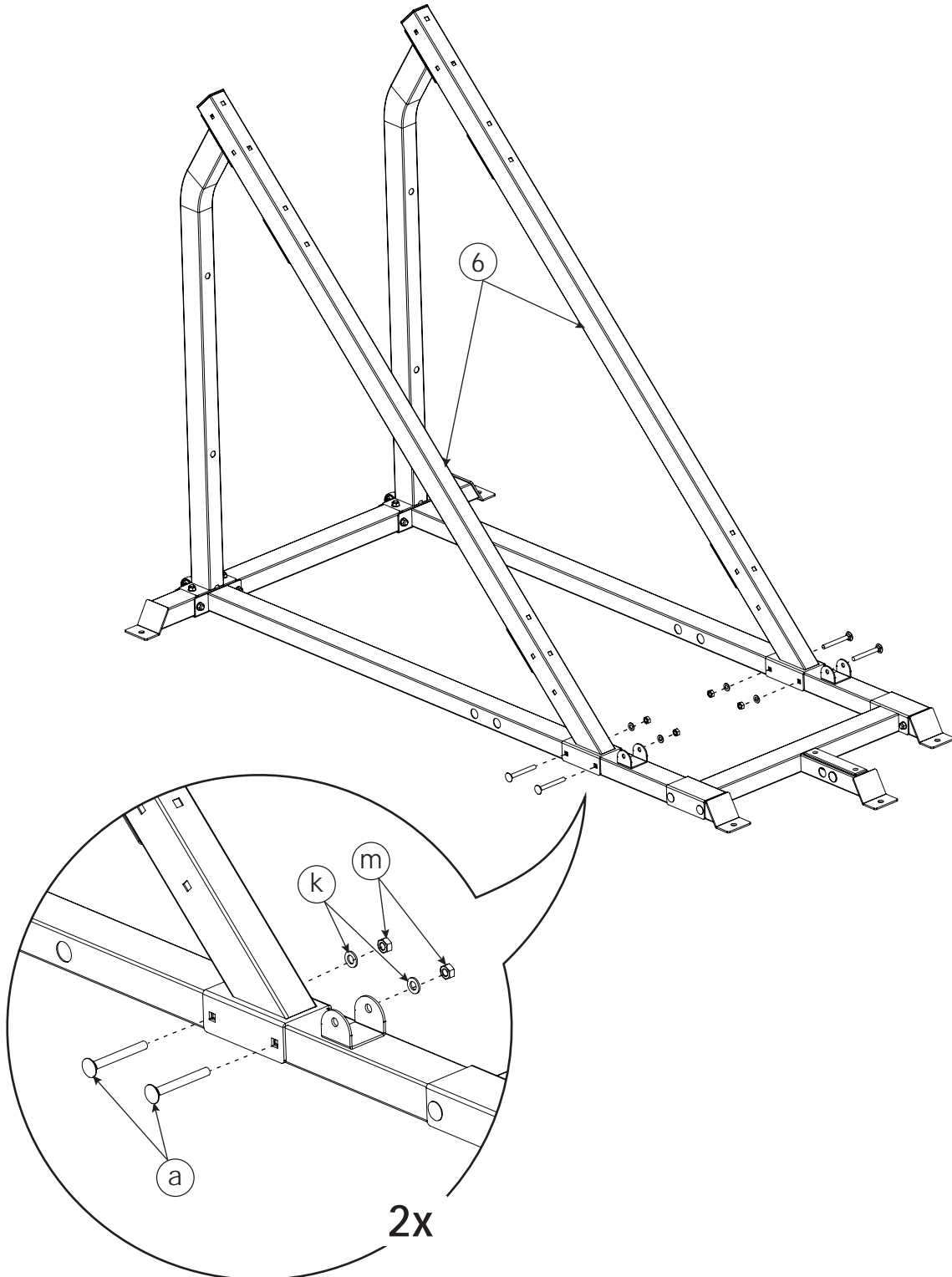

ASSEMBLY AND ADJUSTMENT

STEP 5 (Two People Are Required.)

| NO. | DESCRIPTION | QUANTITY |
|-----|-------------------------|----------|
| 8 | Bolt Plate (Large) | 2 |
| 11 | Seat Cushion Frame | 1 |
| b | M10x70 Square Neck Bolt | 4 |
| k | M10 Washer | 4 |
| m | M10 Nut | 4 |

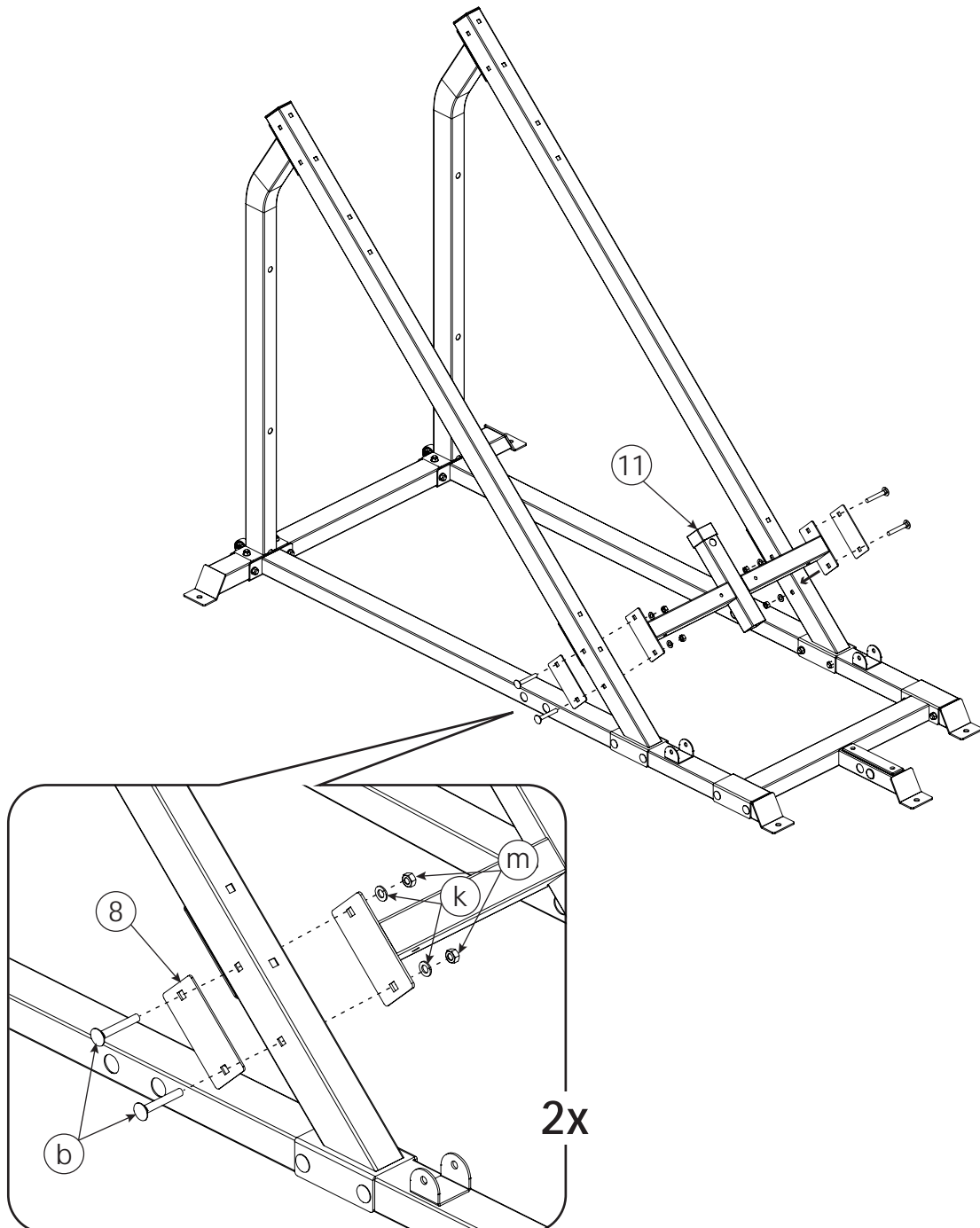

ASSEMBLY AND ADJUSTMENT

STEP 6 (Two People Are Required.)

| NO. | DESCRIPTION | QUANTITY |
|-----|-----------------|----------|
| 5 | Guiding Rod | 2 |
| 37 | Guiding Rod Peg | 2 |
| f | M10x20 Hex Bolt | 2 |
| k | M10 Washer | 2 |

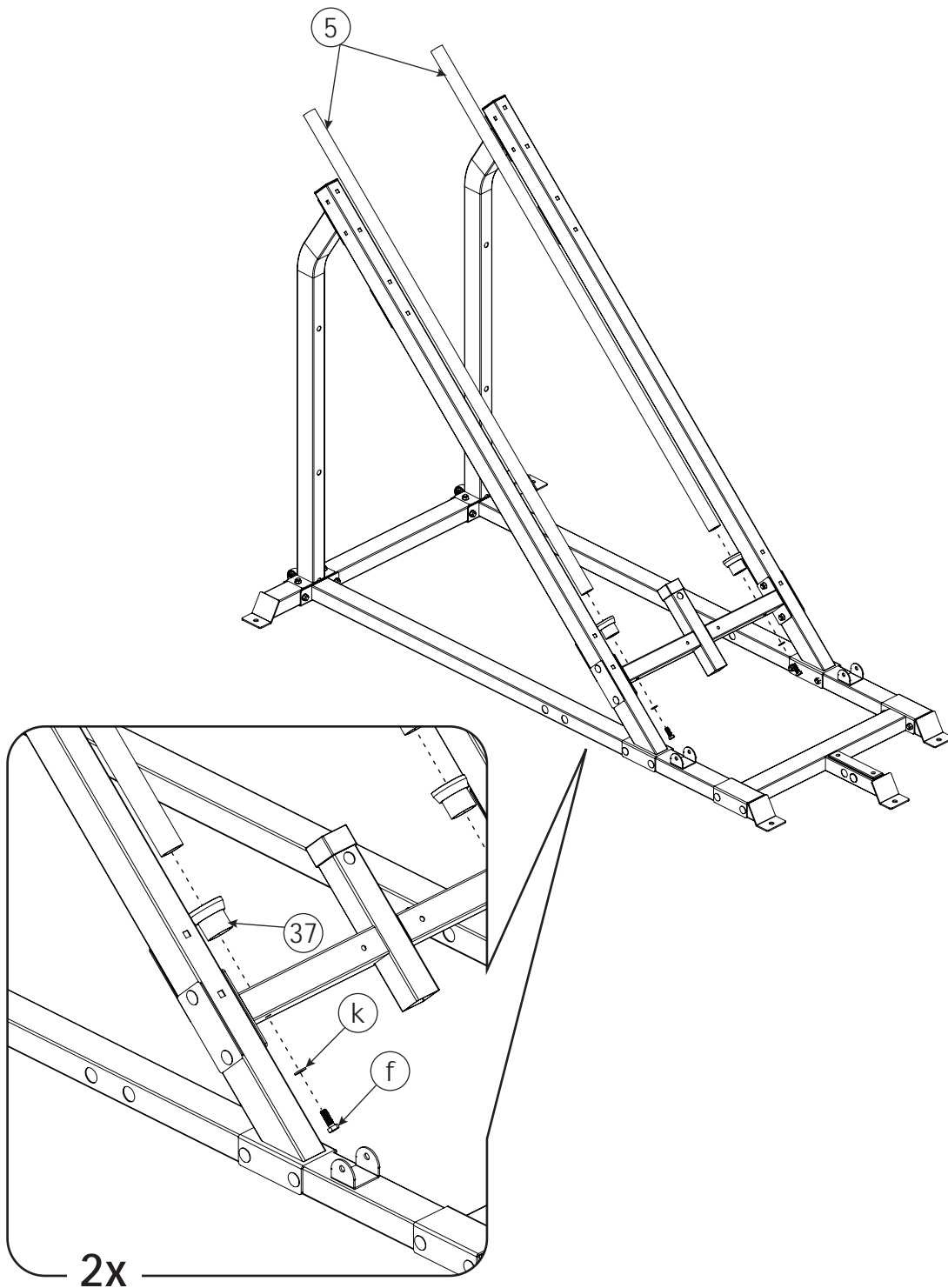

ASSEMBLY AND ADJUSTMENT

STEP 7 (Two People Are Required.)

| NO. | DESCRIPTION | QUANTITY |
|-----|-------------|----------|
| 10 | Slider | 1 |

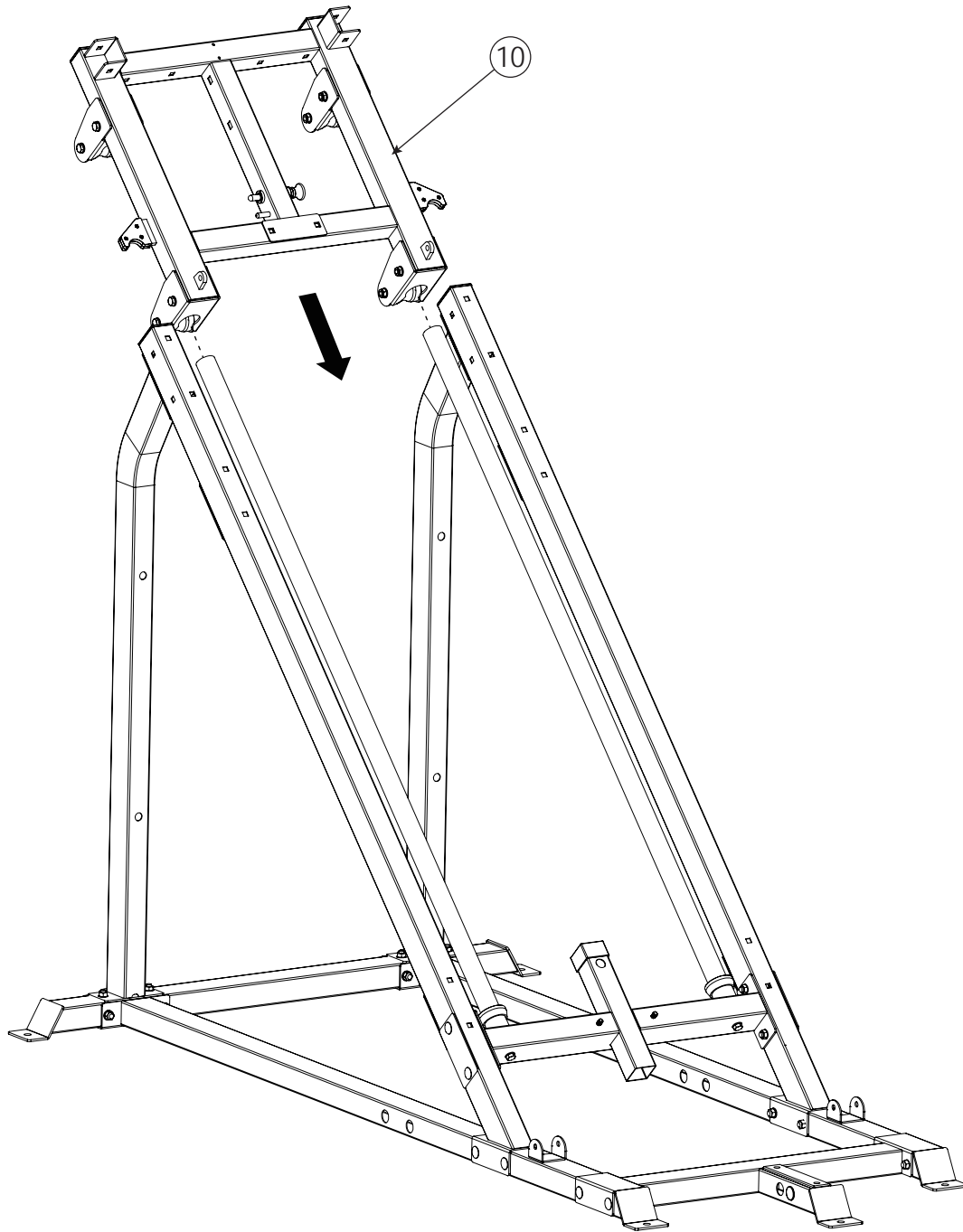

ASSEMBLY AND ADJUSTMENT

STEP 8 (Two People Are Required.)

| NO. | DESCRIPTION | QUANTITY |
|-----|------------------|----------|
| 7 | Upper Cross Beam | 1 |
| f | M10x20 Hex Bolt | 2 |
| k | M10 Washer | 2 |

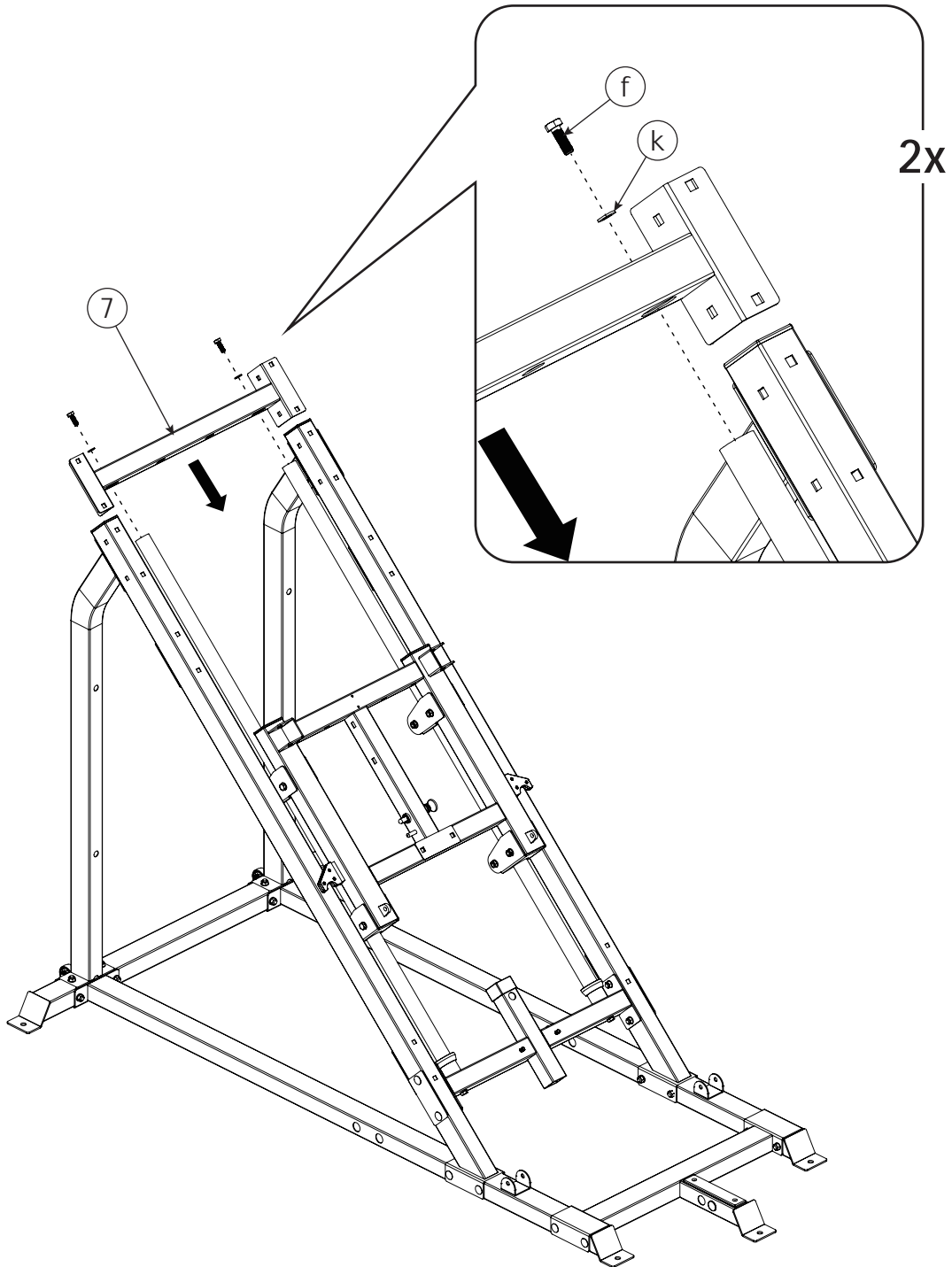

ASSEMBLY AND ADJUSTMENT

STEP 9 (Two People Are Required.)

| NO. | DESCRIPTION | QUANTITY |
|-----|-------------------------|----------|
| 8 | Bolt Plate (Large) | 2 |
| a | M10x90 Square Neck Bolt | 4 |
| b | M10x70 Square Neck Bolt | 4 |
| k | M10 Washer | 8 |
| m | M10 Nut | 8 |

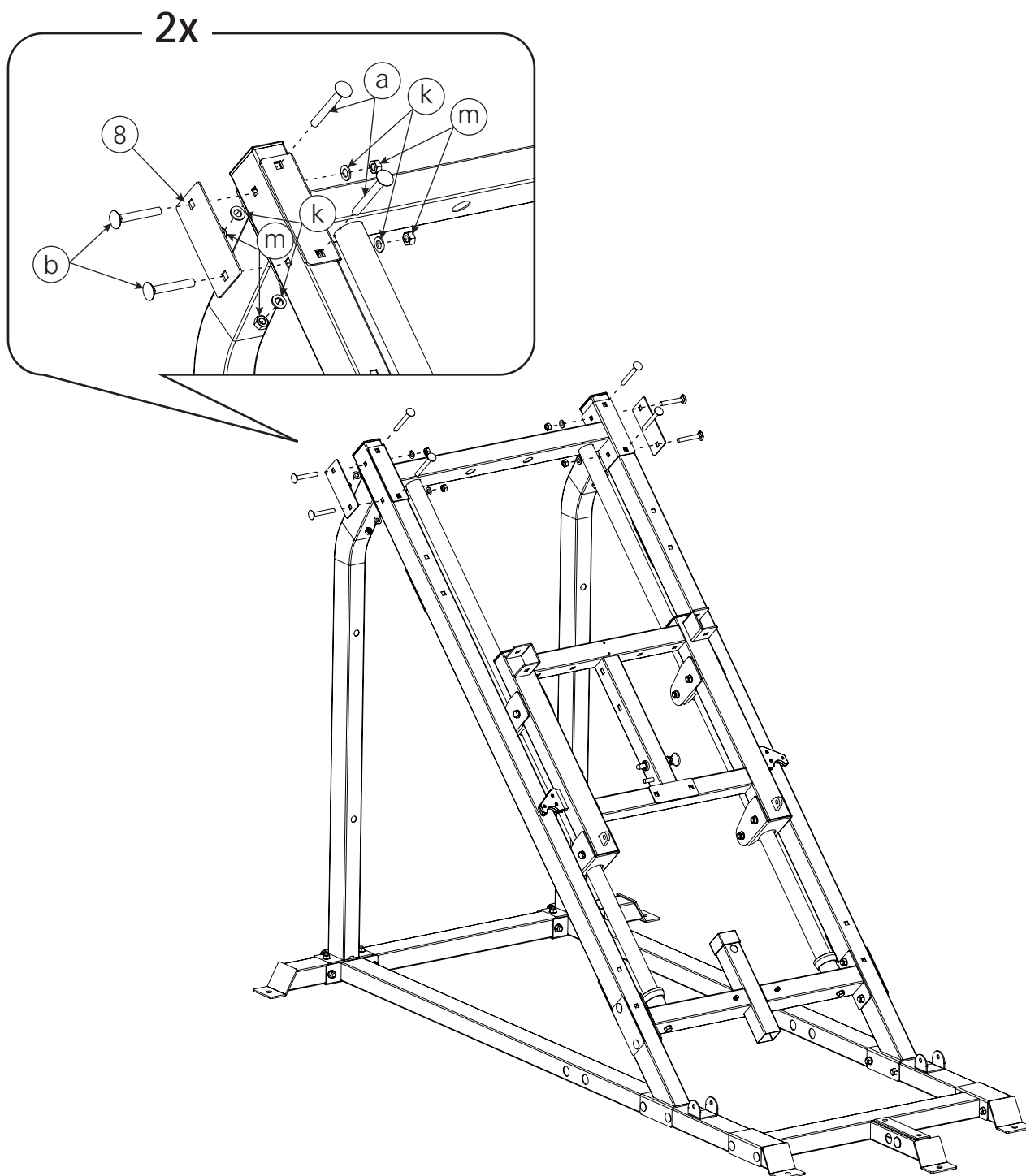

ASSEMBLY AND ADJUSTMENT

STEP 10 (Two People Are Required.)

| NO. | DESCRIPTION | QUANTITY |
|-----|---------------------------|----------|
| 38 | Handrail Connection Frame | 2 |
| a | M10x90 Square Neck Bolt | 4 |
| k | M10 Washer | 4 |
| m | M10 Nut | 4 |

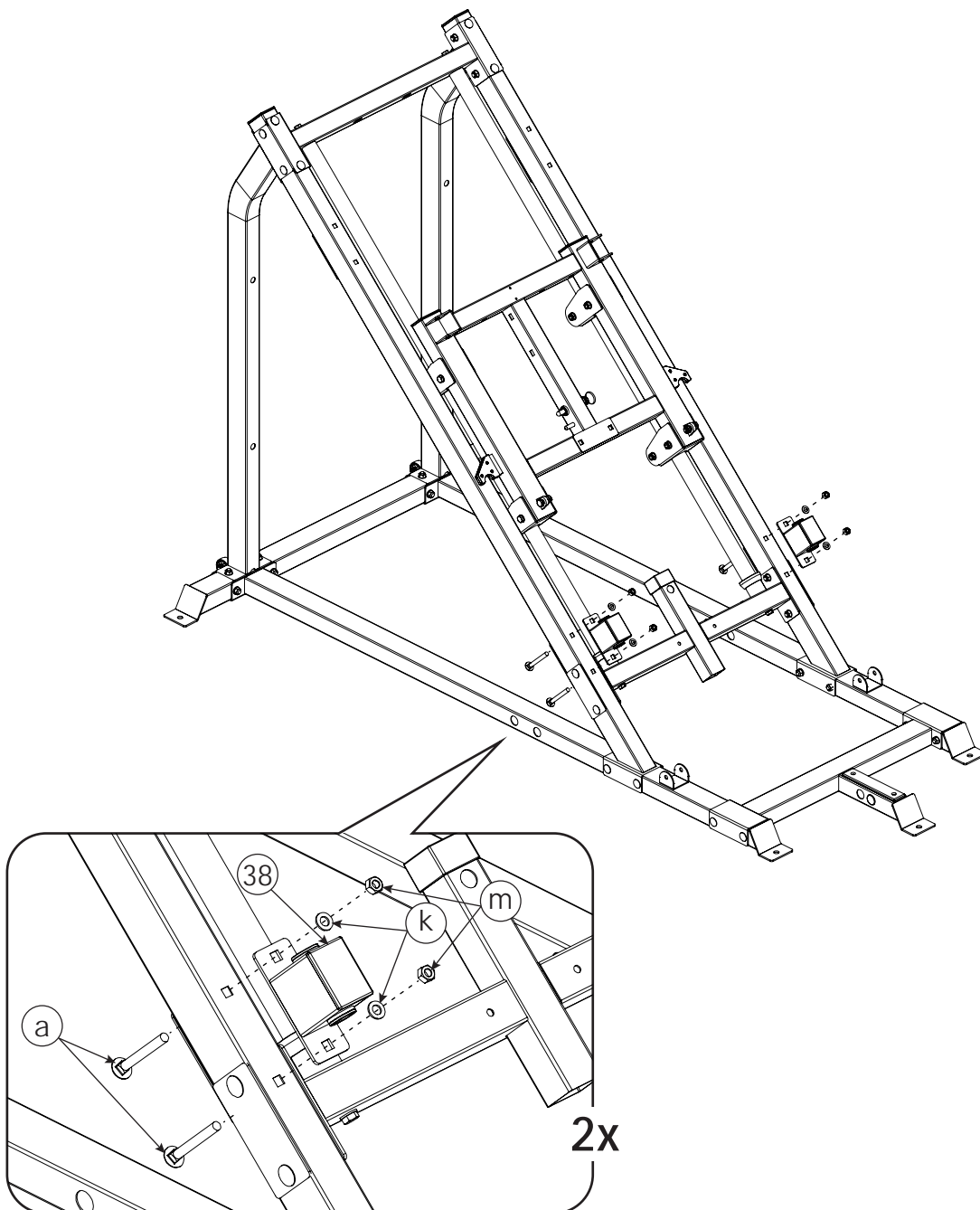

ASSEMBLY AND ADJUSTMENT

STEP 11 (Two People Are Required.)

| NO. | DESCRIPTION | QUANTITY |
|-----|-------------------------|----------|
| 12 | Safety Handrail (Left) | 1 |
| 13 | Safety Handrail (Right) | 1 |
| 35 | Spring | 2 |
| 40 | Safety Handrail Ring | 2 |
| f | M10x20 Hex Bolt | 2 |
| j | 10x30 Washer | 2 |

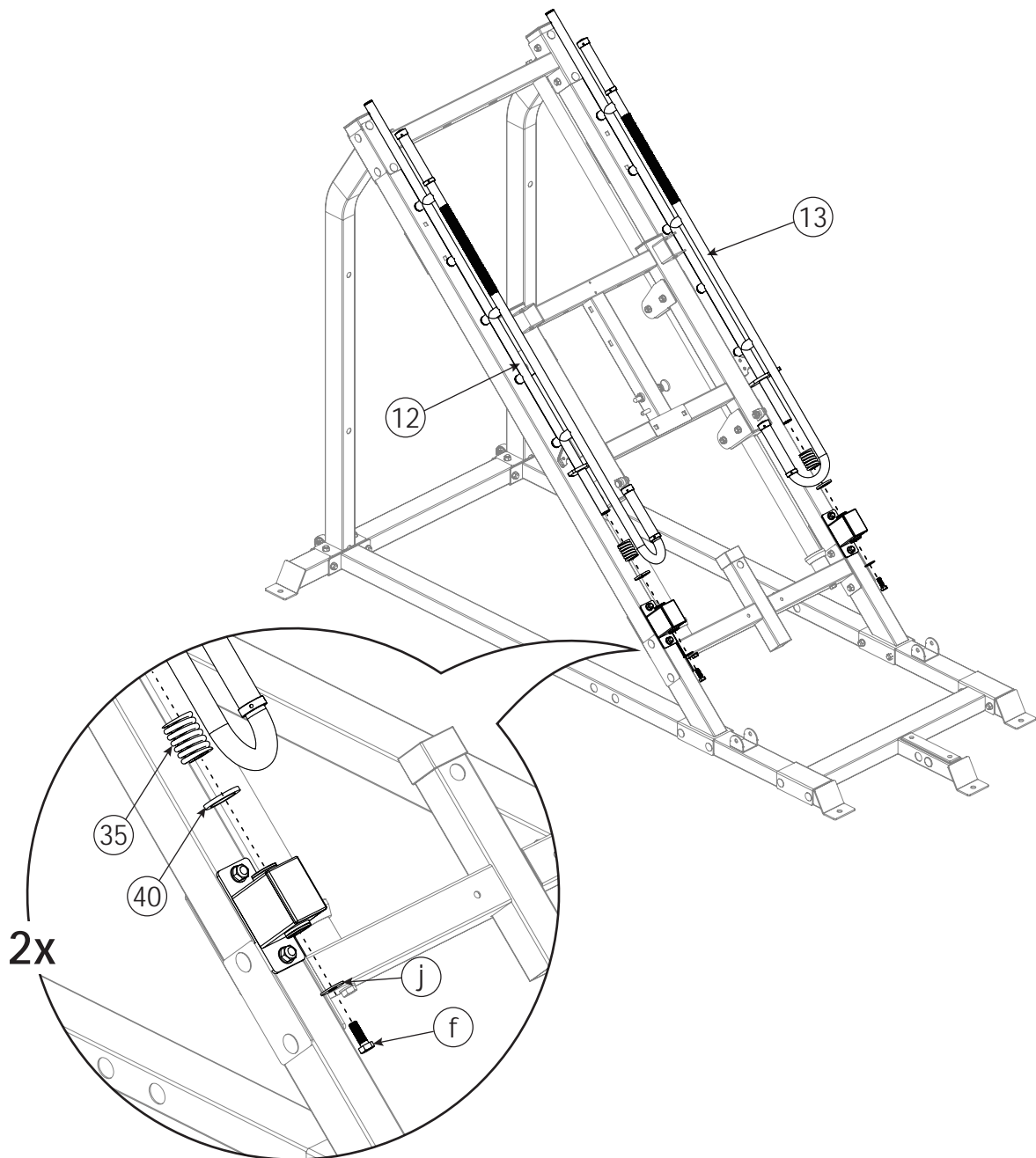

ASSEMBLY AND ADJUSTMENT

STEP 12 (Two People Are Required.)

| NO. | DESCRIPTION | QUANTITY |
|-----|---------------------------|----------|
| 38 | Handrail Connection Frame | 2 |
| a | M10x90 Square Neck Bolt | 4 |
| k | M10 Washer | 4 |
| m | M10 Nut | 4 |

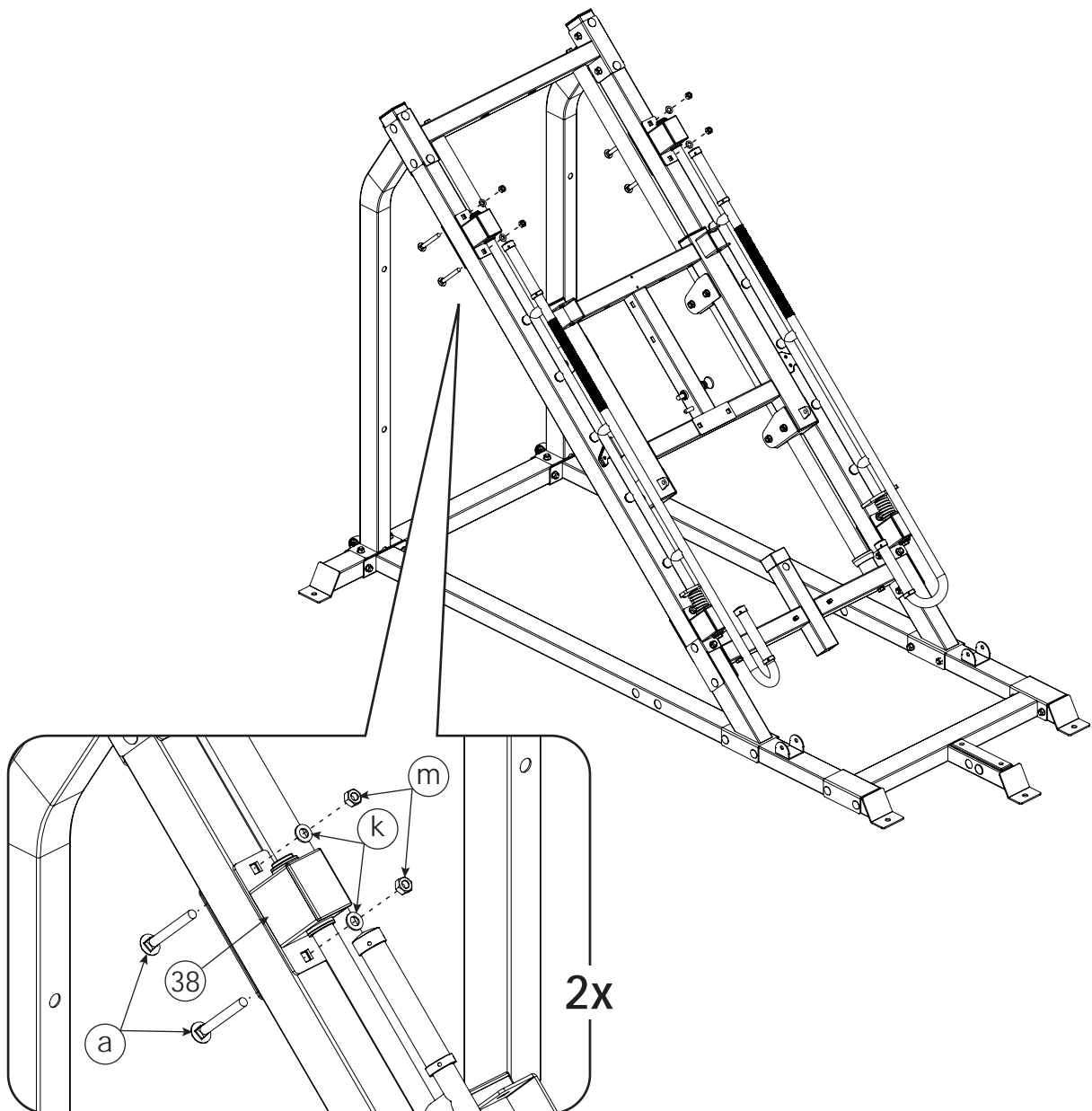

ASSEMBLY AND ADJUSTMENT

STEP 13 (Two People Are Required.)

| NO. | DESCRIPTION | QUANTITY |
|-----|-------------------------|----------|
| 18 | Weight Plate Bar | 1 |
| 21 | Weight Plate Bar Frame | 1 |
| b | M10x70 Square Neck Bolt | 4 |
| k | M10 Washer | 4 |
| m | M10 Nut | 4 |

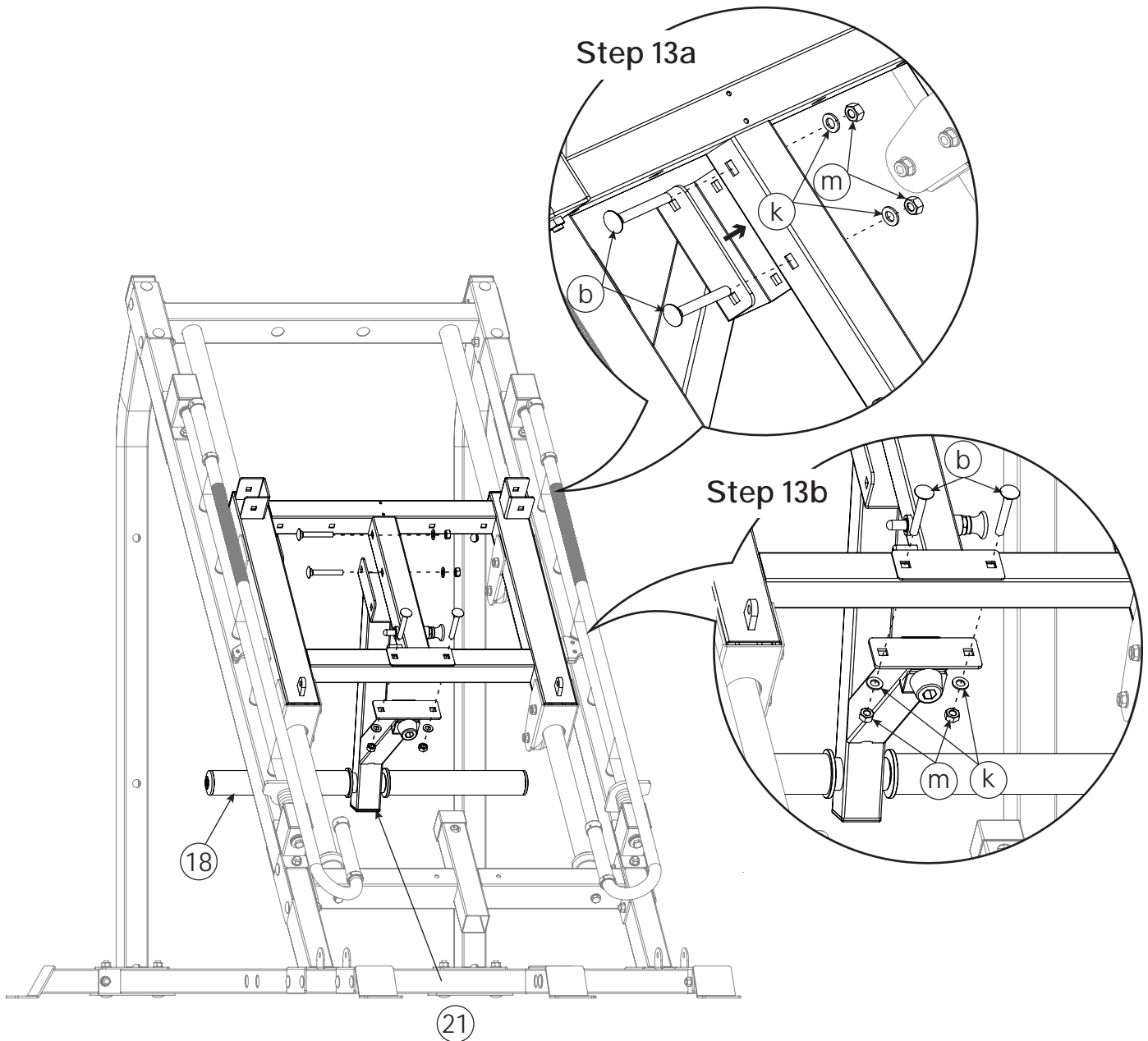

ASSEMBLY AND ADJUSTMENT

STEP 14 (Two People Are Required.)

| NO. | DESCRIPTION | QUANTITY |
|-----|-------------------------|----------|
| 22 | Shoulder Pad Frame | 2 |
| 25 | Shoulder Pad (Large) | 2 |
| 26 | Shoulder Pad (Medium) | 2 |
| 27 | Shoulder Pad (Small) | 2 |
| b | M10x70 Square Neck Bolt | 4 |
| h | M8x65 Hex Bolt | 12 |
| l | M8 Washer | 12 |
| k | M10 Washer | 4 |
| m | M10 Nut | 4 |

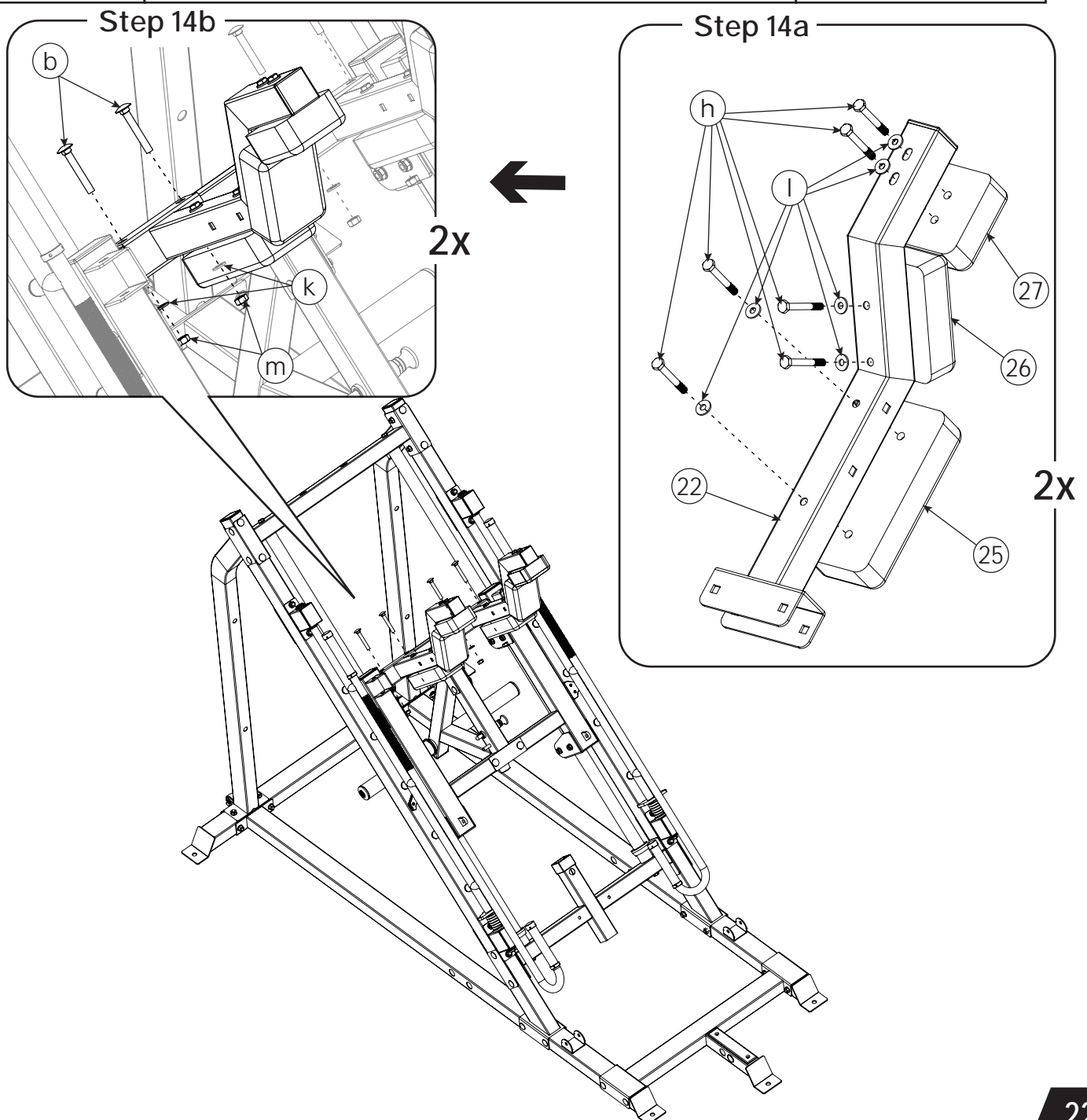

ASSEMBLY AND ADJUSTMENT

STEP 15 (Two People Are Required.)

| NO. | DESCRIPTION | QUANTITY |
|-----|-------------------------|----------|
| 9 | Bolt Plate (Small) | 2 |
| 17 | Handle Bar Frame | 2 |
| b | M10x70 Square Neck Bolt | 6 |
| k | M10 Washer | 6 |
| m | M10 Nut | 6 |

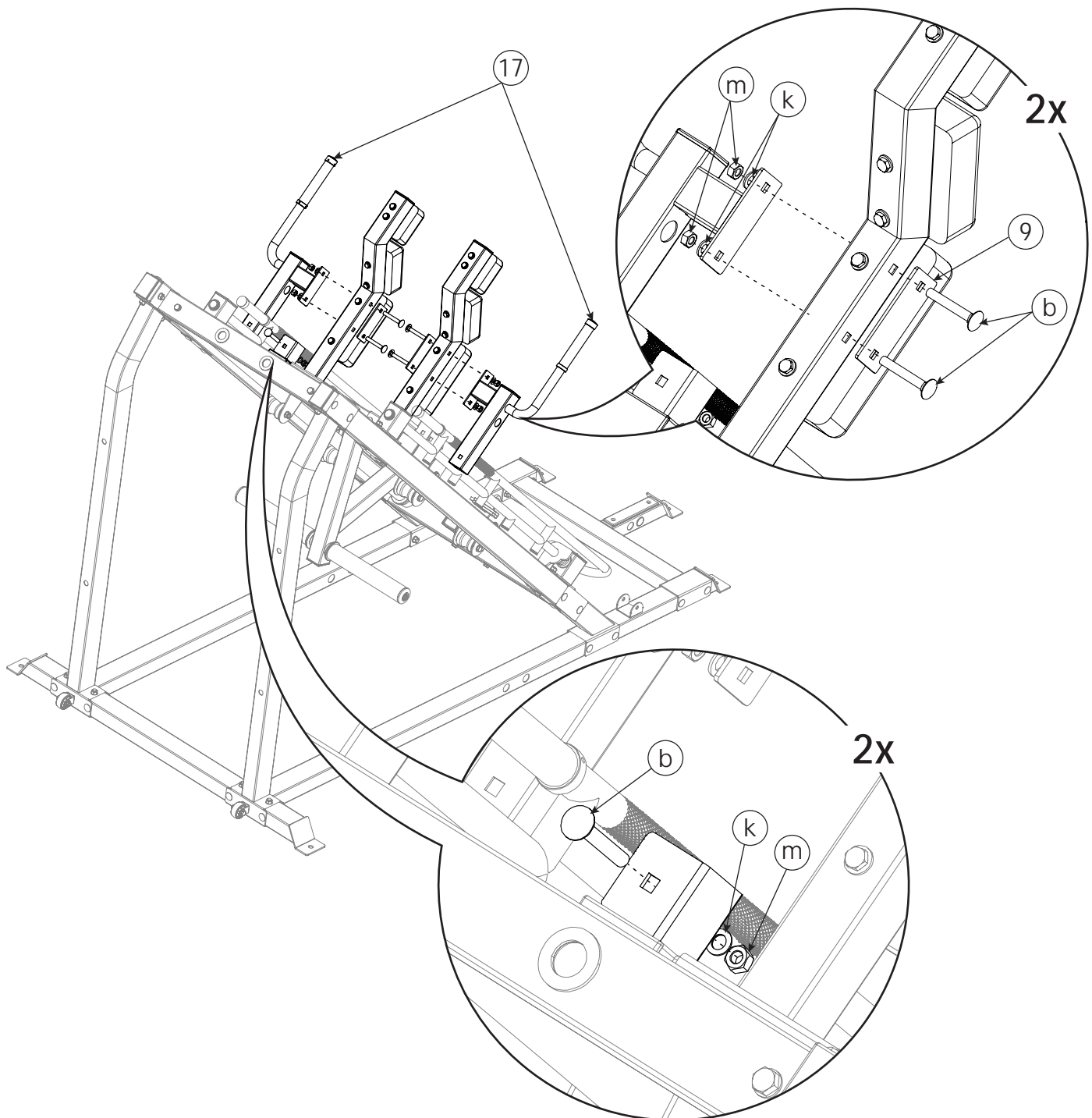

ASSEMBLY AND ADJUSTMENT

STEP 16 (Two People Are Required.)

| NO. | DESCRIPTION | QUANTITY |
|-----|-----------------------|----------|
| 19 | Plate Holder (Left) | 1 |
| 20 | Plate Holder (Right) | 1 |
| 30 | Safety Limit Tube | 1 |
| 32 | Safety Limit Tube Pin | 1 |

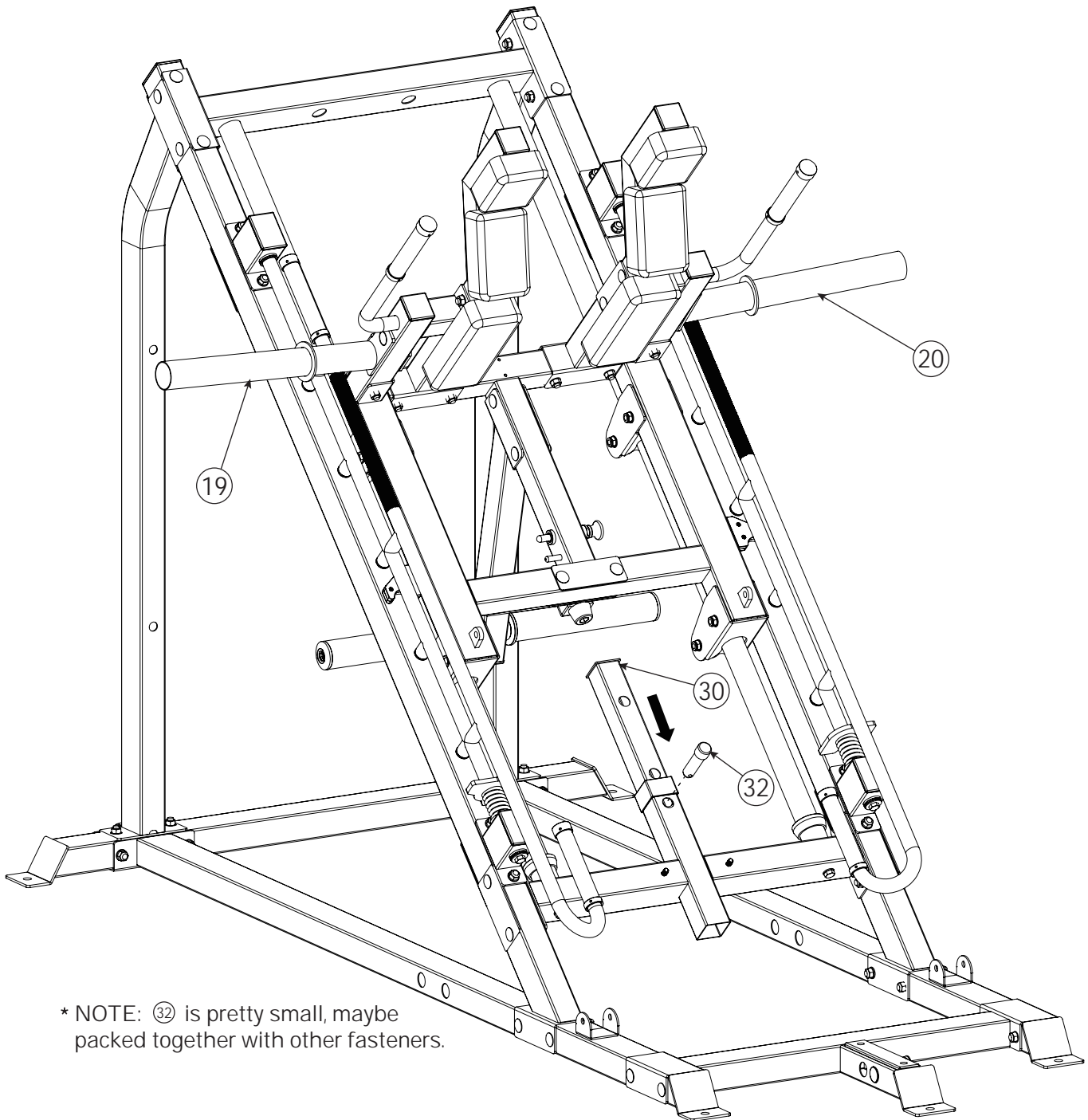

* NOTE: ③② is pretty small, maybe packed together with other fasteners.

ASSEMBLY AND ADJUSTMENT

STEP 17 (Two People Are Required.)

| NO. | DESCRIPTION | QUANTITY |
|-----|----------------------------------|----------|
| 15 | Leg Press Board | 1 |
| 16 | Leg Press Board Adjustment Piece | 1 |
| b | M10x70 Square Neck Bolt | 2 |
| e | M10x35 Hex Bolt | 2 |
| k | M10 Washer | 6 |
| m | M10 Nut | 4 |

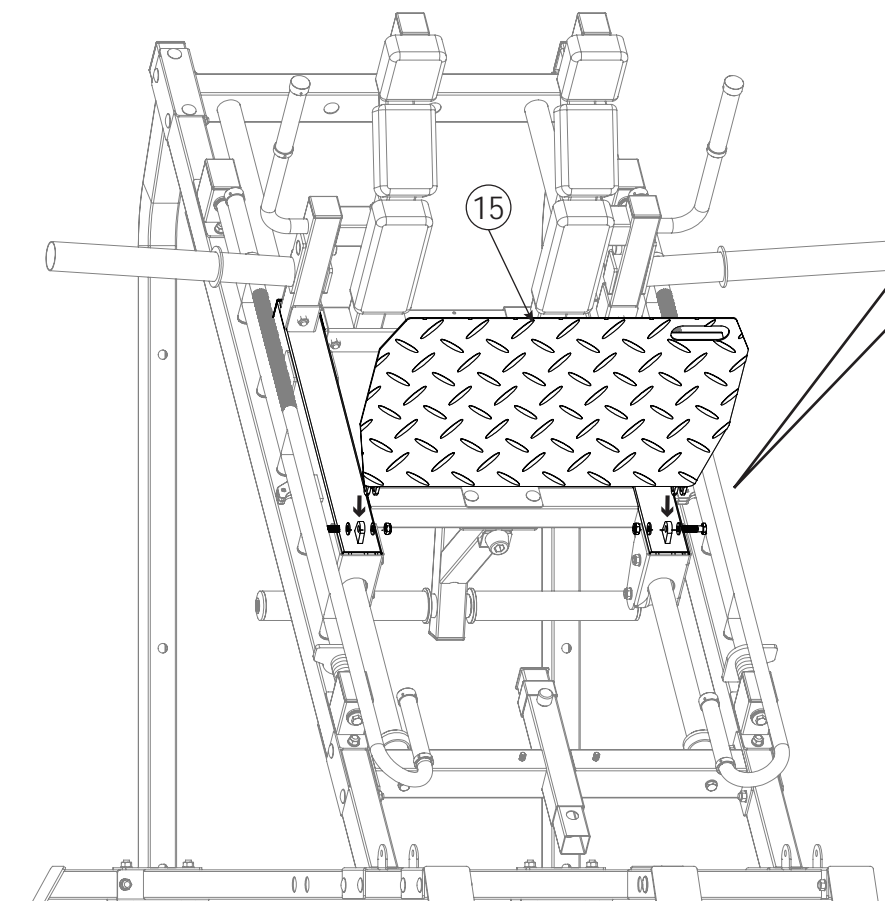
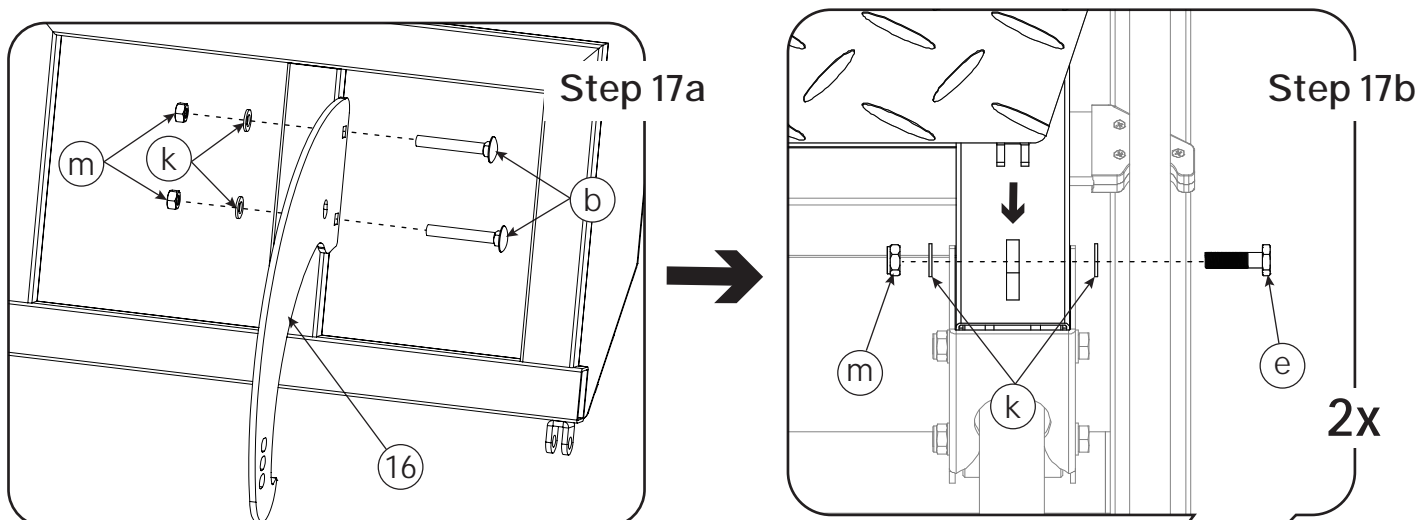

ASSEMBLY AND ADJUSTMENT

STEP 18 (Two People Are Required.)

| NO. | DESCRIPTION | QUANTITY |
|-----|----------------|----------|
| 27 | Seat Cushion | 1 |
| g | M8x85 Hex Bolt | 2 |
| l | M8 Washer | 2 |

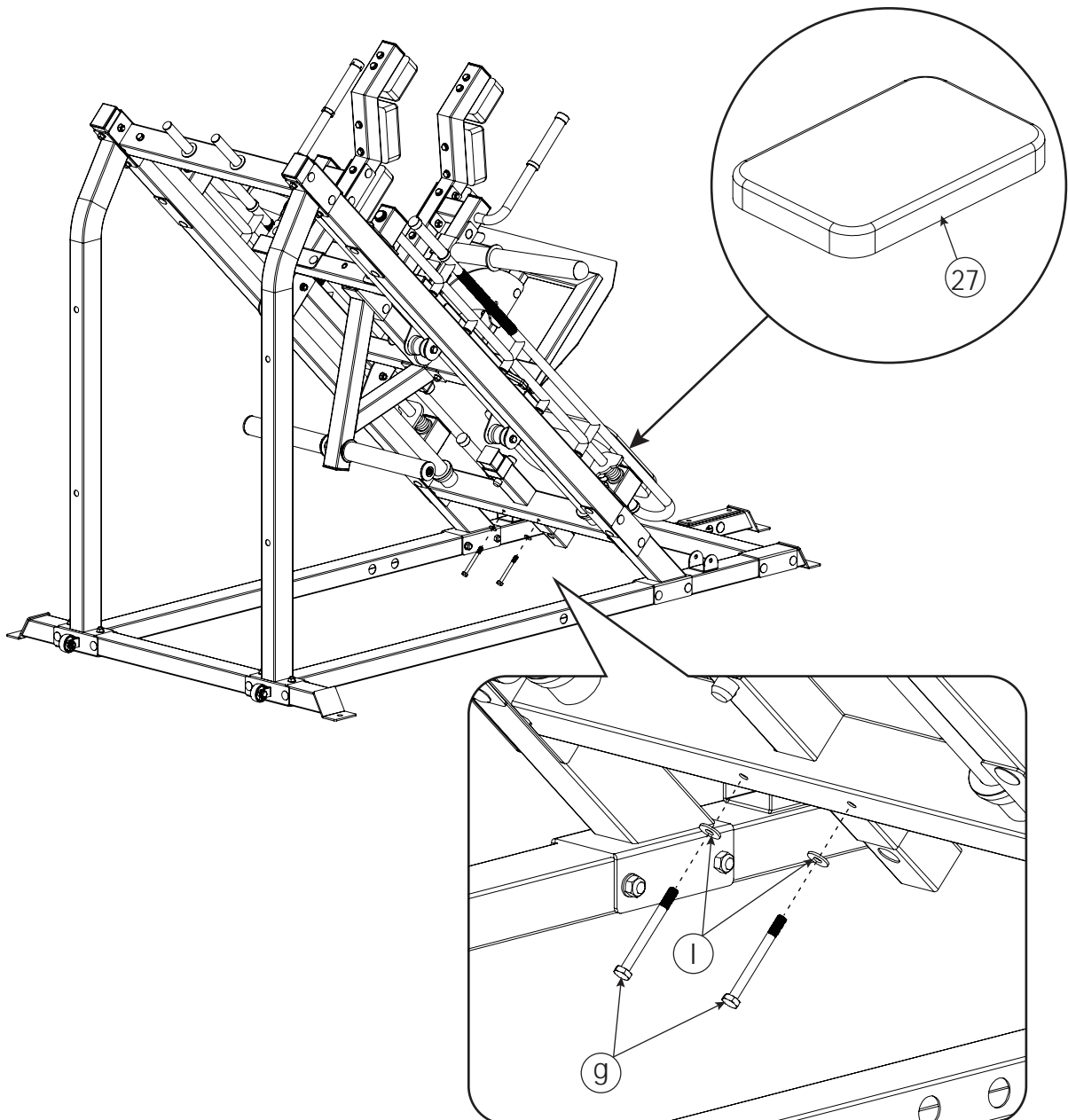

ASSEMBLY AND ADJUSTMENT

STEP 19 (Two People Are Required.)

| NO. | DESCRIPTION | QUANTITY |
|-----|--------------------------------|----------|
| 31 | Pin | 1 |
| 36 | Resistance Band Peg | 1 |
| 41 | Foot Plate Adjustment Piece | 2 |
| 42 | Foot Plate Adjustment Handrail | 1 |
| c | M10x80 Hex Bolt | 1 |
| k | M10 Washer | 2 |
| m | M10 Nut | 1 |

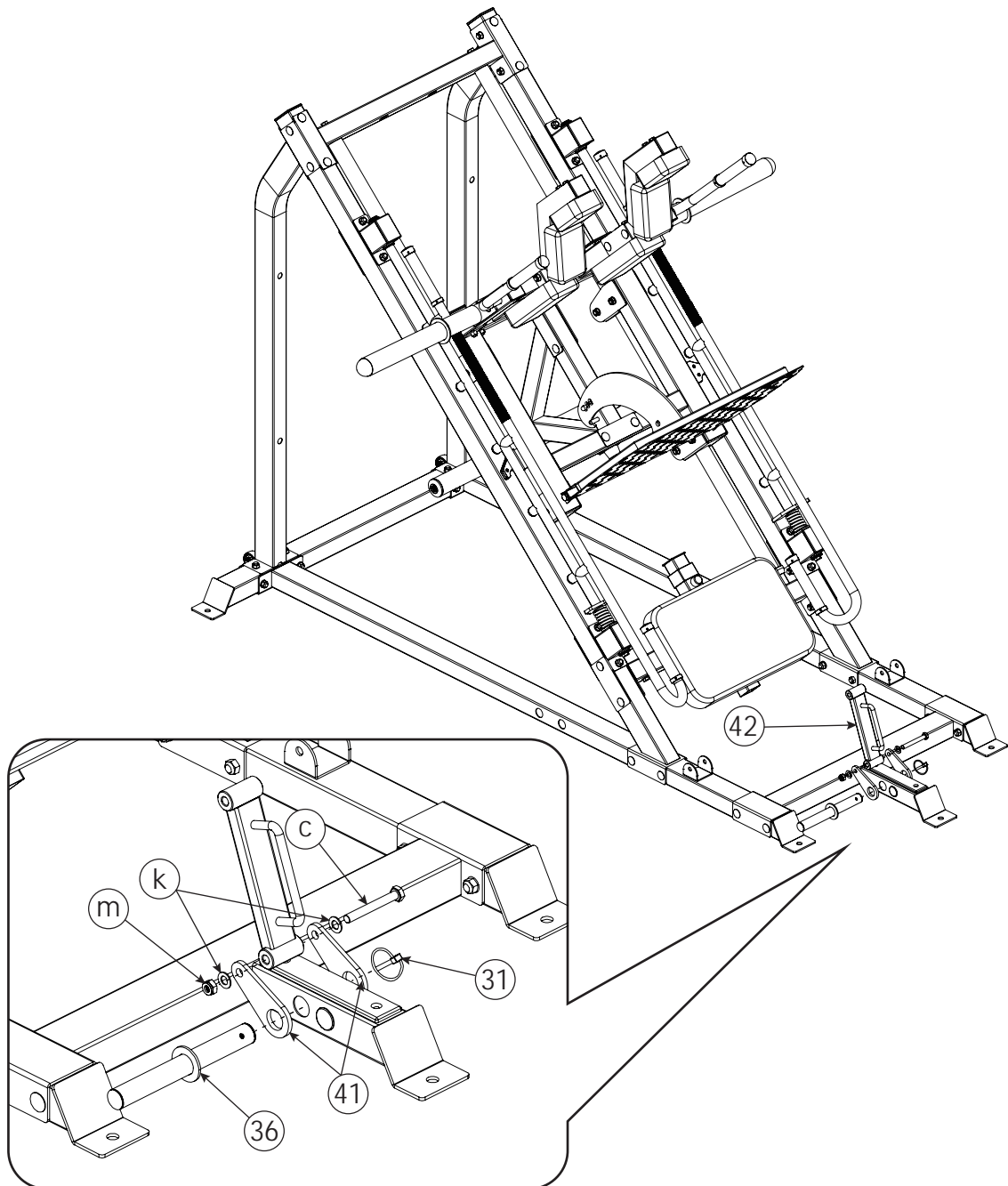

ASSEMBLY AND ADJUSTMENT

STEP 20 (Two People Are Required.)

| NO. | DESCRIPTION | QUANTITY |
|-----|-----------------|----------|
| 14 | Foot Plate | 1 |
| d | M10x70 Hex Bolt | 3 |
| k | M10 Washer | 6 |
| m | M10 Nut | 3 |

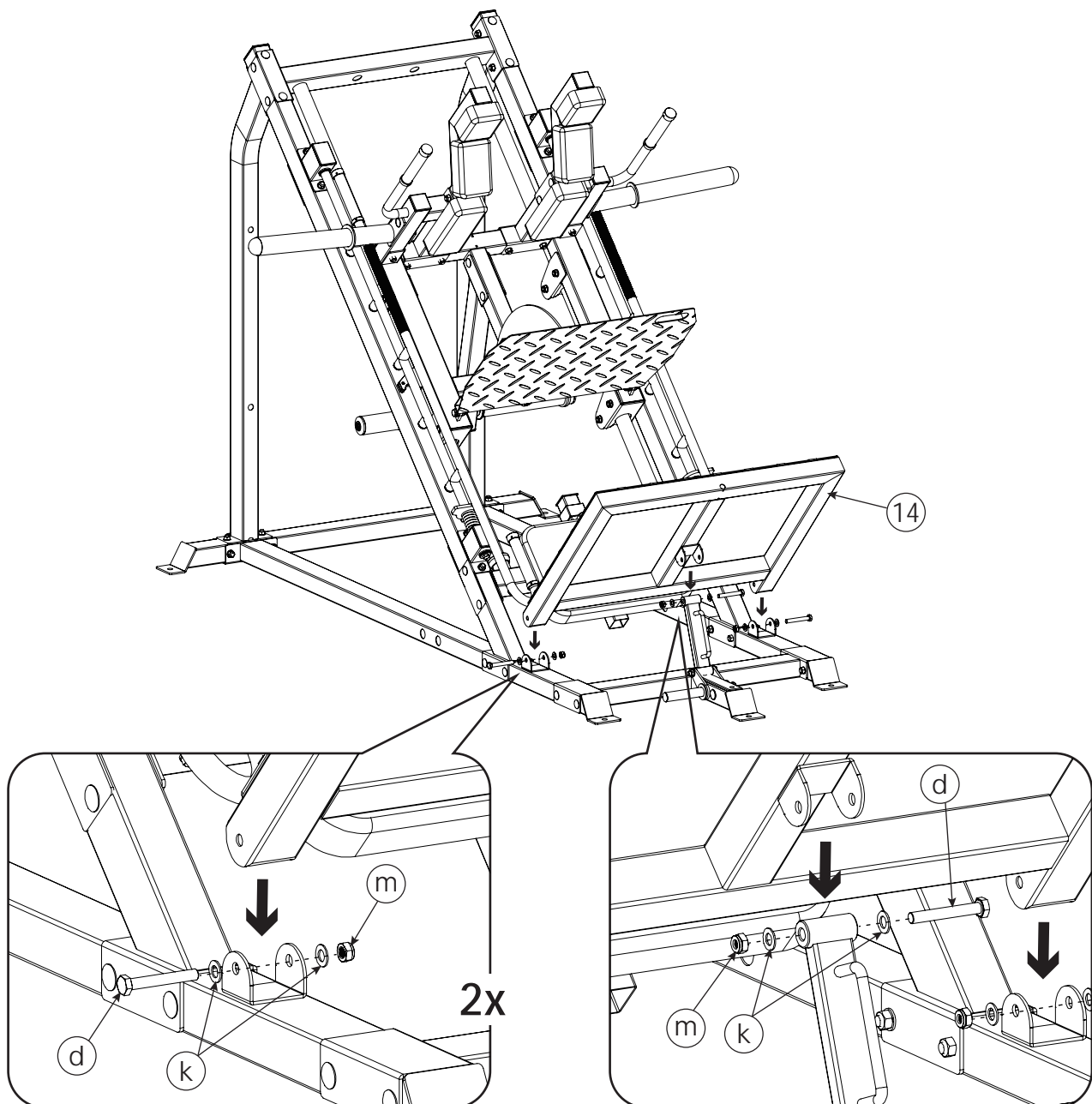

ASSEMBLY AND ADJUSTMENT

STEP 21 (Two People Are Required.)

| NO. | DESCRIPTION | QUANTITY |
|-----|-----------------------|----------|
| 33 | Plate Storage (Left) | 2 |
| 34 | Plate Storage (Right) | 2 |

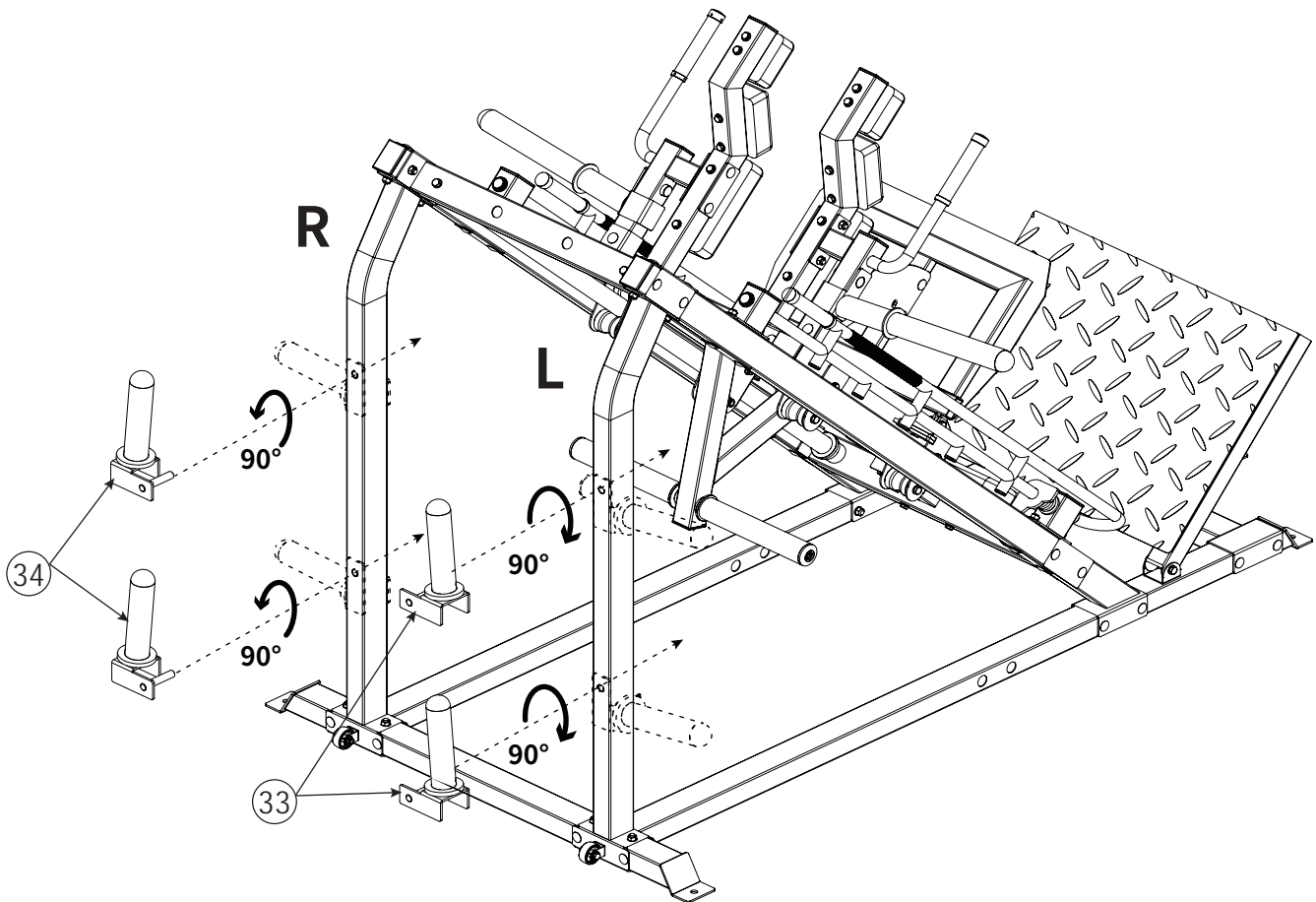

ASSEMBLY AND ADJUSTMENT

STEP 22 (Two People Are Required.)

| NO. | DESCRIPTION | QUANTITY |
|-----|---------------------|----------|
| 31 | Pin | 4 |
| 36 | Resistance Band Peg | 4 |

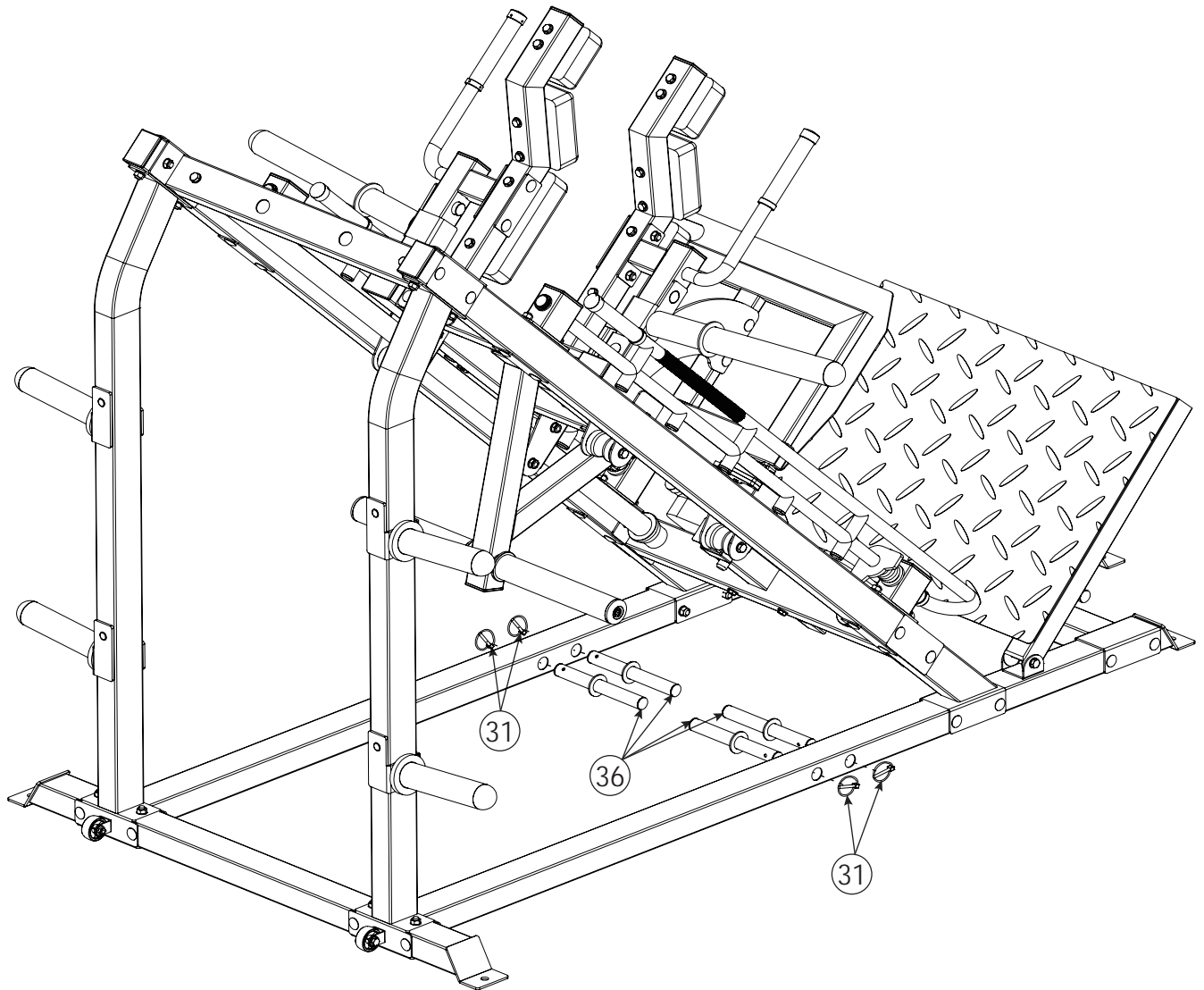

ASSEMBLY AND ADJUSTMENT

STEP 23 (Two People Are Required.)

| NO. | DESCRIPTION | QUANTITY |
|-----|---------------------|----------|
| 31 | Pin | 2 |
| 36 | Resistance Band Peg | 2 |

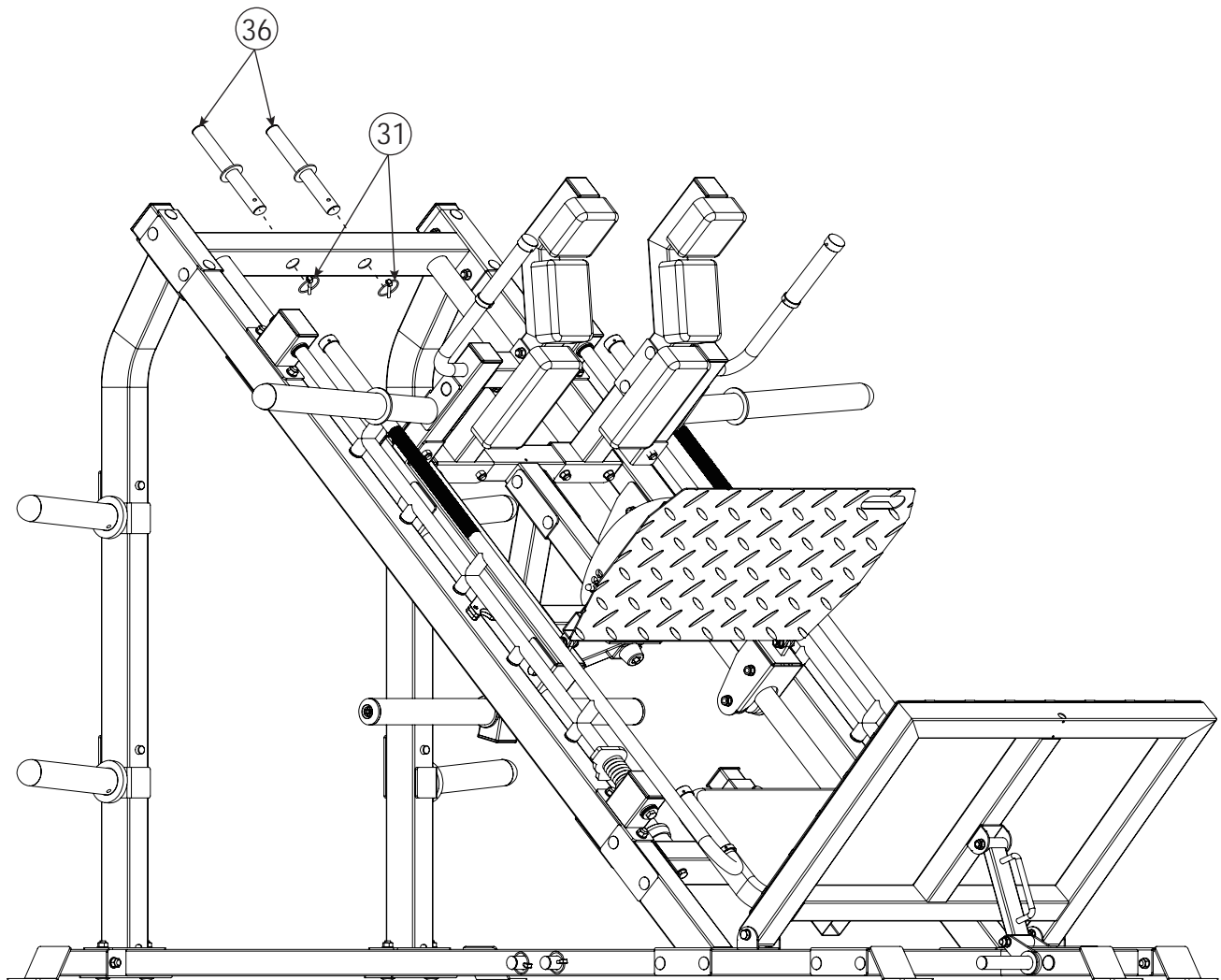

ASSEMBLY AND ADJUSTMENT

STEP 24 (Two People Are Required.)

| NO. | DESCRIPTION | QUANTITY |
|-----|---------------------------|----------|
| 23 | Back Cushion | 1 |
| 28 | Back Cushion Fixing Plate | 1 |
| 29 | Back Cushion Pin | 1 |
| i | M8x20 Hex Bolt | 2 |
| l | M8 Washer | 2 |

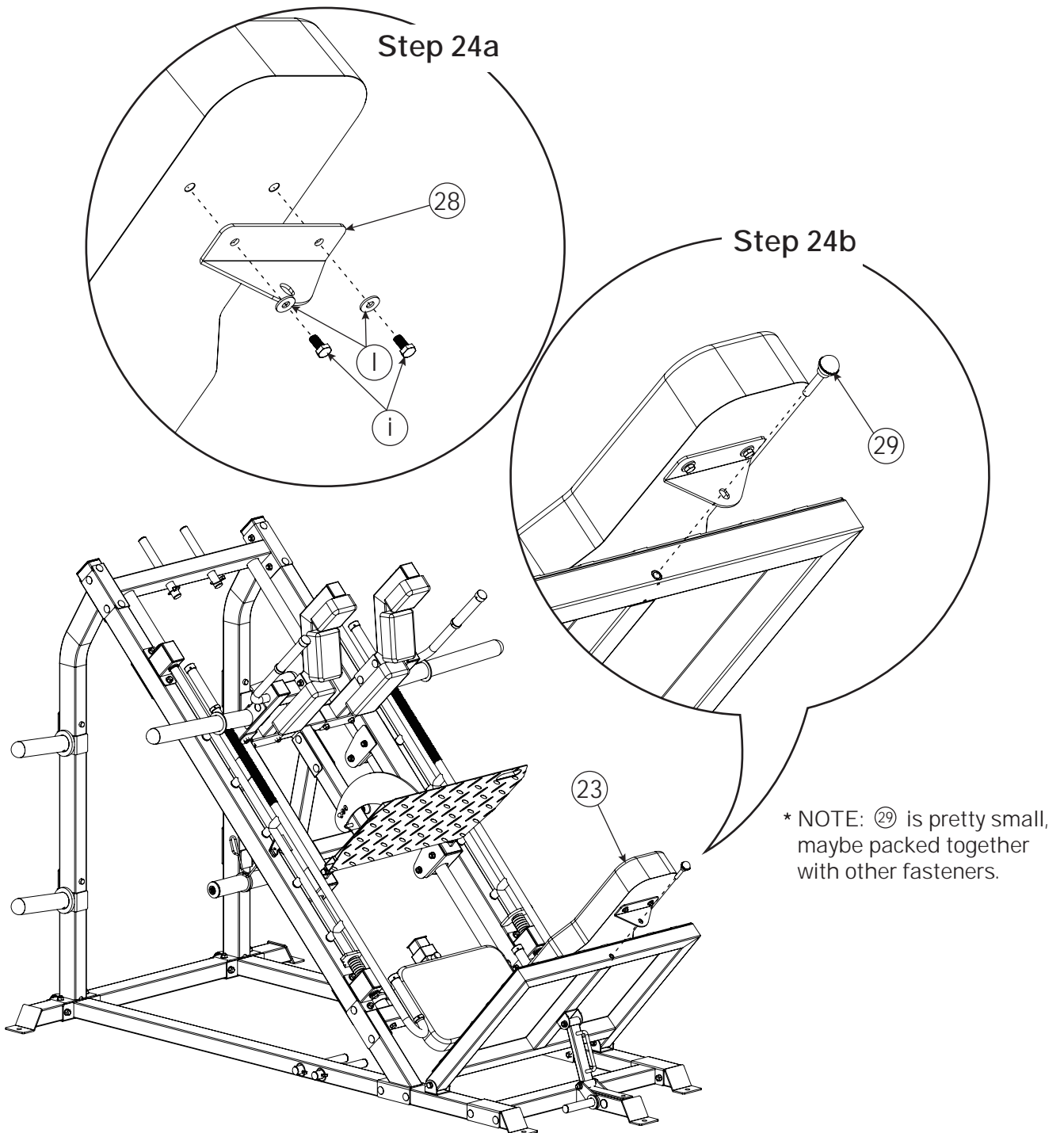

Congratulations!

You have assembled the Leg Press Machine!
Now, you can officially start leg strength training with RITFIT.

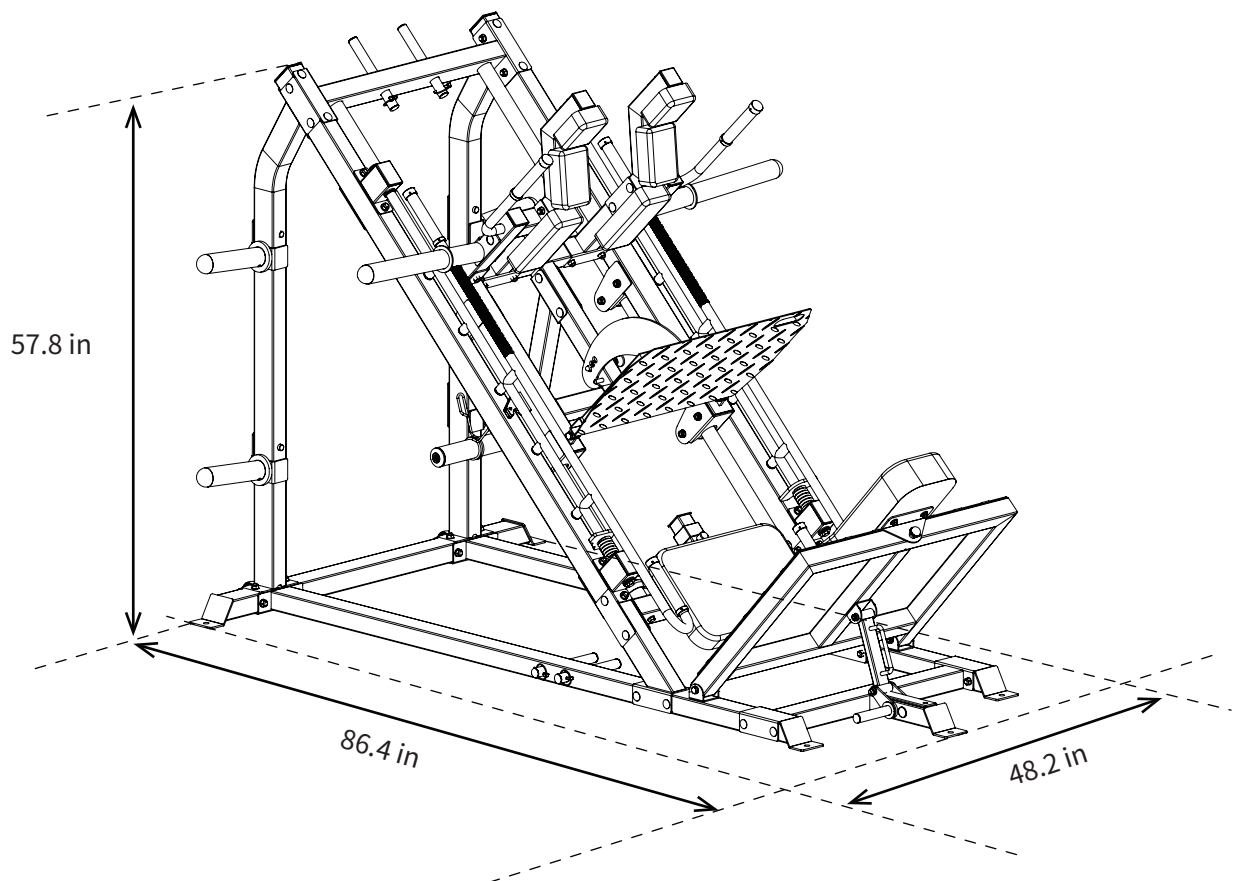

Don't mind if you have extra fasteners after installation, which can be used as future replacement parts.

RITFIT

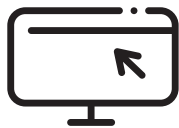

www.ritfitsports.com

SUBSCRIBE WEBSITE AND GET

- Free Exercise Ebook
- Lastest Updates



GOT A PROBLEM? GET IN TOUCH
support@ritfitsports.com

GET SOCIAL WITH US

