

RITFIT

MULTIFUNCTIONAL POWER CAGE BPC05



BPC05
Installation
Guide

Video
Tutorial

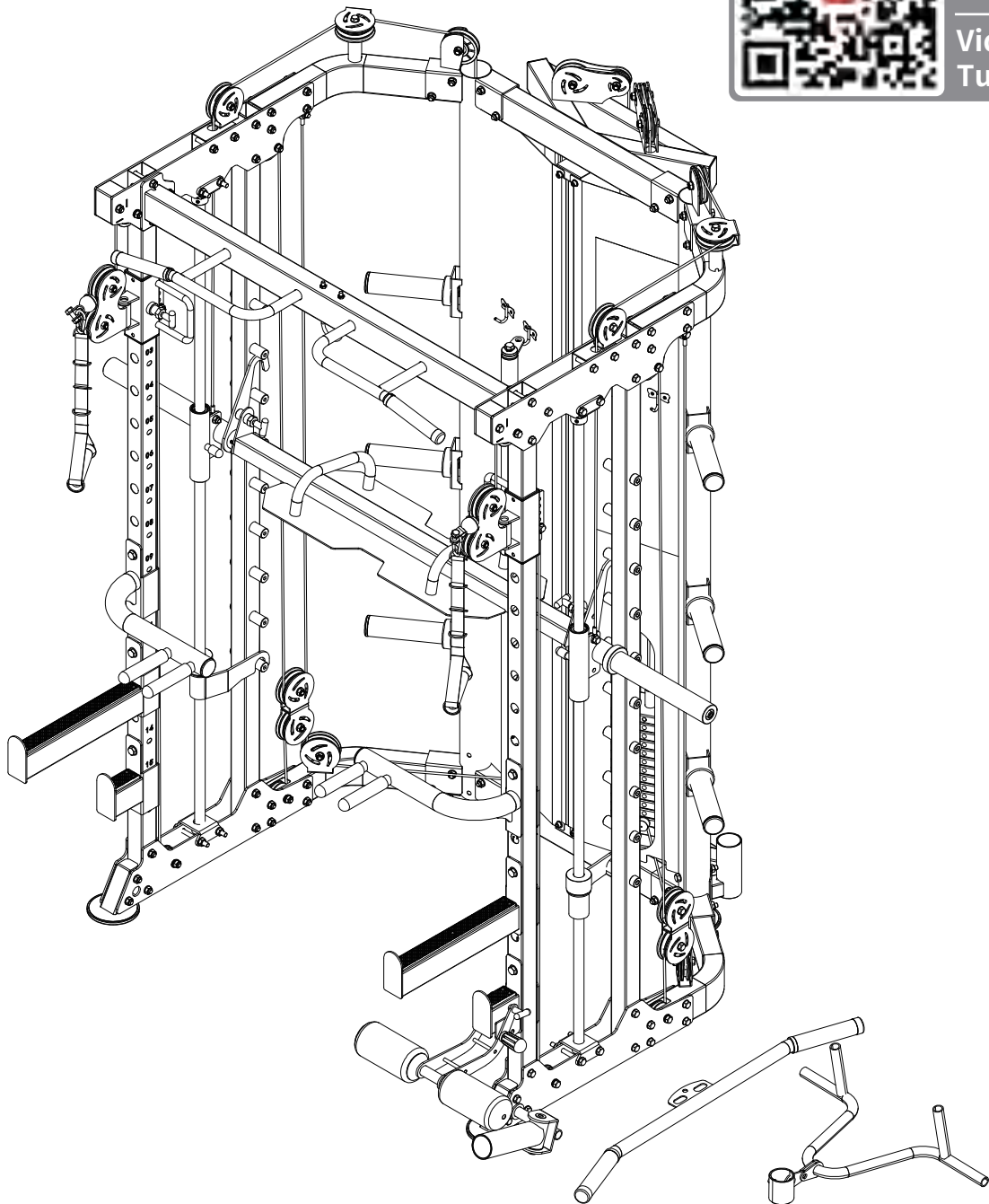

OWNER'S MANUAL & ASSEMBLY INSTRUCTIONS

SAFETY & PRECAUTIONS

IMPORTANT: READ ALL PRECAUTIONS CAREFULLY BEFORE USING THIS PRODUCT. RETAIN OWNER'S MANUAL FOR FUTURE REFERENCE.

- In the event should you find this product has either a defective or a missing part, do not use substitute parts or try to use the unit in an incomplete form. Please contact RITFIT for a replacement.
- Additional features on products may be added during seasonal production but may not be featured in line art diagrams at time of production. Changes of such will not affect the performance or assembly of the unit. If you would like further clarification during your assembly process please feel free to contact RITFIT for direction.
- This product has been designed for light commercial or home use only. Light commercial can be defined as a location with multiple users but not in a membership setting. Examples would be hotels, fire departments, high schools, etc. Commercial use would include, but not limited to, locations that accept membership for use of equipment.
- This exercise equipment was designed and built for optimum safety. However certain operator precautions apply whenever you operate a piece of exercise equipment. Please note the following safety procedures:
 1. Keep children and pets away from this equipment.
 2. Always inspect equipment prior to use to assure the structural integrity. Some parts may need occasional maintenance due to wear and tear.
 3. Lubricate moving parts as needed (depends on use but once a month is a good rule to follow).
 4. One person at a time should use this equipment unless otherwise designed for safety (example: spotter stand on some weight benches).
 5. If dizziness, nausea, chest pains, or any other abnormal symptoms are experienced while using this equipment, stop the workout at once. CONSULT A PHYSICIAN IMMEDIATELY.
 6. Always use this equipment on a level surface. Do not use outdoors or near water.
 7. Keep hands and feet away from any moving parts that are not intended to have body parts near them while in use.
 8. Do not insert any object into any openings unless object is supposed to be inserted into a particular place (such as a pin in a weight stack).
 9. Before using this equipment, always do stretching exercise to warm up.
 10. Use this equipment only for its intended use as described in manual.
 11. Always wear appropriate workout clothing and shoes when exercising. DO NOT WEAR ROBES OR OTHER CLOTHING THAT COULD BECOME CAUGHT IN THE EQUIPMENT.
 12. BEFORE BEGINNING ANY EXERCISE PROGRAM, CONSULT YOUR PHYSICIAN.
 13. If you have any question, please e-mail our customer service team at support@ritfitsports.com.

CARE AND MAINTENANCE

- Inspect and tighten all parts before using the equipment.
- The equipment can be cleaned using a damp cloth and mild non-abrasive detergent. DO NOT use solvents.
- Examine the equipment regularly for signs of damages or wear.
- Replace any defective components immediately and/or keep the equipment out of use until repair.
- Failure to examine regularly may affect the safety level of the equipment.

BEFORE YOU BEGIN

Thank you for selecting the versatile RITFIT® Multifunctional Power Cage. RITFIT® Multifunctional Power Cage is designed to be used with weight training system and the pulley system as well as your body weight to help you develop every major muscle group of the body.

For your benefit, read this manual carefully before using the Multifunctional Power Cage. If you have additional questions, please email our Customer Service Department at support@ritfitsports.com. To help us assist you, please note the product model number and serial number before calling. The model number is BPC05.

BEFORE READING FURTHER, PLEASE REVIEW THE DRAWING BELOW AND FAMILIARIZE YOURSELF WITH THE PARTS THAT ARE LABELED.

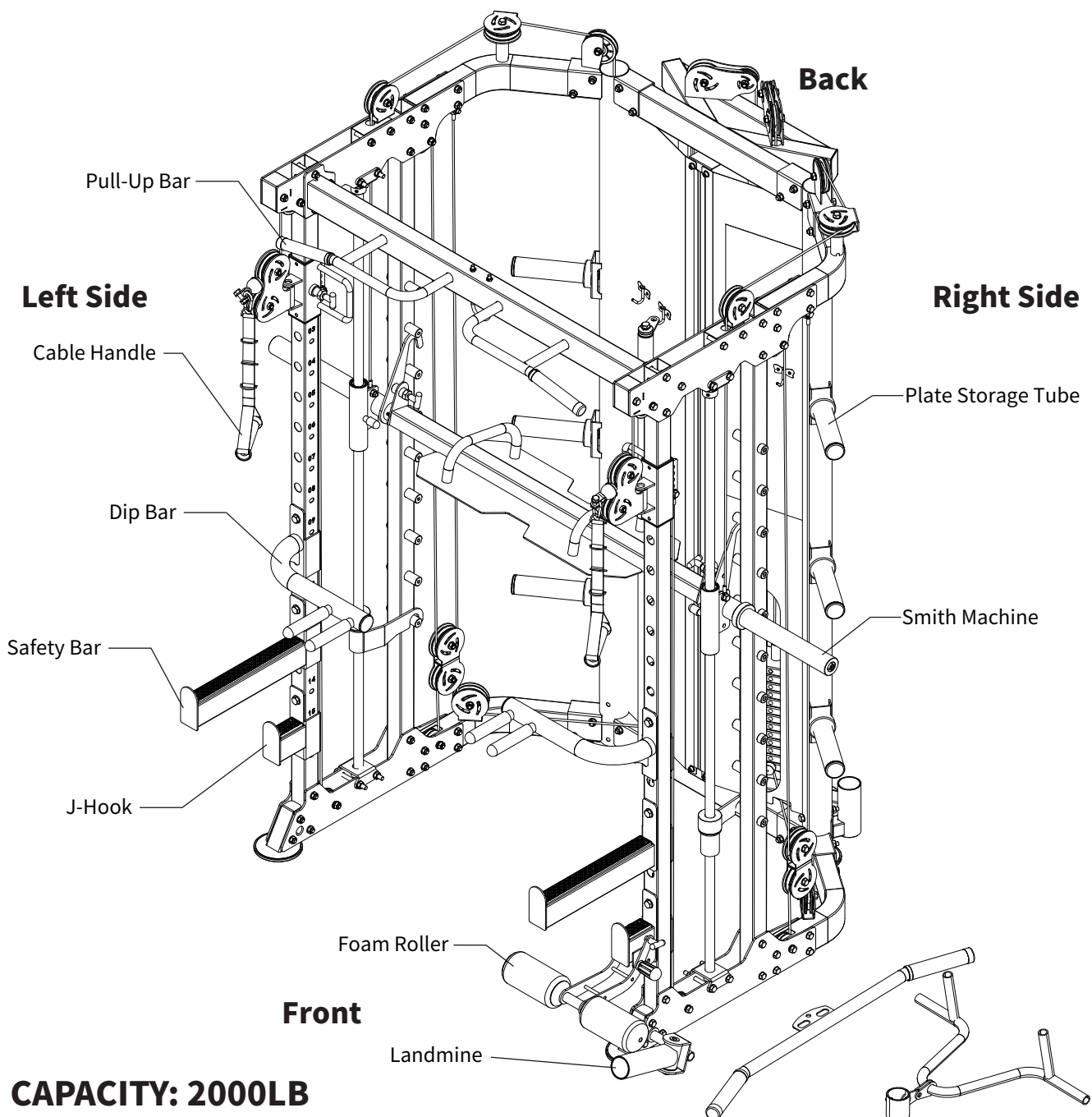

PARTS LIST

FASTENER AND TOOLS

NO.	DESCRIPTION	QUANTITY
a	M10x90 Hex Bolt	10
b	M10x80 Hex Bolt	14
c	M10x75 Hex Bolt	54
d	M10x45 Hex Bolt	22
e	M6x15 Hexagon Screw	10
f	M10x25 Hex Bolt (Pre-installed)	14
g	M10 Nut	104
h	M10 Washer	218
i	M6 Washer	10
j	M10x20 Hexagon Socket Bolt (Pre-installed)	2
k	Big Washer (Pre-installed)	2

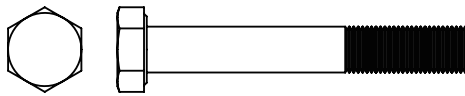

(a) M10x90 Hex Bolt
10x

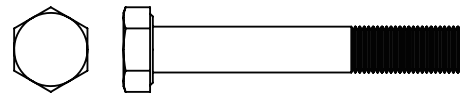

(b) M10x80 Hex Bolt
14x

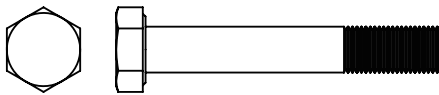

(c) M10x75 Hex Bolt
54x

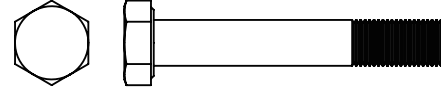

(d) M10x45 Hex Bolt
22x

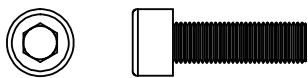

(e) M6x15 Hexagon Screw
10x

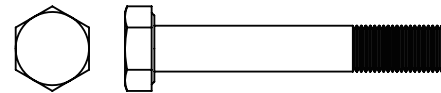

(f) M10x25 Hex Bolt (Pre-installed)
14x



(g) M10 Nut
104x



(h) M10 Washer
218x



(i) M6 Washer
10x

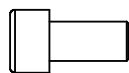

(j) M10x20 Hexagon Socket Bolt
2x

(Pre-installed, inside the Barbell (29))



(k) Big Washer
2x

(Pre-installed, inside the Barbell (29))

PARTS LIST

• PACKED IN THE BOX

NO.	DESCRIPTION	QUANTITY
1	Back Upright Frame (Left)	1
2	Back Upright Frame (Right)	1
3	Top Beam	1
4	Bottom Beam	1
5	Top Bent Frame (Left)	1
6	Top Bent Frame (Right)	1
7	Bottom Bent Frame (Left)	1
8	Bottom Bent Frame (Right)	1
9	Top Bracket	4
10	Bottom Bracket	4
11	Smith Positioning Upright Frame	2

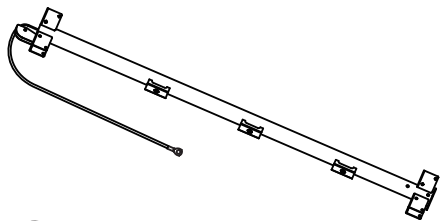

① Back Upright Frame (Left)
1x

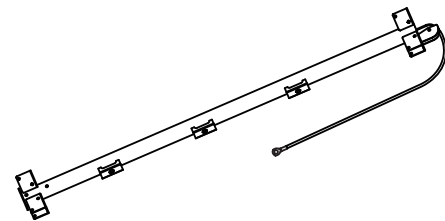

② Back Upright Frame (Right)
1x

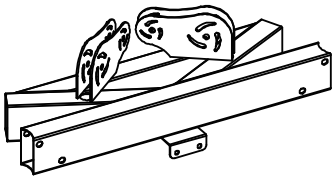

③ Top Beam
1x

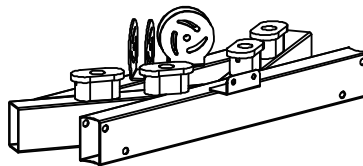

④ Bottom Beam
1x

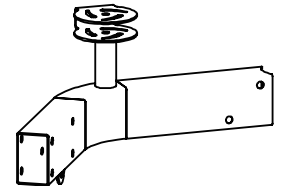

⑤ Top Bent Frame (Left)
1x

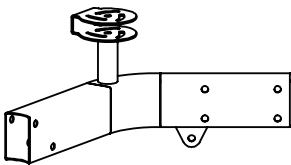

⑥ Top Bent Frame (Right)
1x

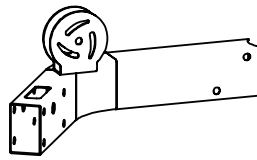

⑦ Bottom Bent Frame (Left)
1x

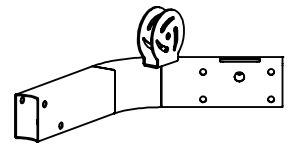

⑧ Bottom Bent Frame (Right)
1x

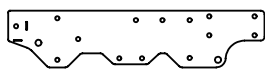

⑨ Top Bracket
4x

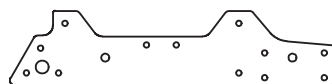

⑩ Bottom Bracket
4x

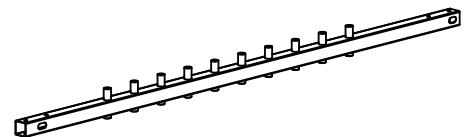

⑪ Smith Positioning Upright Frame
2x

PARTS LIST

• PACKED IN THE BOX

NO.	DESCRIPTION	QUANTITY
12	Single Pulley Cover (Left)	1
13	Single Pulley Cover (Right)	1
14	Slider Upright Frame (Left)	1
15	Slider Upright Frame (Right)	1
16	Slider (Left)	1
17	Slider (Right)	1
18	Bracket-Frame Connector	2
19	Foot Cap	2
20	Pull-up Bar	1
21	Solid Barbell Guiding Rod	2
22	Barbell Safety Support Hook (Left)	1
23	Barbell Safety Support Hook (Right)	1



⑫ Single Pulley Cover (Left)
1x



⑬ Single Pulley Cover (Right)
1x

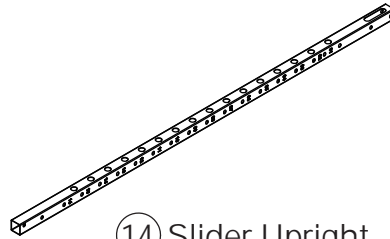

⑭ Slider Upright Frame (Left)
1x

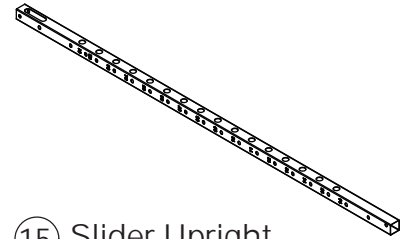

⑮ Slider Upright Frame (Right)
1x

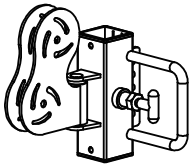

⑯ Slider (Left)
1x

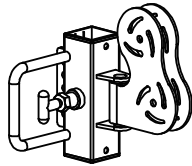

⑰ Slider (Right)
1x



⑱ Bracket-Frame Connector
2x



⑲ Foot Cap
2x

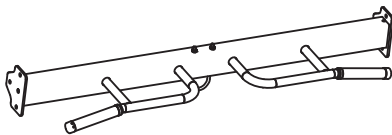

⑳ Pull-up Bar
1x



㉑ Solid Barbell Guiding Rod
2x



㉒ Barbell Safety Support Hook (Left)
1x



㉓ Barbell Safety Support Hook (Right)
1x

PARTS LIST

• PACKED IN THE BOX

NO.	DESCRIPTION	QUANTITY
24	Barbell Guiding Rod Bottom Seat	2
25	Barbell Positioning Tube	2
26	Solid Barbell Guiding Rod Bottom Pad	2
27	Solid Barbell Guiding Rod Top Cup	2
28	Barbell Guiding Rod Top Seat	2
29	Barbell	1
30	Barbell Positioning Hook (Left)	1
31	Barbell Positioning Hook (Right)	1
32	Hoist	2
33	Top Weight Stack	2
34	Weight Stack	24
35	Weight Stack Pin	2
36	Weight Stack Plastic Sleeve	4



②④ Barbell Guiding Rod Bottom Seat
2x

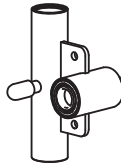

②⑤ Barbell Positioning Tube
2x

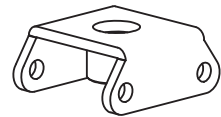

②⑥ Solid Barbell Guiding Rod Bottom Pad
2x



②⑦ Solid Barbell Guiding Rod Top Cup
2x



②⑧ Barbell Guiding Rod Top Seat
2x

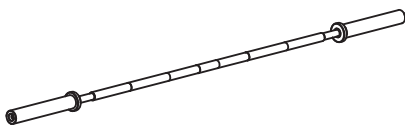

②⑨ Barbell
1x



③⑩ Barbell Positioning Hook (Left)
1x



③⑪ Barbell Positioning Hook (Right)
1x



③⑫ Hoist
2x

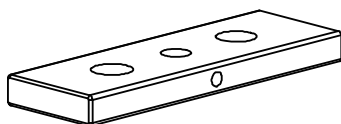

③⑬ Top Weight Stack
2x

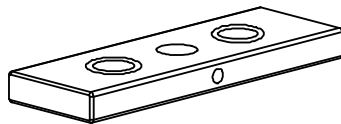

③⑭ Weight Stack
24x



③⑮ Weight Stack Pin
2x



③⑯ Weight Stack Plastic Sleeve
4x

PARTS LIST

• PACKED IN THE BOX

NO	DESCRIPTION	QUANTITY
37	Hollow Pulley System Guiding Rod	4
38	Weight Stack Bottom Pad	4
39	Hollow Rod Top Pads (Pre-installed)	1
40	Pulley B	24
41	Cable B (Pre-installed)	2
42	Pulley Peg	16
43	Double Pulley Cover	2
44	Cable C	2
45	Pulley A	6
46	Cable A	2
47	Cover	2
48	Poster	1
49	Hook	4



③⑦ Hollow Pulley System Guiding Rod
4x



③⑧ Weight Stack Bottom Pad
4x

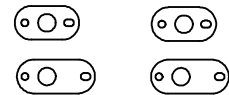

③⑨ Hollow Rod Top Pads
1x
(Pre-installed, on the Top Beam③)



④⑩ Pulley B
24x

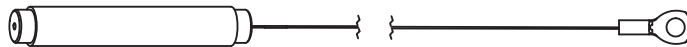

④① Cable B
2x
(Pre-installed, inside the Back Upright Frame ① & ②)



④② Pulley Peg
16x



④③ Double Pulley Cover
2x



④④ Cable C
2x



④⑤ Pulley A
6x



④⑥ Cable A
2x

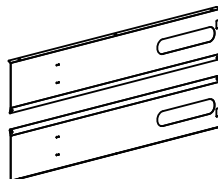

④⑦ Cover
2x

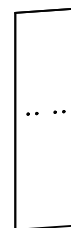

④⑧ Poster
1x

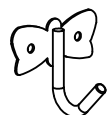

④⑨ Hook
4x

PARTS LIST

· PACKED IN THE BOX

NO.	DESCRIPTION	QUANTITY
50	Cover Connector	1
51	Plate Storage Tube	6
52	Barbell Storage	1
53	Landmine Attachment	1
54	Adjustable Pin	1
55	Leg Press Attachment	1
56	Dip Bars Set	1
57	Safety Bars Set	1
58	J-Hooks Set	1
59	Foam Roller Attachment	1
60	Lat Bar	1
61	Multi-grip Row Handle Set	1

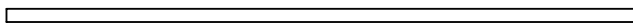

⑤① Cover Connector
1x

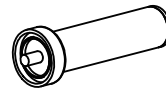

⑤② Plate Storage Tube
6x



⑤③ Barbell Storage
1x

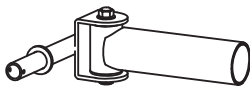

⑤④ Landmine Attachment
1x



⑤⑤ Adjustable Pin
1x

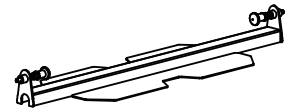

⑤⑥ Leg Press Attachment
1x



⑤⑦ Dip Bars Set
1x

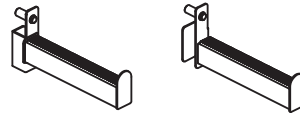

⑤⑧ Safety Bars Set
1x

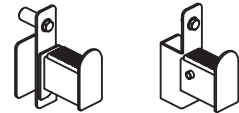

⑤⑨ J-Hooks Set
1x

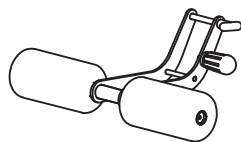

⑥① Foam Roller Attachment
1x

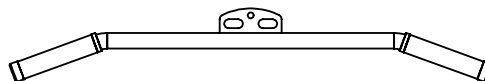

⑥② Lat Bar
1x

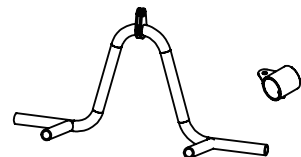

⑥③ Multi-grip Row Handle Set
1x

PARTS LIST

· PACKED IN THE BOX

NO.	DESCRIPTION	QUANTITY
62	Foot Pad	4
63	Yellow Pin	2
64	M4 Bolt	8
65	M4 Nut	8
66	Pulley Handle	2
67	Collar	2
68	Carabiner	3
69	Silicone Oil	1
70	Open-ended Wrench	2
71	Allen Key	1

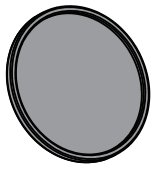

⑥② Foot Pad
4x

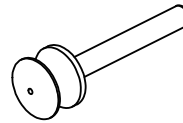

⑥③ Yellow Pin
2x

(You can use it to adjust the number of Weight Stacks ③④)

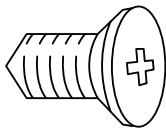

⑥④ M4 Bolt
8x

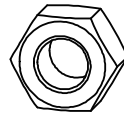

⑥⑤ M4 Nut
8x



⑥⑥ Pulley Handle
2x

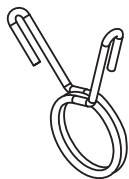

⑥⑦ Collar
2x

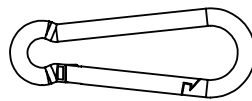

⑥⑧ Carabiner
3x



⑥⑨ Silicone Oil
1x

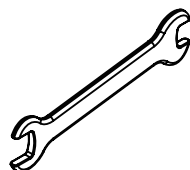

⑦⑦ Open-ended Wrench
2x



⑦① Allen Key
1x

ASSEMBLY AND ADJUSTMENT

STEP 1 (Two People Are Required.)

NO.	DESCRIPTION	QUANTITY
1	Back Upright Frame (Left)	1
2	Back Upright Frame (Right)	1
3	Top Beam	1
4	Bottom Beam	1
5	Top Bent Frame (Left)	1
6	Top Bent Frame (Right)	1
7	Bottom Bent Frame (Left)	1
8	Bottom Bent Frame (Right)	1
c	M10x75 Hex Bolt	16
g	M10 Nut	16
h	M10 Washer	32

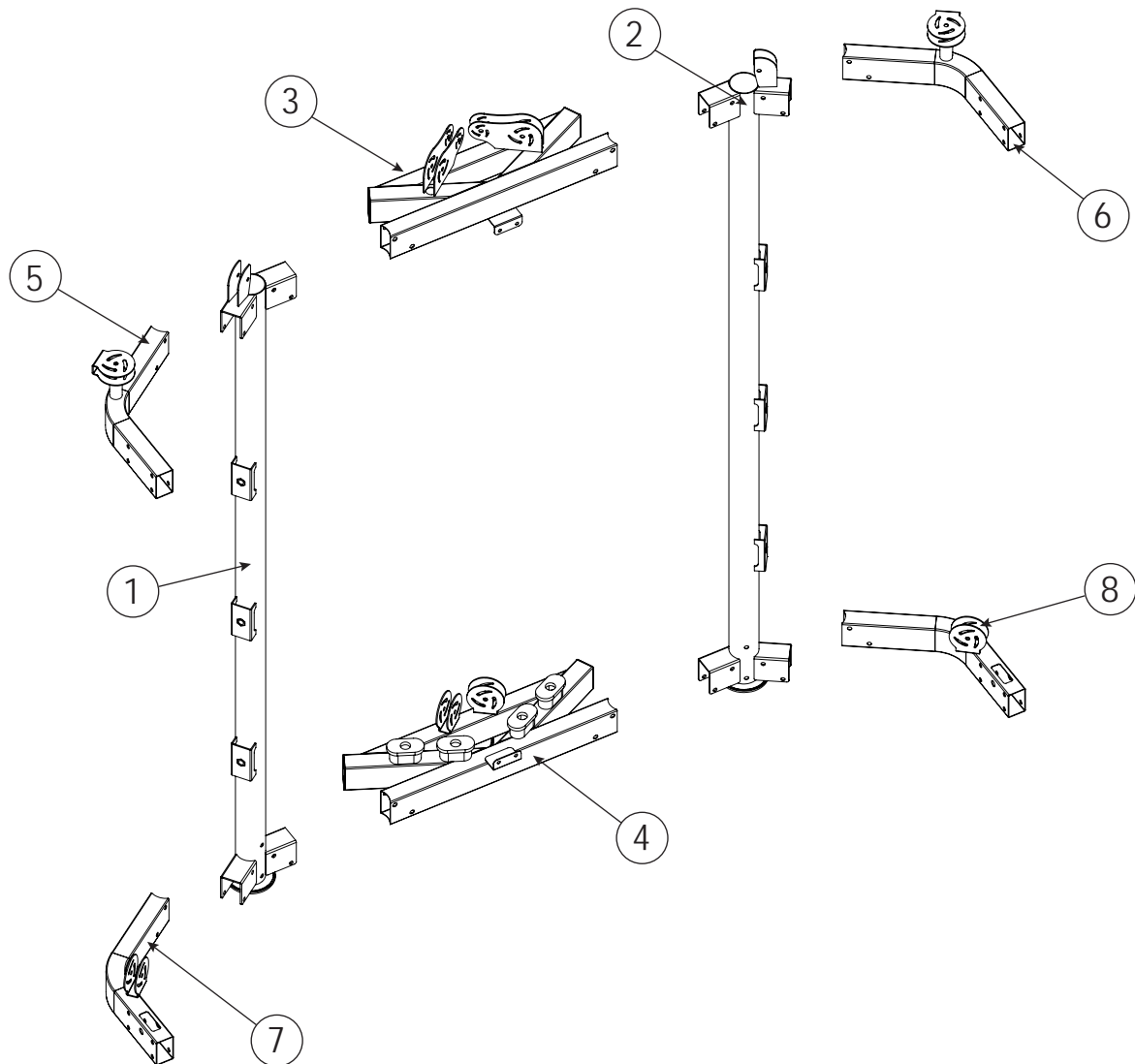

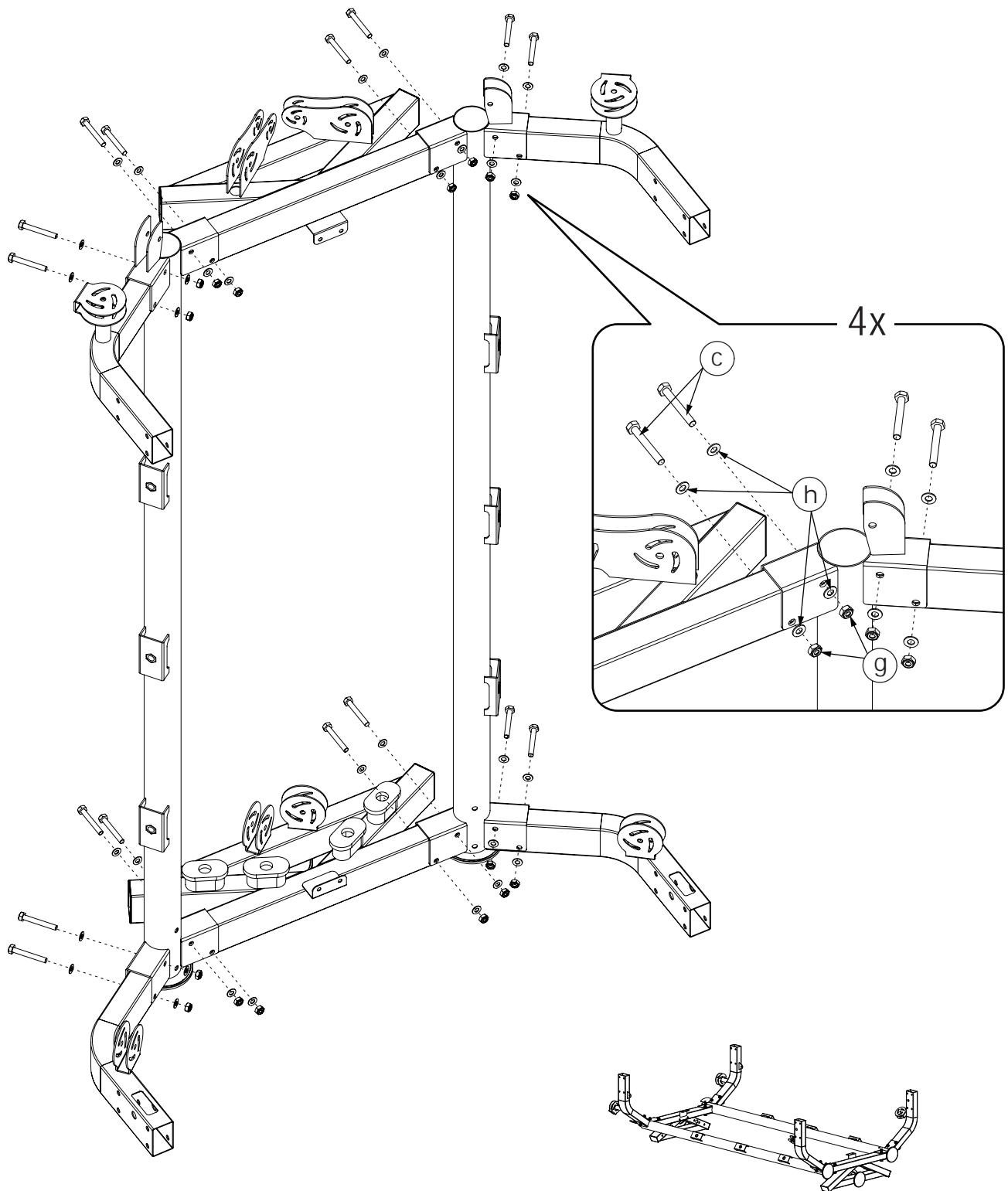

* Kindly Reminder:
 We recommend first placing the BPC05 on the ground when assembling it from Step 1 to Step 3, and then standing it upright from Step 4 (pay attention to avoid accidents such as hitting selves or scratching the ground).

STEP 2-1 (Two People Are Required.)

NO.	DESCRIPTION	QUANTITY
9	Top Bracket	2
10	Bottom Bracket	2
11	Smith Positioning Upright Frame	1
12	Single Pulley Cover (Left)	1
14	Slider Upright Frame (Left)	1
16	Slider (Left)	1
18	Bracket-Frame Connector	1
19	Foot Cap	1
40	Pulley B	2
c	M10x75 Hex Bolt	19
d	M10x45 Hex Bolt	2
g	M10 Nut	21
h	M10 Washer	42

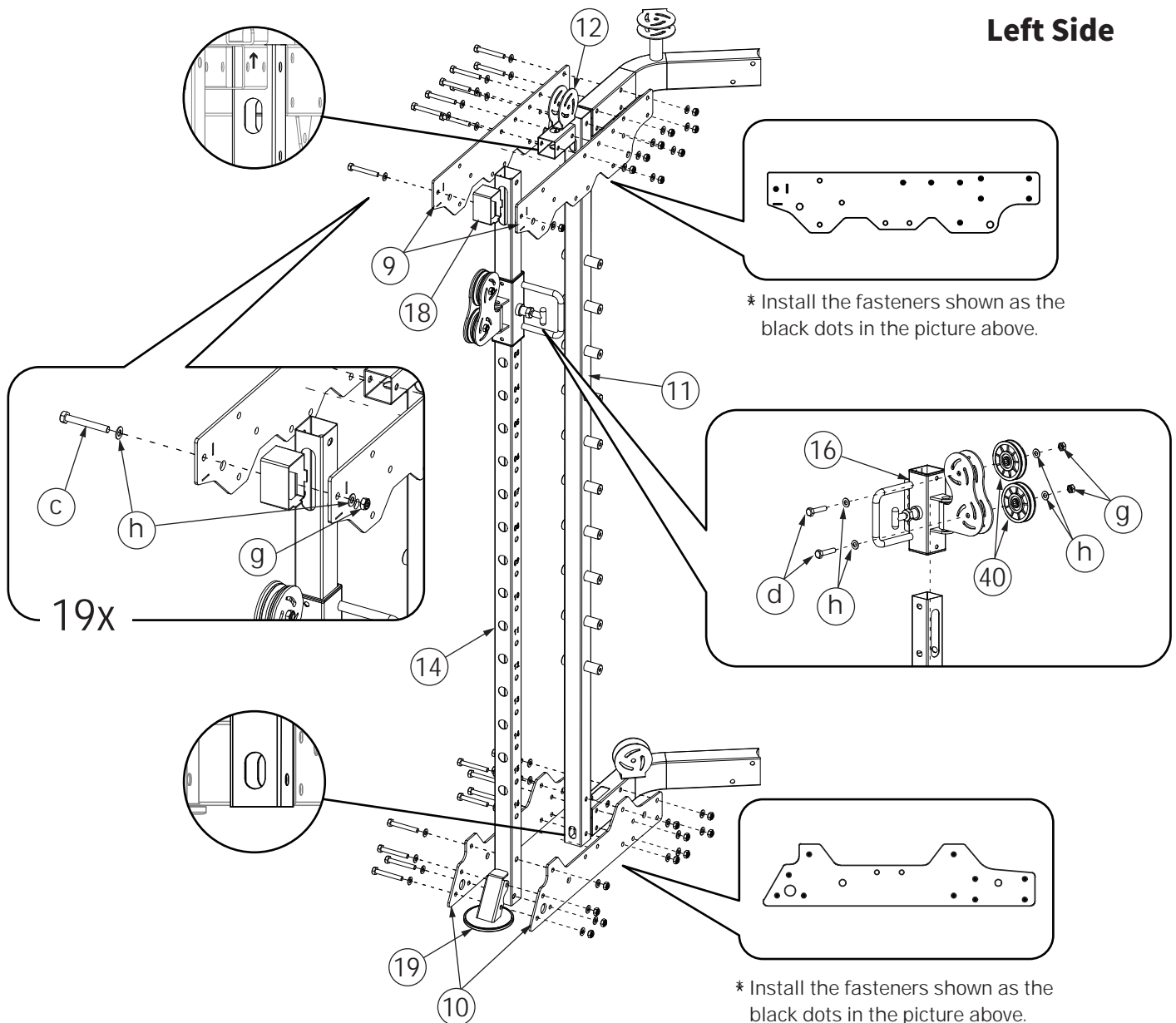

STEP 2-2 (Two People Are Required.)

NO.	DESCRIPTION	QUANTITY
9	Top Bracket	2
10	Bottom Bracket	2
11	Smith Positioning Upright Frame	1
13	Single Pulley Cover (Right)	1
15	Slider Upright Frame (Right)	1
17	Slider (Right)	1
18	Bracket-Frame Connector	1
19	Foot Cap	1
40	Pulley B	2
c	M10x75 Hex Bolt	19
d	M10x45 Hex Bolt	2
g	M10 Nut	21
h	M10 Washer	42

Right Side

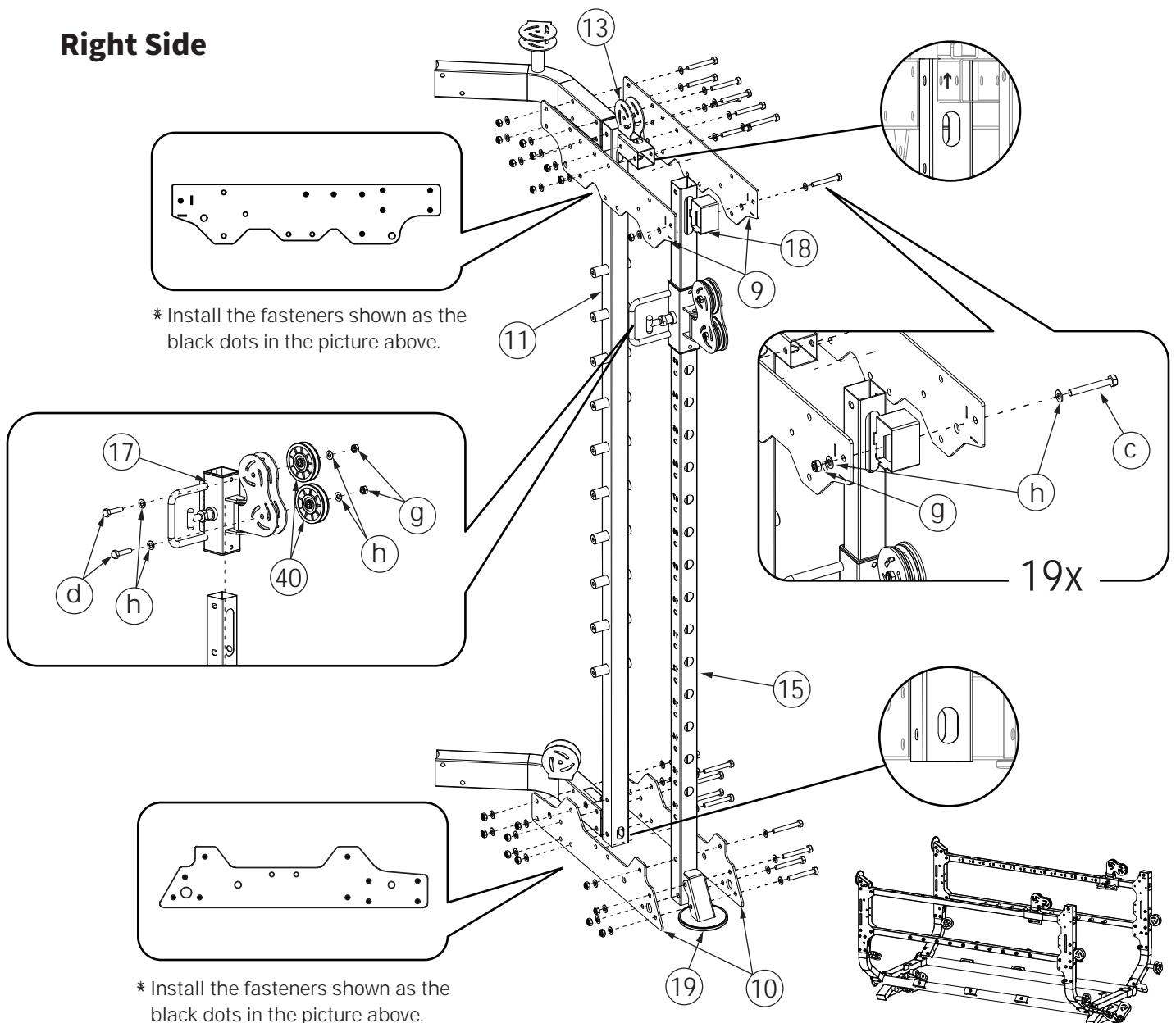

STEP 3-1 (Two People Are Required.)

NO.	DESCRIPTION	QUANTITY
20	Pull-up Bar	1
b	M10x80 Hex Bolt	6
g	M10 Nut	6
h	M10 Washer	12

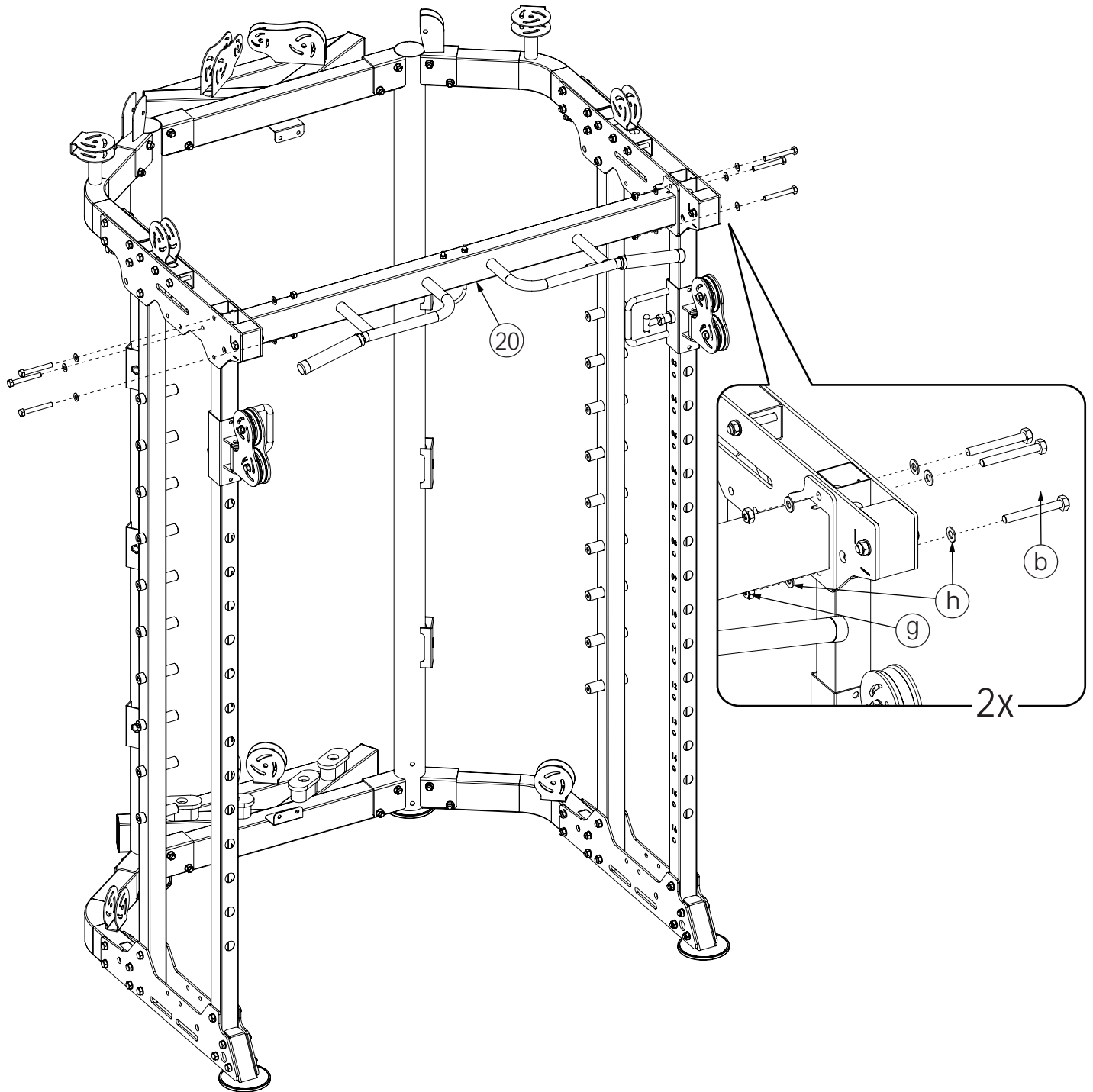

STEP 3-2 (Two People Are Required.)

NO.	DESCRIPTION	QUANTITY
62	Foot Pad	4

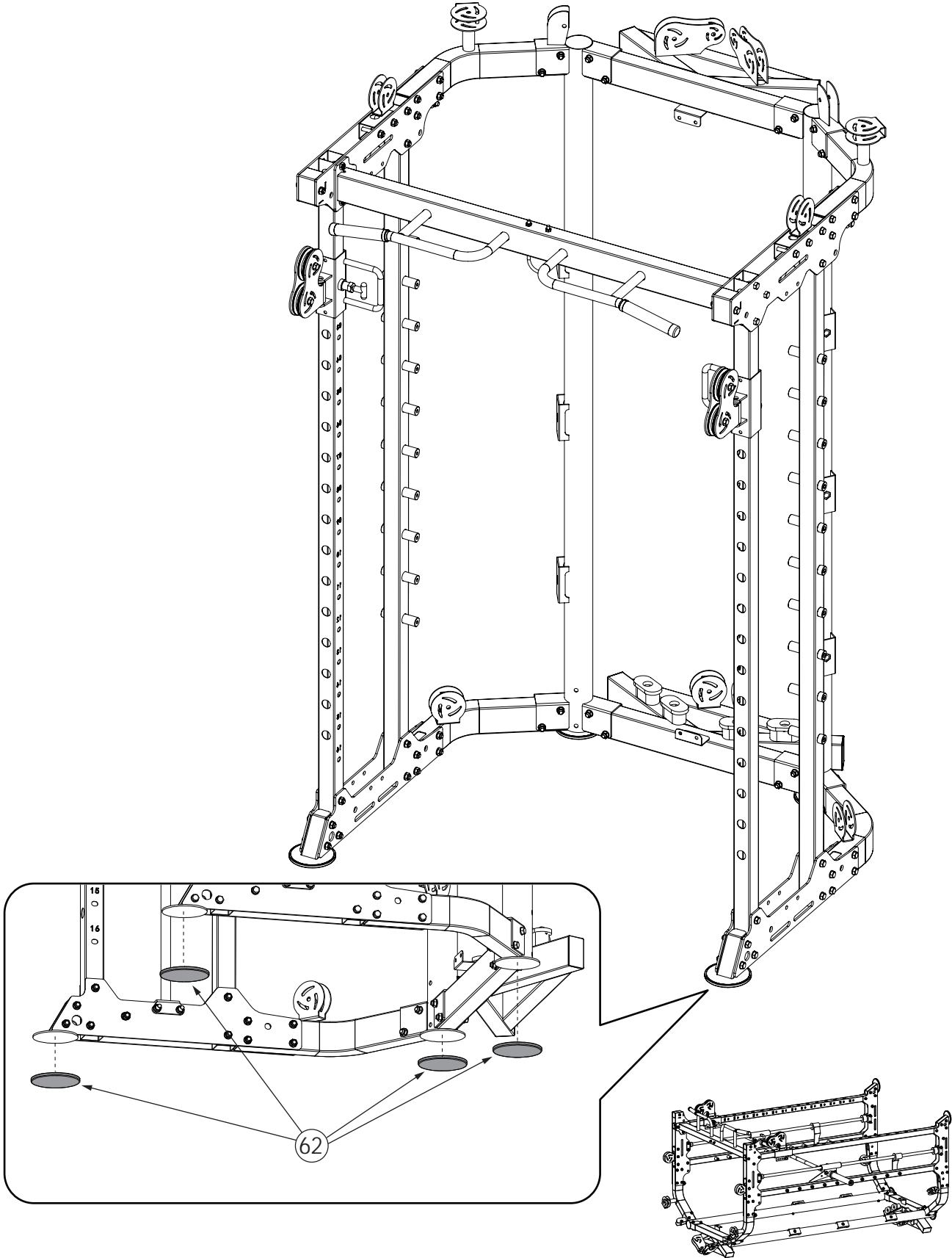

STEP 4 (Two People Are Required.)

NO.	DESCRIPTION	QUANTITY
21	Solid Barbell Guiding Rod	2
22	Barbell Safety Support Hook (Left)	1
23	Barbell Safety Support Hook (Right)	1
24	Barbell Guiding Rod Bottom Seat	2
25	Barbell Positioning Tube	2
26	Solid Barbell Guiding Rod Bottom Pad	2
27	Solid Barbell Guiding Rod Top Cup	2
28	Barbell Guiding Rod Top Seat	2
29	Barbell	1
30	Barbell Positioning Hook (Left)	1
31	Barbell Positioning Hook (Right)	1
a	M10x90 Hex Bolt	8
g	M10 Nut	8
h	M10 Washer	16
j	M10x20 Hexagon Socket Bolt	2
k	Big Washer	2

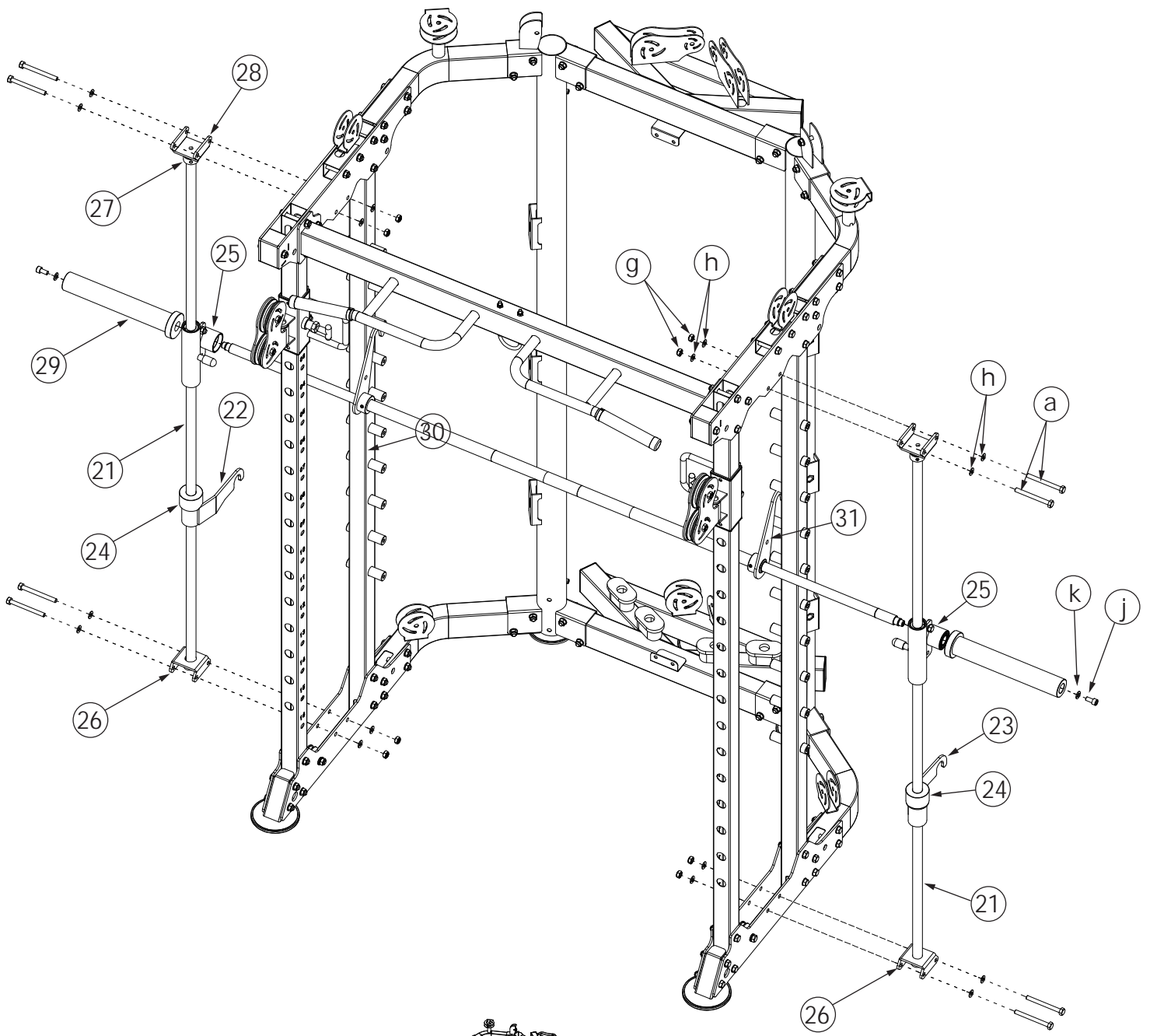

* Note: (j) & (k) are pre-installed, inside the Barbell (29).

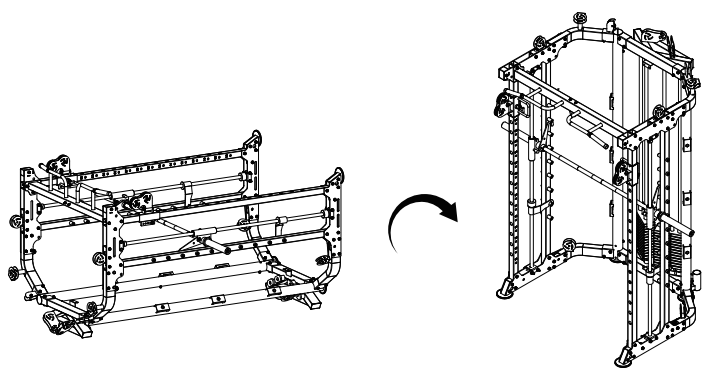

* Kindly Reminder:
You can stand the BPC05 upright from this step.

STEP 5-1 (Two People Are Required.)

NO.	DESCRIPTION	QUANTITY
32	Hoist	2
33	Top Weight Stack	2
34	Weight Stack	24
35	Weight Stack Pin	2
36	Weight Stack Plastic Sleeve	4
37	Hollow Pulley System Guiding Rod	4
38	Weight Stack Bottom Pad	4
39	Hollow Rod Top Pads	1



Scan to get
installation video

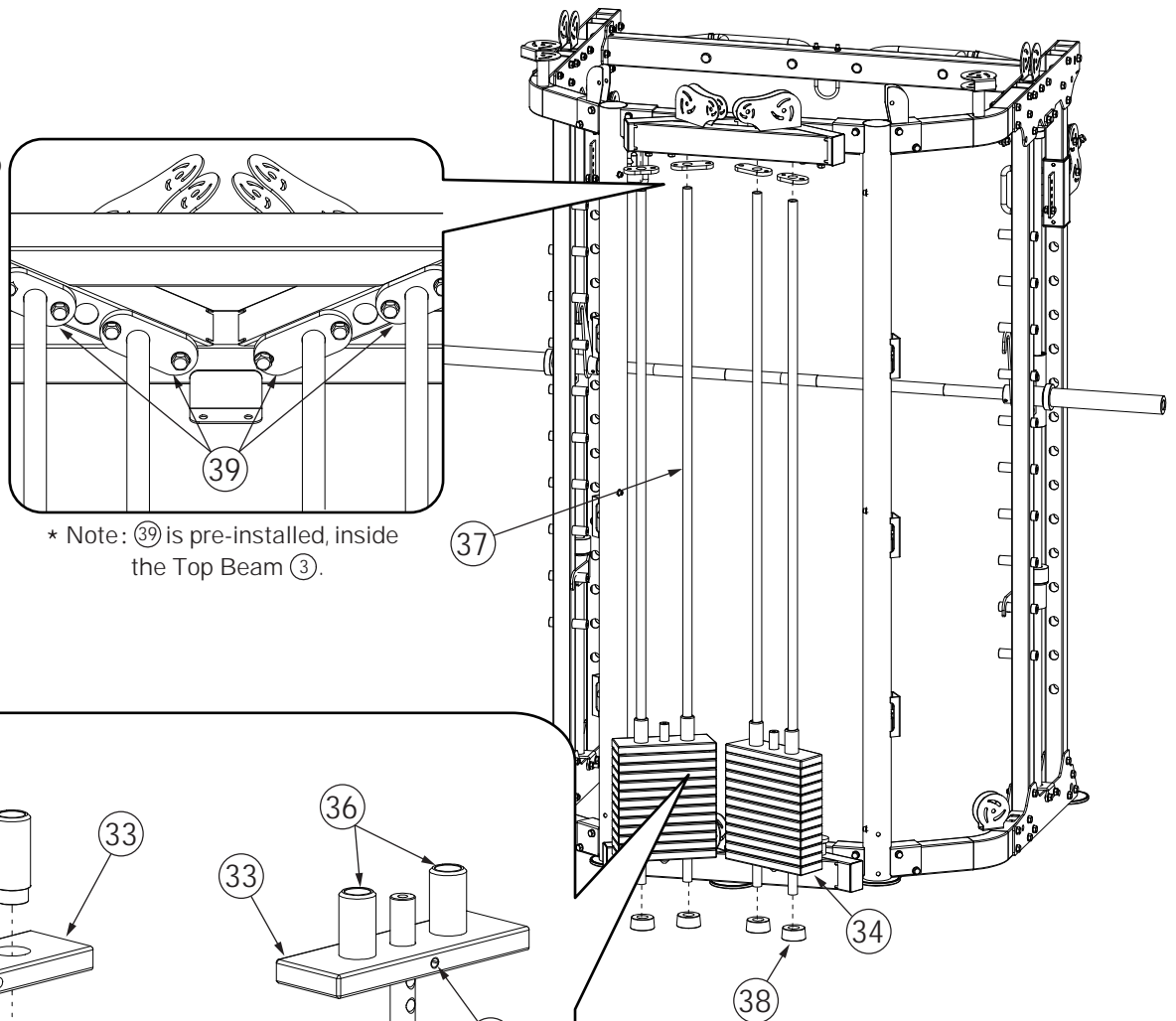

* Note: ③⑨ is pre-installed, inside the Top Beam ③.

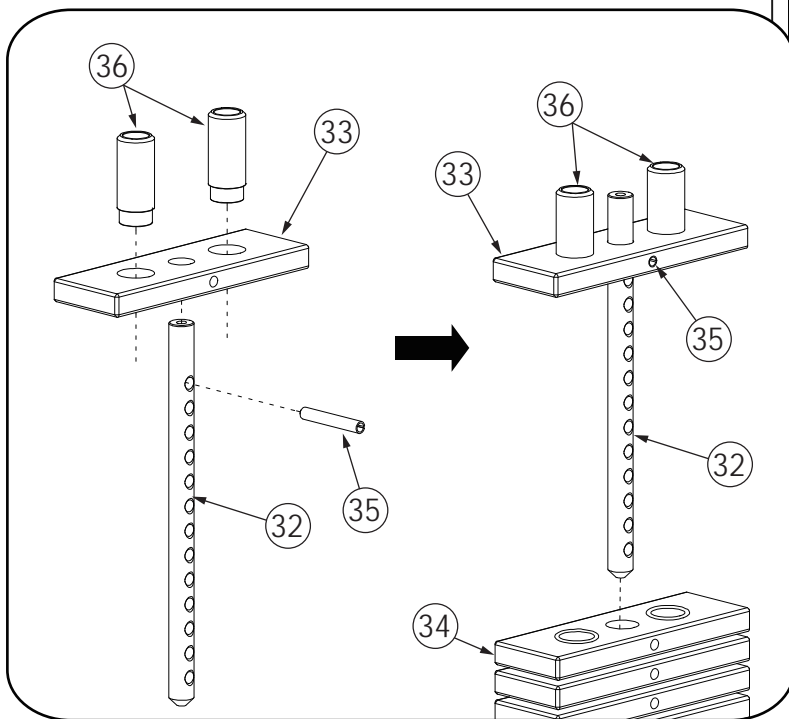

* Note: You need to strike the Weight Stack Pin ③⑤ and Plastic Sleeve ③⑥ into the Top Weight Stack ③③ using whatever tools you have (e.g. a hammer, and you need to be careful with the plastic sleeves cause they may be cracked).

STEP 5-2 (Two People Are Required.)

NO.	DESCRIPTION	QUANTITY
f	M10x25 Hex Bolt	8
h	M10 Washer	8

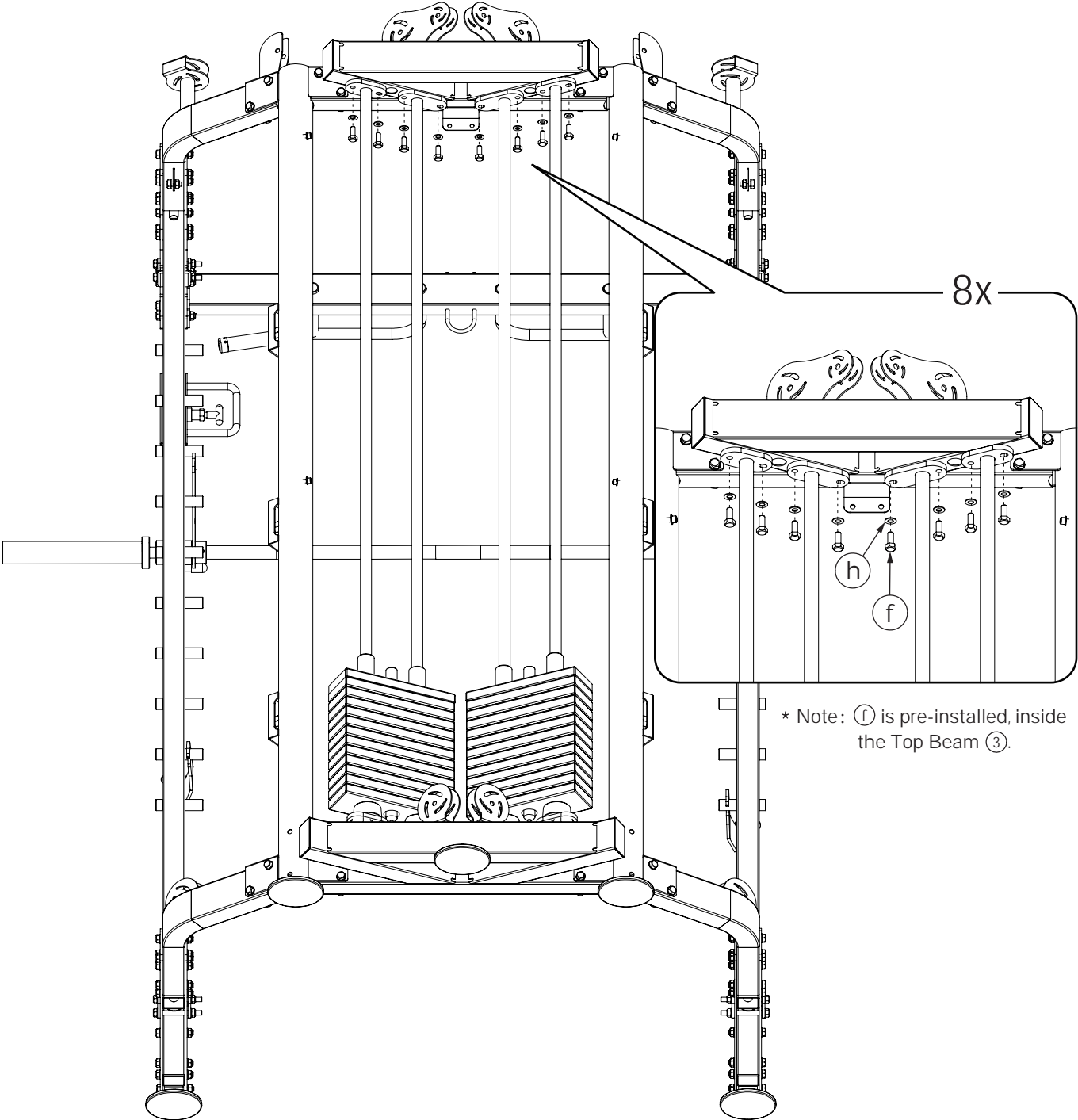

STEP 6 (Two People Are Required.)

NO.	DESCRIPTION	QUANTITY
40	Pulley B	6
41	Cable B	2
d	M10x45 Hex Bolt	6
f	M10x25 Hex Bolt	2
g	M10 Nut	6
h	M10 Washer	14



Scan to get
installation video

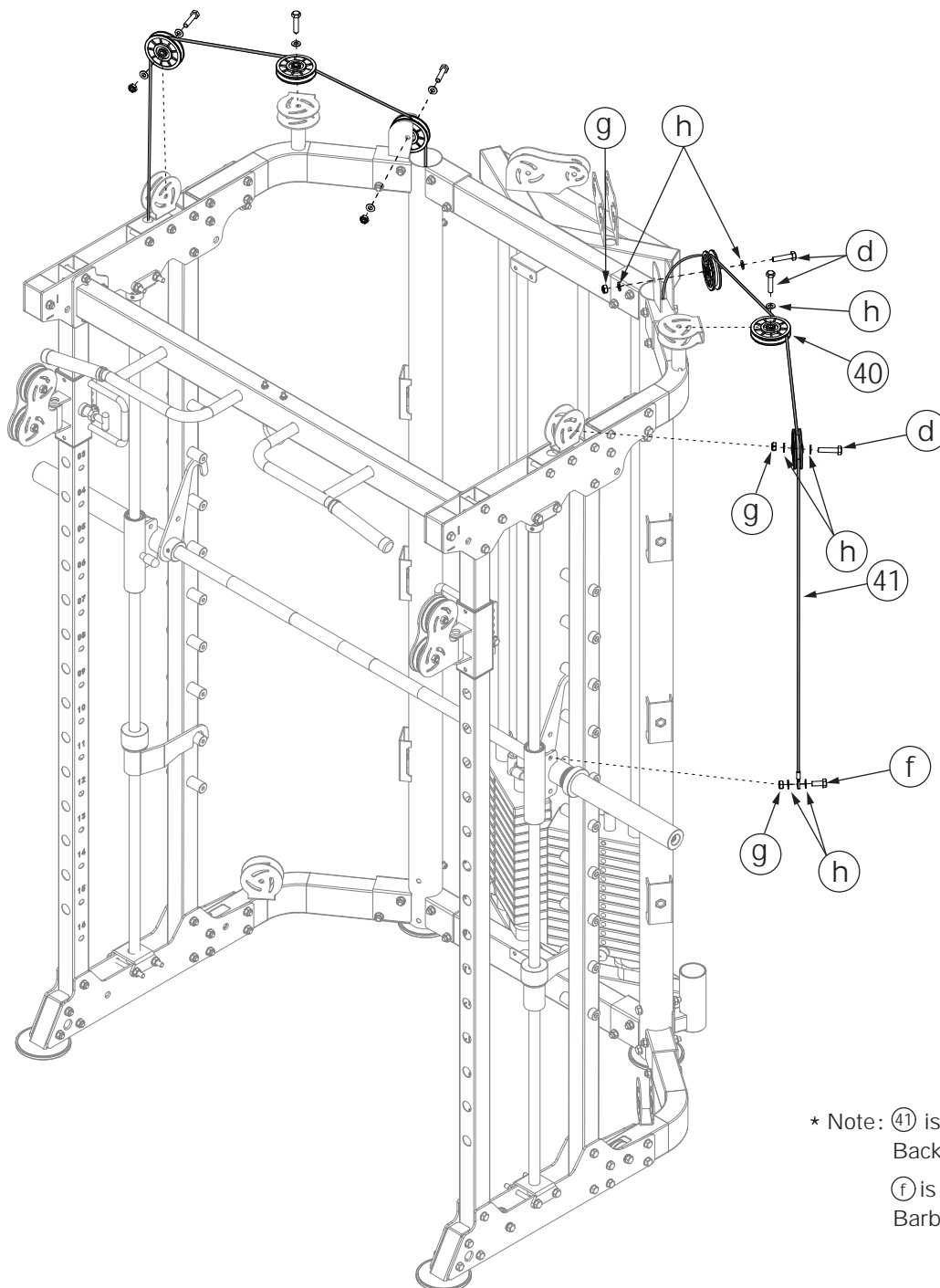

* Note: ④① is pre-installed, inside the Back Upright Frame ①&②.

④ is pre-installed, inside the Barbell Positioning Tube ②⑤.

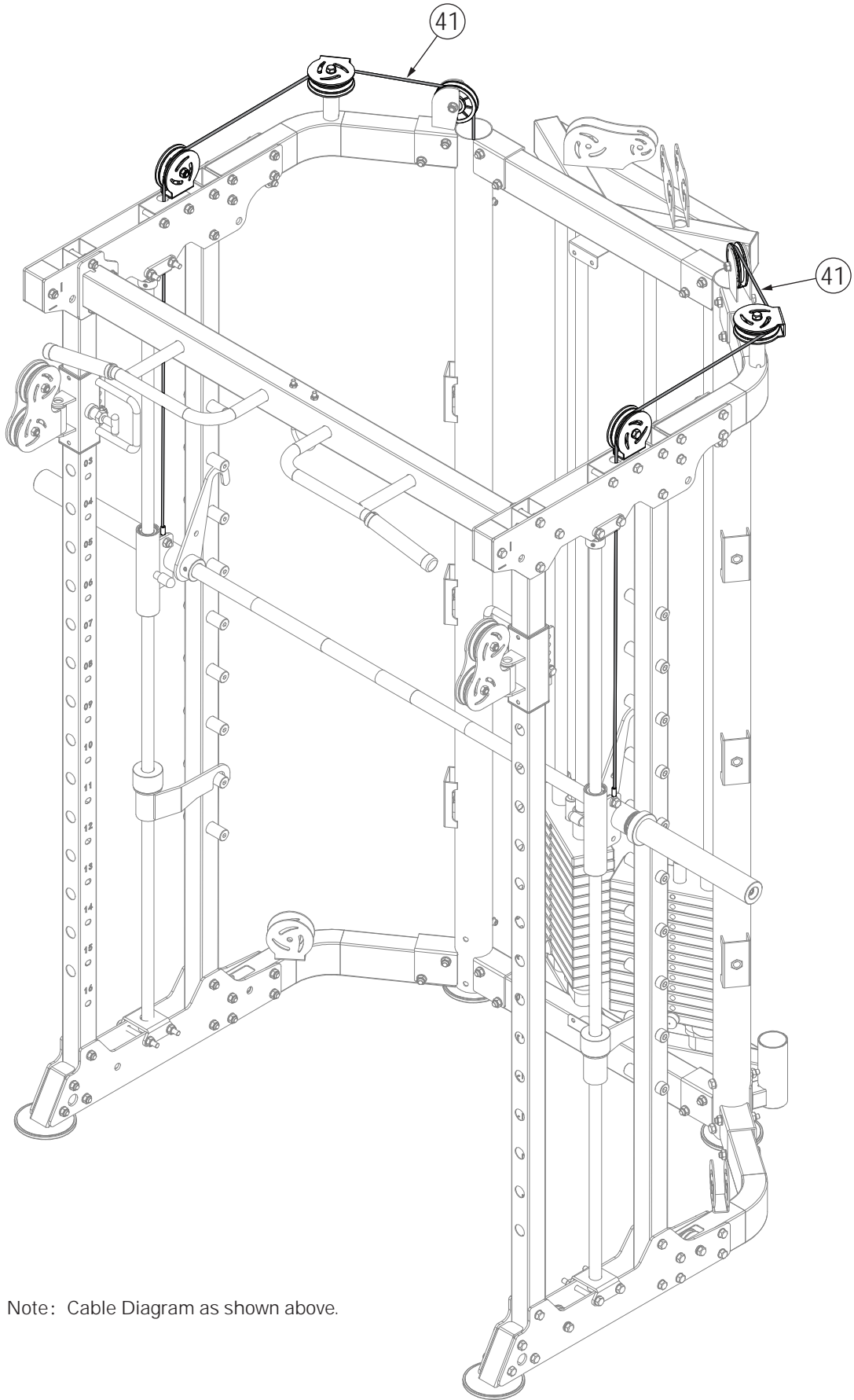

* Note: Cable Diagram as shown above.

STEP 7 (Two People Are Required.)

NO.	DESCRIPTION	QUANTITY
40	Pulley B	6
42	Pulley Peg	8
43	Double Pulley Cover	2
44	Cable C	2
b	M10x80 Hex Bolt	4
d	M10x45 Hex Bolt	2
f	M10x25 Hex Bolt	2
g	M10 Nut	8
h	M10 Washer	16

* Note: ① is pre-installed, inside the Top BentFrame (Left) ⑤ and Top Bent Frame (Right) ⑥.

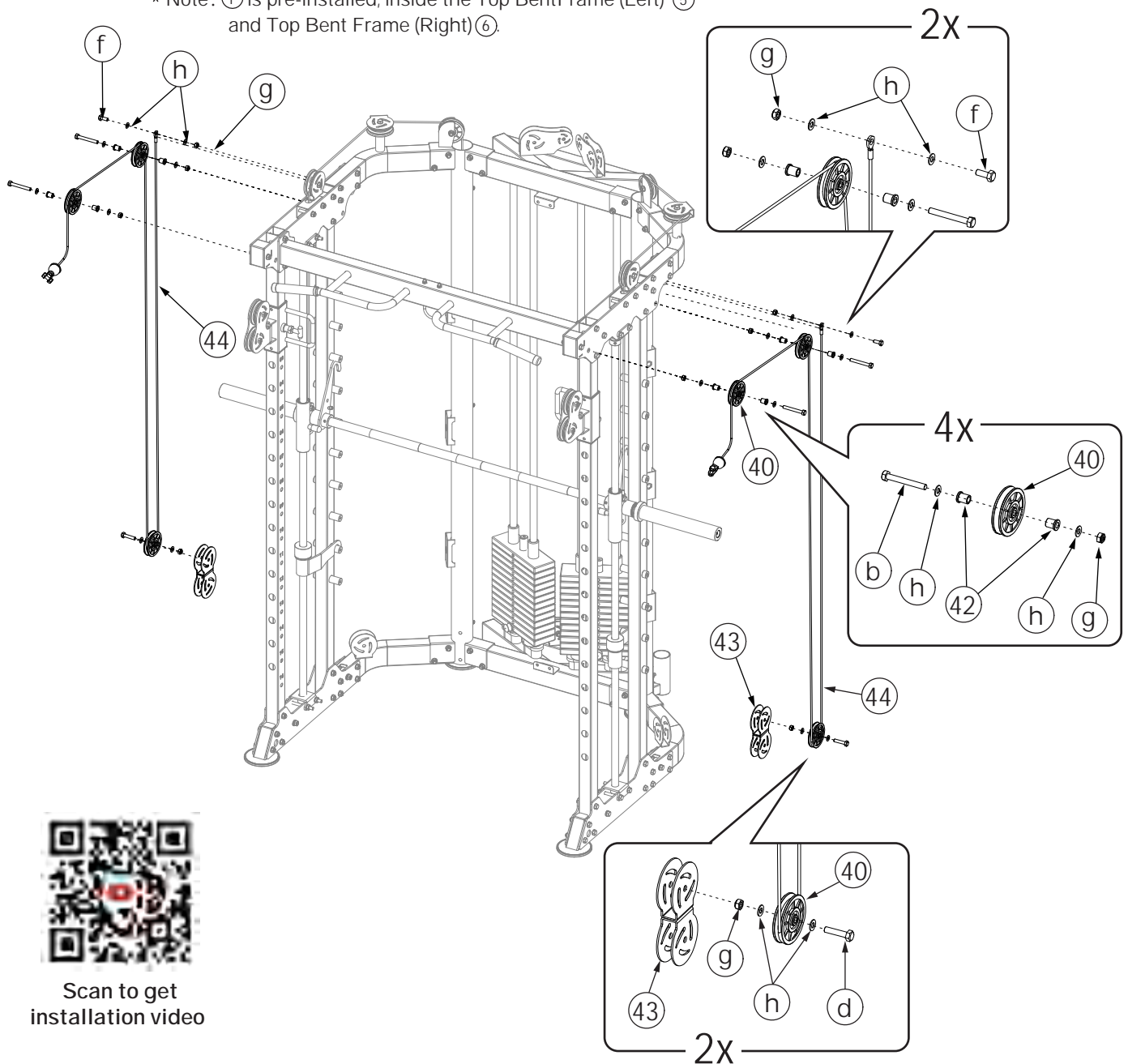

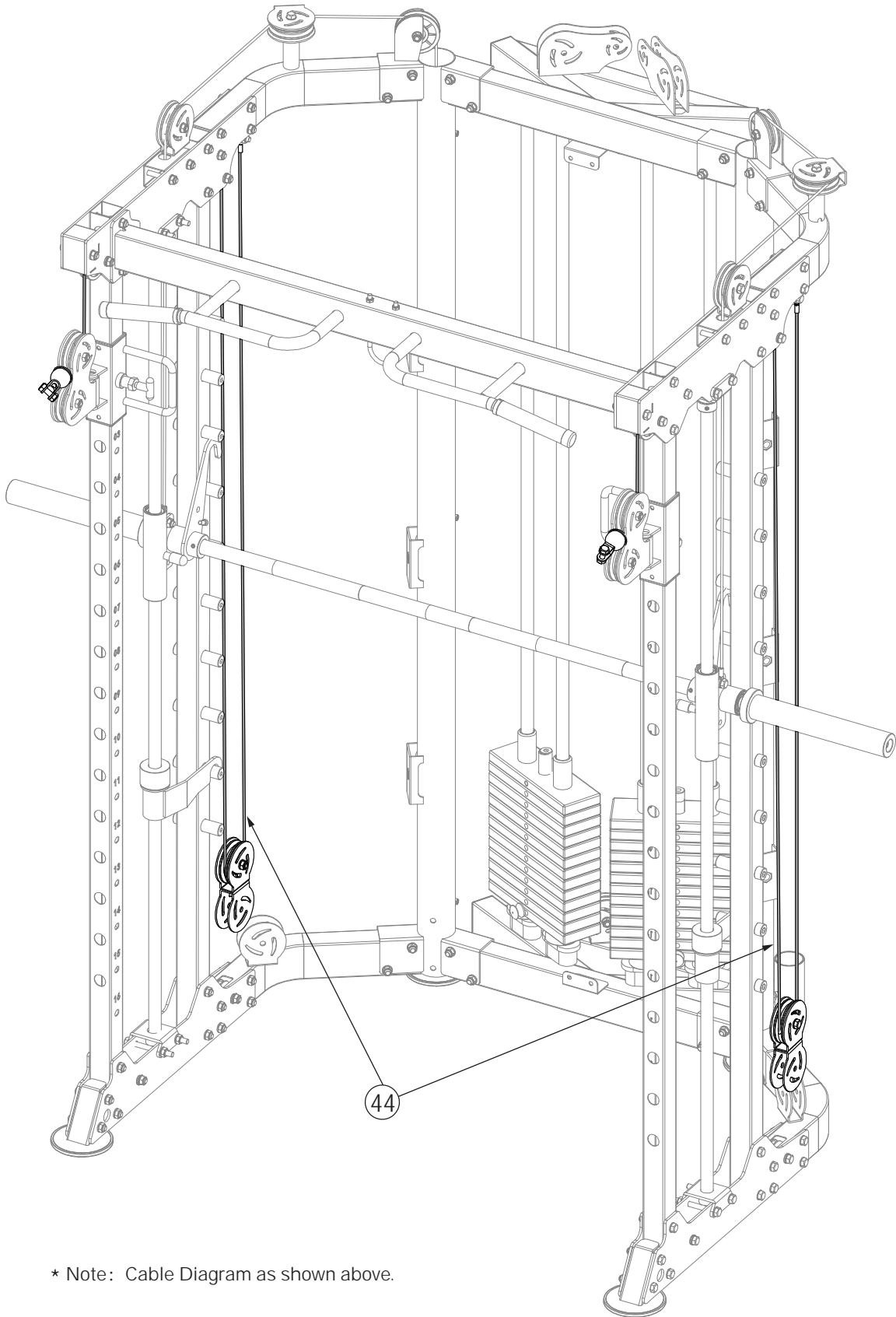

* Note: Cable Diagram as shown above.

STEP 8 (Two People Are Required.)

NO.	DESCRIPTION	QUANTITY
40	Pulley B	8
42	Pulley Peg	8
45	Pulley A	6
46	Cable A	2
b	M10x80 Hex Bolt	4
d	M10x45 Hex Bolt	10
f	M10x25 Hex Bolt	2
g	M10 Nut	16
h	M10 Washer	32

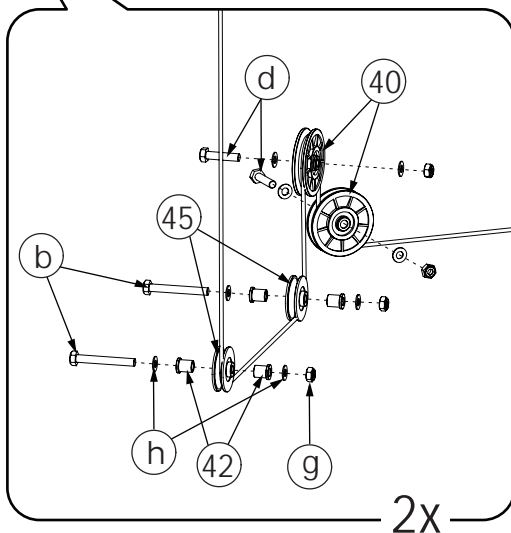
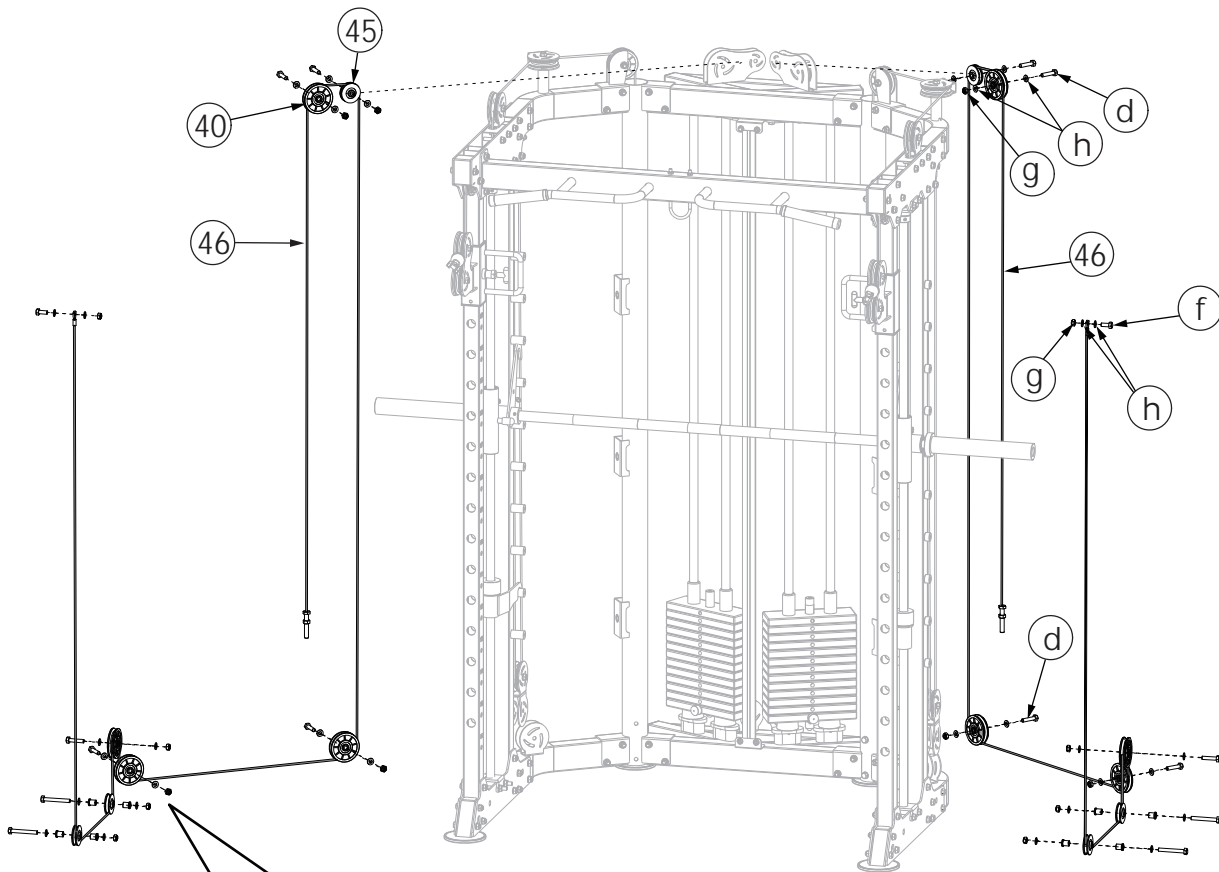

* Note: (f) is pre-installed, inside the Slider (Left) (16) and Slider (Right) (17).



Scan to get
installation video

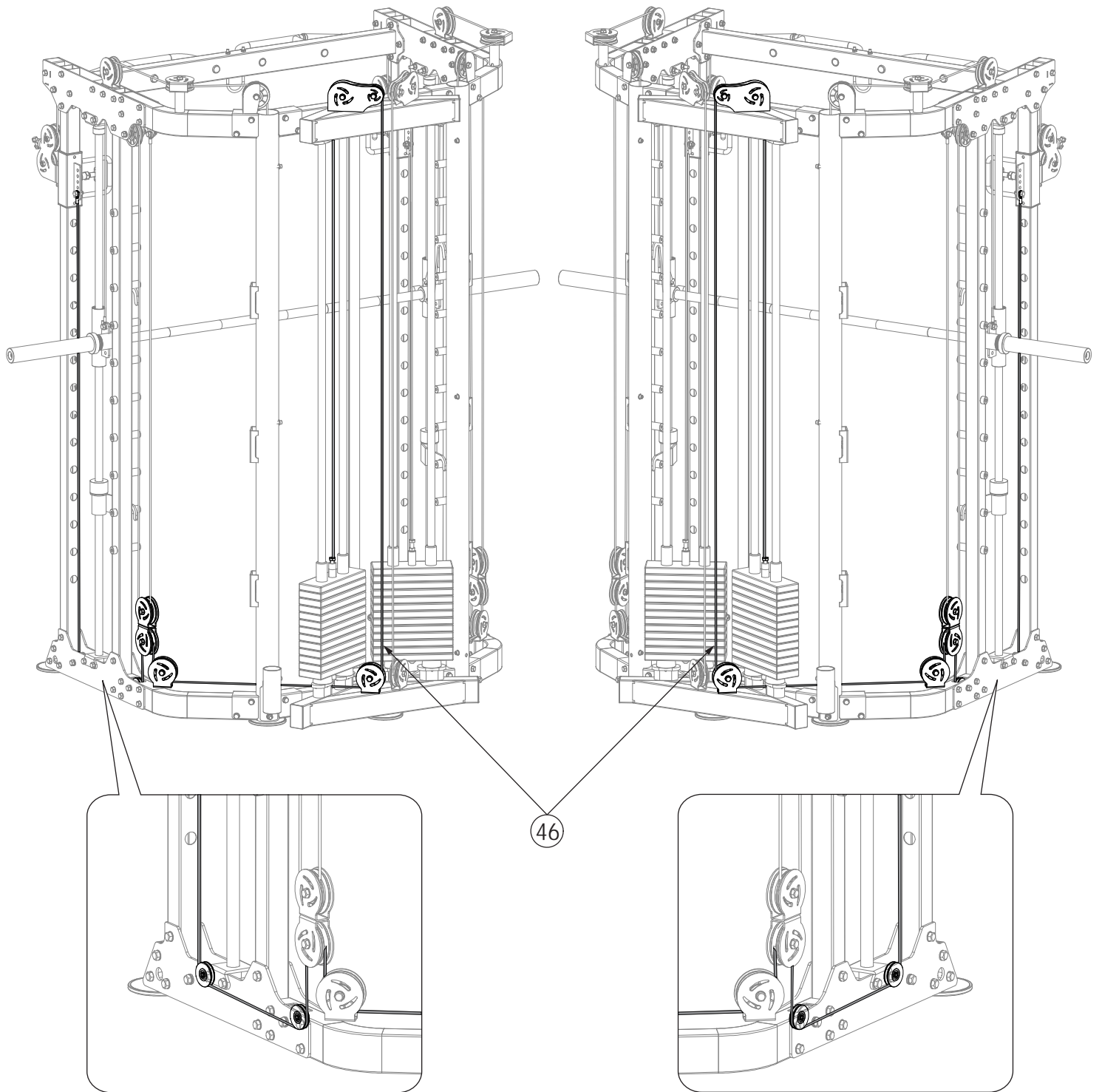

* Note: Cable Diagram as shown above.

STEP 9-1 (Two People Are Required.)

NO.	DESCRIPTION	QUANTITY
47	Cover	2
48	Poster	1
49	Hook	4
50	Cover Connector	1
64	M4 Bolt	8
65	M4 Nut	8
e	M6x15 Hexagon Screw	4
i	M6 Washer	4

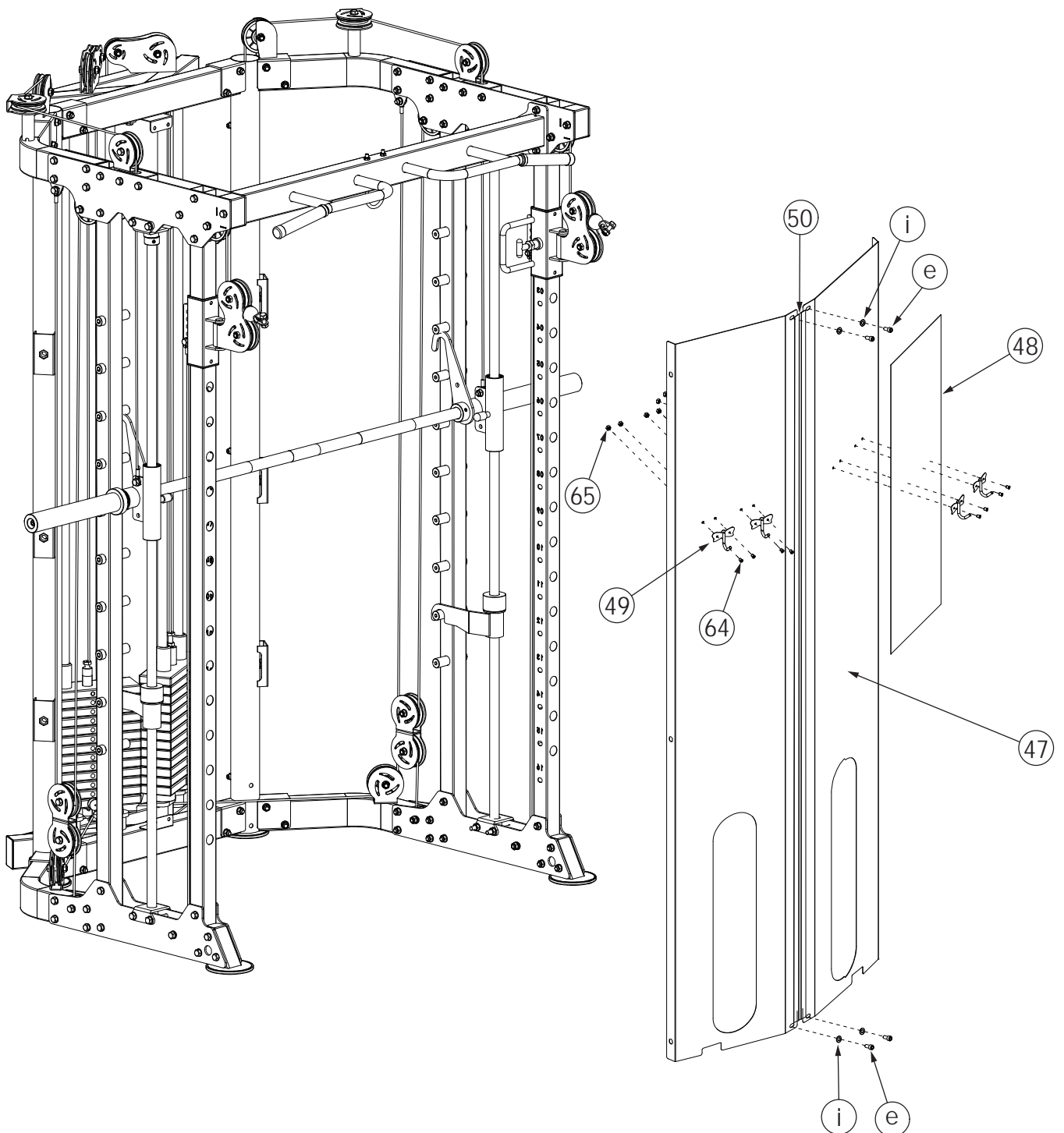

STEP 9-2 (Two People Are Required.)

NO.	DESCRIPTION	QUANTITY
e	M6x15 Hexagon Screw	6
i	M6 Washer	6

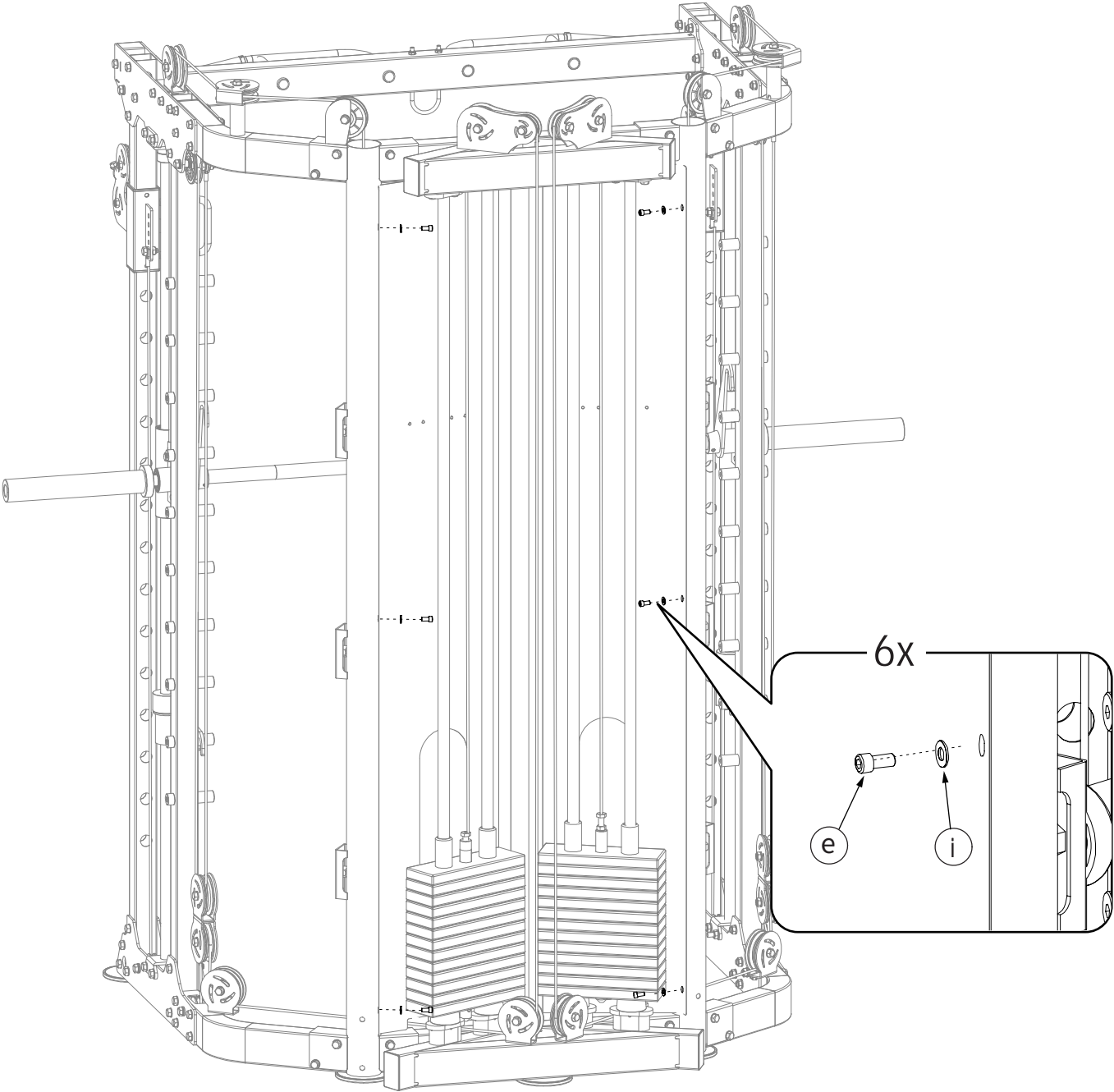

STEP 10-1

NO.	DESCRIPTION	QUANTITY
51	Plate Storage Tube	6

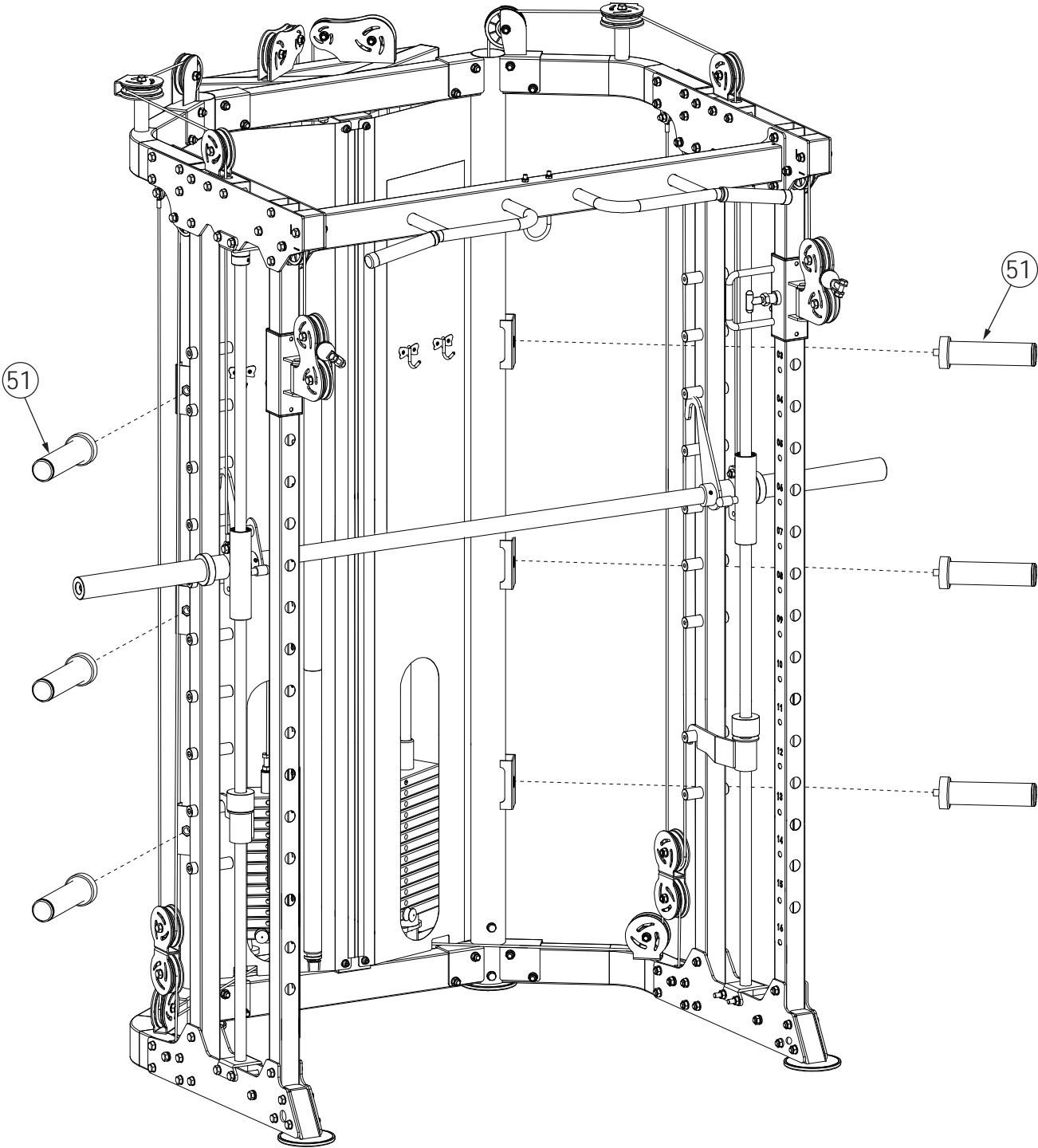

STEP 10-2

NO.	DESCRIPTION	QUANTITY
52	Barbell Storage	1
a	M10x90 Hex Bolt	2
g	M10 Nut	2
h	M10 Washer	4

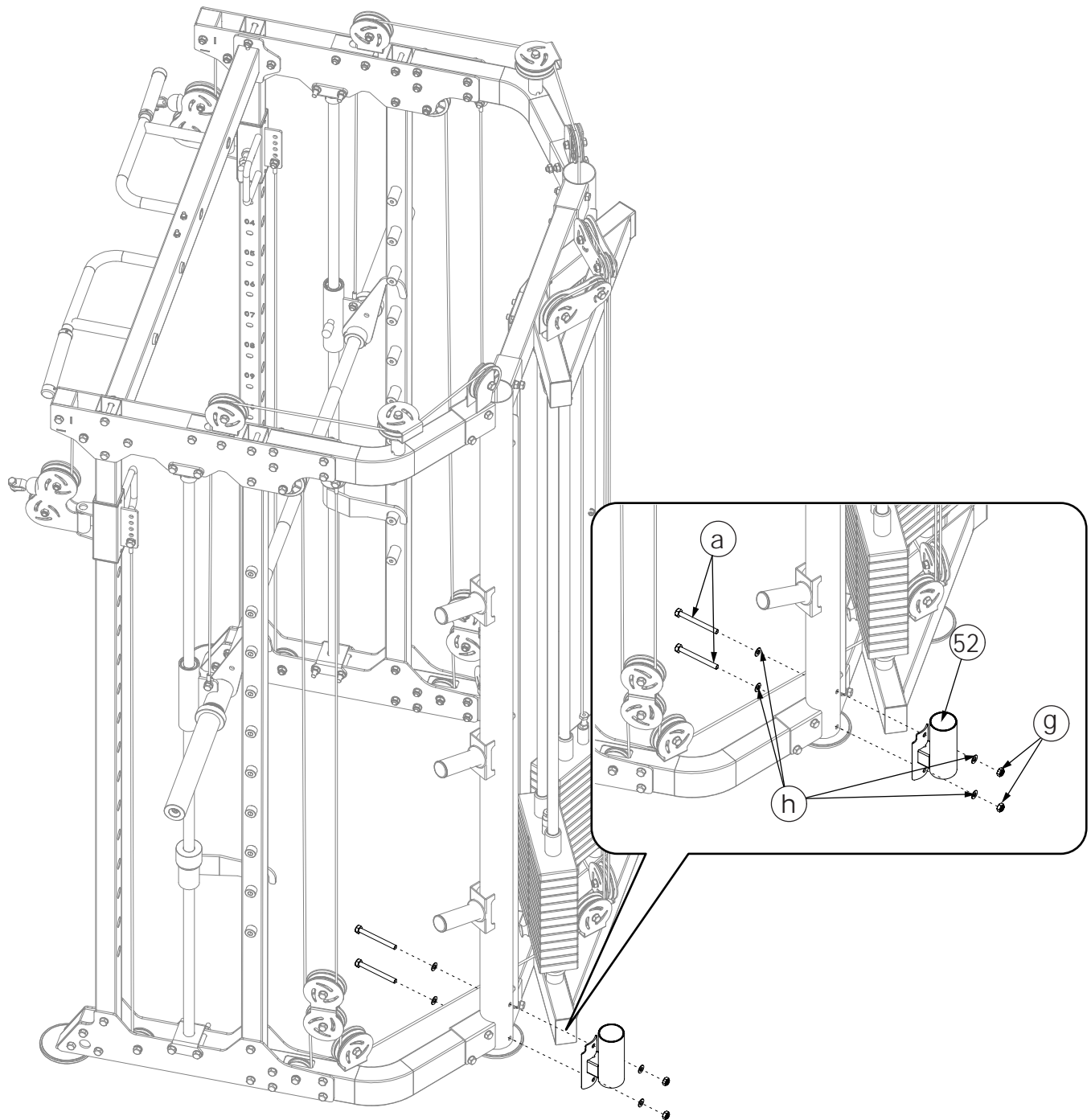

STEP 11

NO.	DESCRIPTION	QUANTITY
53	Landmine Attachment	1
54	Adjustable Pin	1
55	Leg Press Attachment	1
56	Dip Bars Set	1
57	Safety Bars Set	1
58	J-Hooks Set	1
59	Foam Roller Attachment	1
60	Lat Bar	1
61	Multi-grip Row Handle Set	1
66	Pulley Handle	2

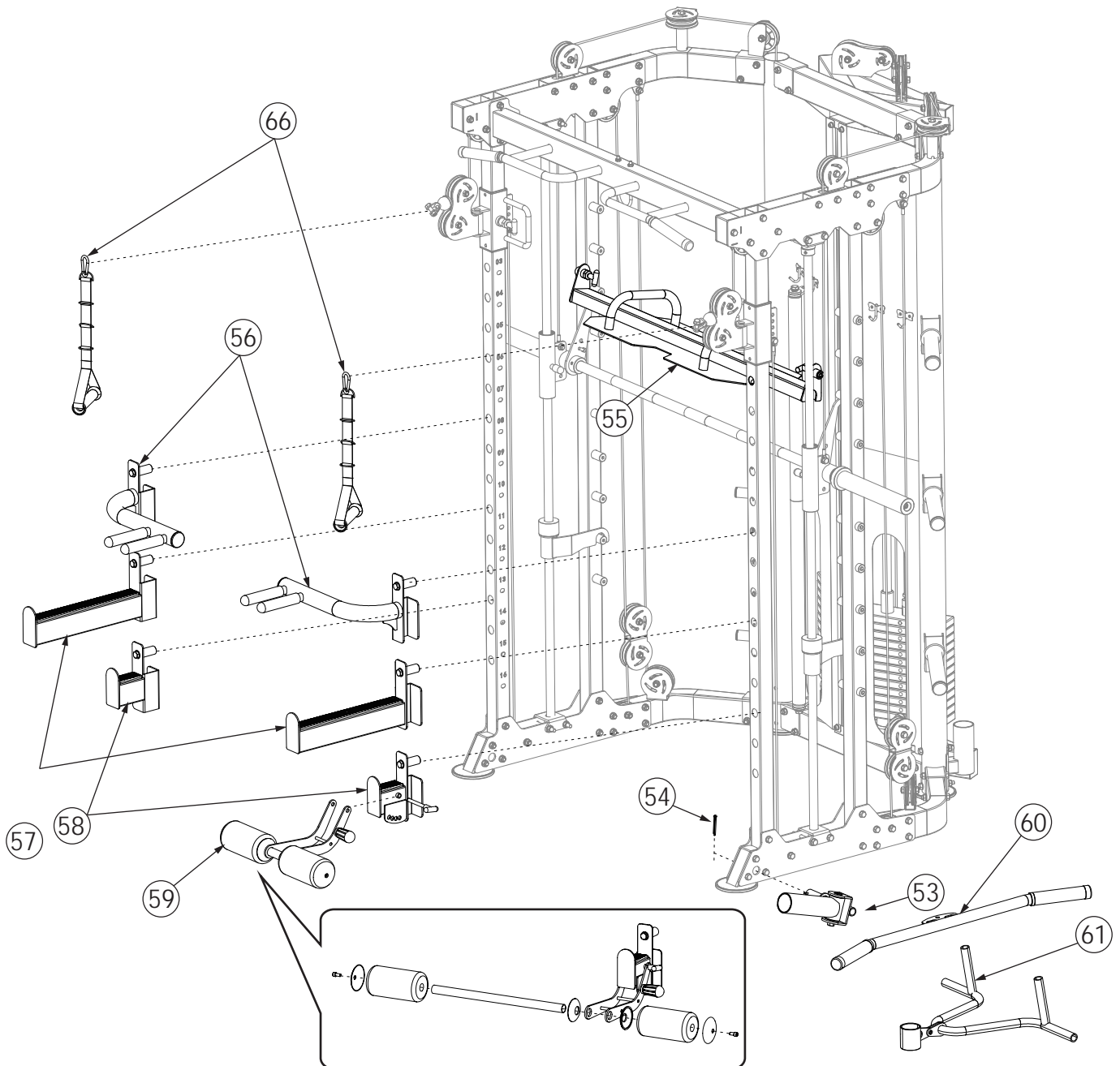

END

Congratulations!

You have assembled the Multifunctional Power Cage!
Now, you can officially start strength training with RITFIT.

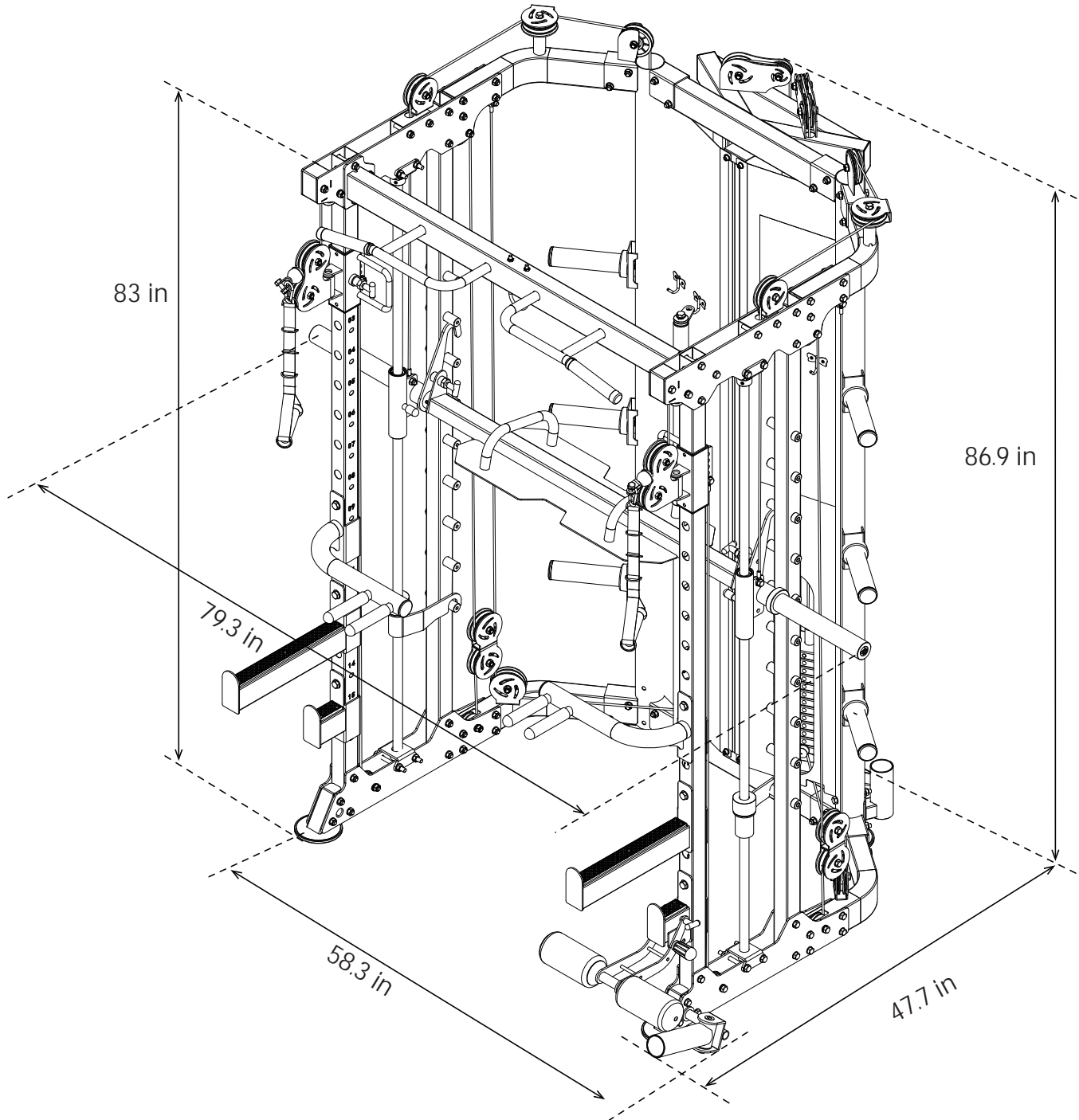

Don't mind if you have extra fasteners after installation, which can be used as future replacement parts.

Power Cage Warranty

A. What's Covered Under RitFit LLC's Basic Warranty?

Basic Warranty.

B. Who Is Covered?

You are covered by the Basic Warranty if you are a purchaser for use of the RitFit Power Cage.

C. What's Covered?

The Basic Warranty covers the cost of all parts and labor needed to repair any item on your power cage when it left the manufacturing plant that is defective in material, workmanship or factory preparation. These warranty repairs or adjustments will be made by RitFit at no charge, using new or remanufactured parts.

D. When It Begins?

The Basic Warranty begins on the day of order.

E. When It Ends?

The Basic Warranty lasts for 36 months from the date it begins, but the following items are covered only for 12 months: bolts; nuts; washers; tube bushings; foot covers; pulley sleeve; pulleys; chains; gourd buckles; cables; top beam; J-hooks; plate carriage; pulley brace; plate storage pegs.

F. What's Not Covered?

Please note that while the standard Basic Warranty applies to defects in material and/or workmanship, it does not cover the power cage's matte finish appearance. Maintaining the matte finish appearance is solely the responsibility of the owner. Basic Warranty doesn't cover damage caused by environmental factors such as airborne fallout, insect damage, chemicals, salt, and ocean spray. Nor do your warranty cover damage caused by hailstorms, windstorms, tornadoes, sandstorms, lightning, floods, and earthquakes. Your warranty does not cover conditions resulting from anything impacting the multifunctional power cage.

G. How To Contact Us?

To ensure you receive the best technical support, please visit our website: www.ritfitsports.com and register your warranty. Customers with registered warranties are given a profile that allows for easier support and for us to contact you with important product notifications. If any parts are missing, worn, damaged or broken before the assembly, or you ever need to replace the parts, please contact us at support@ritfitsports.com.

RITFIT

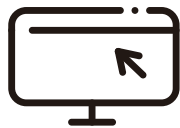

www.ritfitsports.com

SUBSCRIBE WEBSITE AND GET

- Free Exercise Ebook
- Lastest Updates



GOT A PROBLEM? GET IN TOUCH
support@ritfitsports.com

GET SOCIAL WITH US

 [@ritfit.sports](https://www.instagram.com/ritfit.sports)