

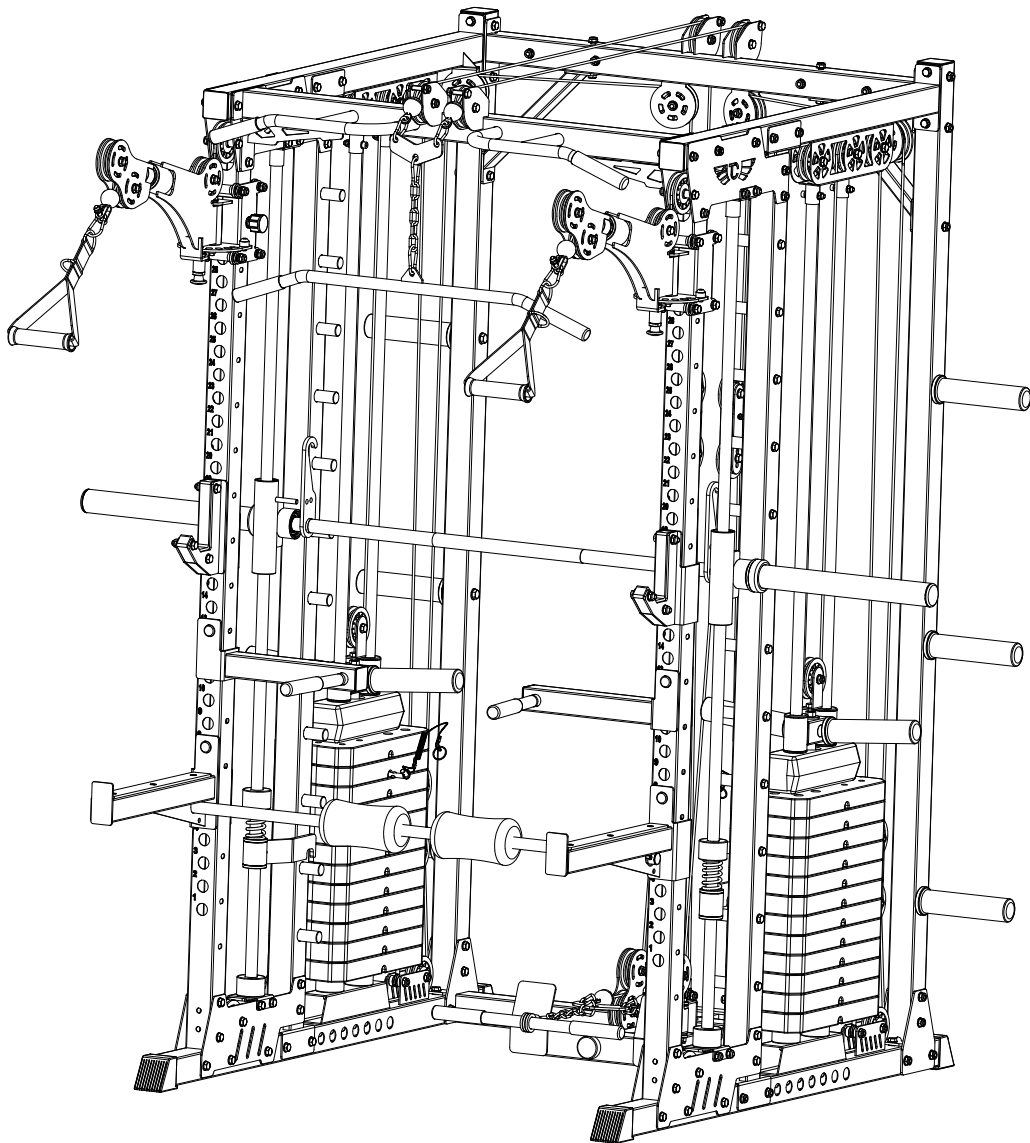

TRAINING CAMP

OWNER'S MANUAL

TC-K2S



Product may vary slightly from the item pictured due to model upgrades.



**Read all instructions carefully before using this product.
Retain this owner's manual for future reference.**



TABLE OF CONTENTS

I. Important Safety Instructions	01
II. Care Instructions	02
III. Parts List	04
IV. Assembly Instructions	12
V. Exercise Guide	30
VI. Maintenance	32

I. IMPORTANT SAFETY INSTRUCTIONS



WARNING: Read all instructions before using this machine.

To ensure your safety, read the following precautions before using this product.

1. Please read, study and understand the instructions and all warning labels before use.
(It is recommended to be familiar with the normal operation and use methods of the device before using this product. Information is available on this manual and at local retailers).
2. Please keep this manual and ensure that all the warning labels are clear and complete.
3. This product is recommended to install by more than two people.
4. Please consult your doctor's advice before starting the exercise.
5. Please ensure safety when the children are present.
6. Be careful when using it with children present.
7. Please check any signs of wear of the wire rope regularly. If there is wear, it may cause some danger to you.
8. Please keep your hands, limbs and clothes stretch to use the device.
9. Please note any signs of machinery that may occur, including part wear, loose hardware, and welding cracks. Stop using the device with the above signs immediately and contact the after-sales service department of our company.
10. You can complete the assembly with a wrench, or an inner hexagon wrench.
11. The user weight of this product shall not exceed 100kg.
12. The product is subject to change without notice and the final interpretation belongs to the Division.

WARNING: BEFORE BEGINNING ANY EXERCISE PROGRAM, CONSULT YOUR PHYSICIAN. THIS IS ESPECIALLY IMPORTANT FOR INDIVIDUALS OVER THE AGE OF 35 OR PERSONS WITH PRE-EXISTING HEALTH PROBLEMS. READ ALL INSTRUCTIONS BEFORE USING ANY FITNESS EQUIPMENT. WE ASSUME NO RESPONSIBILITY FOR PERSONAL INJURY OR PROPERTY DAMAGE SUSTAINED BY OR THROUGH THE USE OF THIS PRODUCT.

SAVE THESE INSTRUCTIONS.

II. CARE INSTRUCTIONS

- Lubricate moving joints with silicon spray after periods of usage.
- Be careful not to damage plastic or metal parts of the machine with heavy or sharp objects.
- The machine can be kept clean by wiping it down using dry cloth.
- Check and adjust the tension of wire rope on a regular basis.
- Regularly check all moving parts and make sure there are signs of wear and damage, if any the use of the device must be stopped immediately and contact our after-sales department.
- During inspection, it is necessary to make sure that all bolts and nuts are completely fixed. If any bolt or nut connection is loosened, please re-tighten.
- Check weld for cracks.

Assembled Dimension: 2066mm x 1802mm x 2201mm

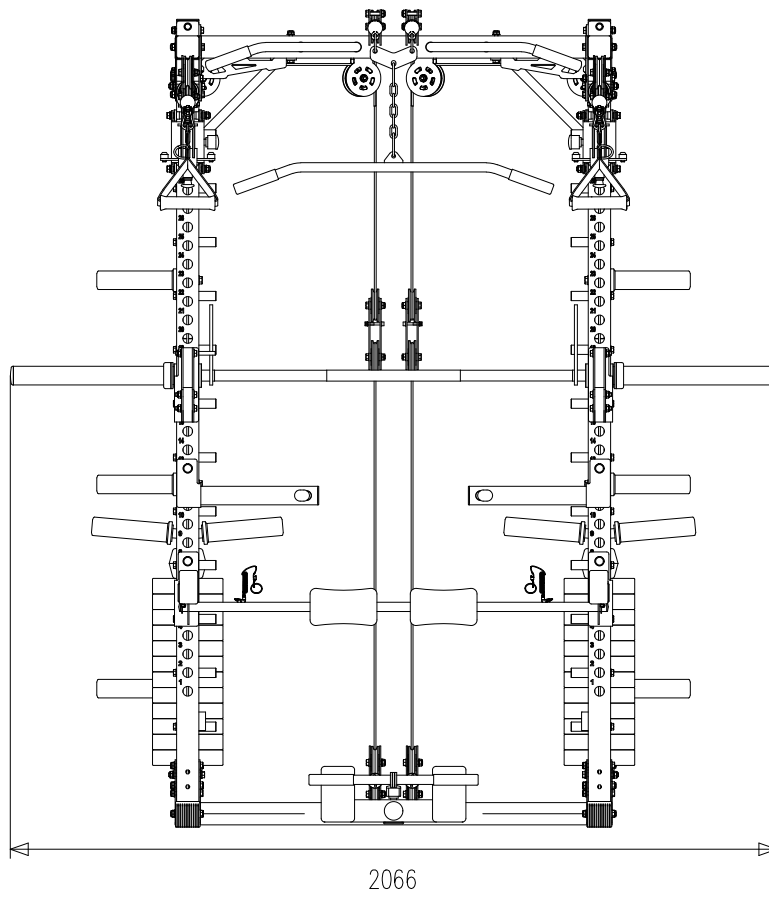
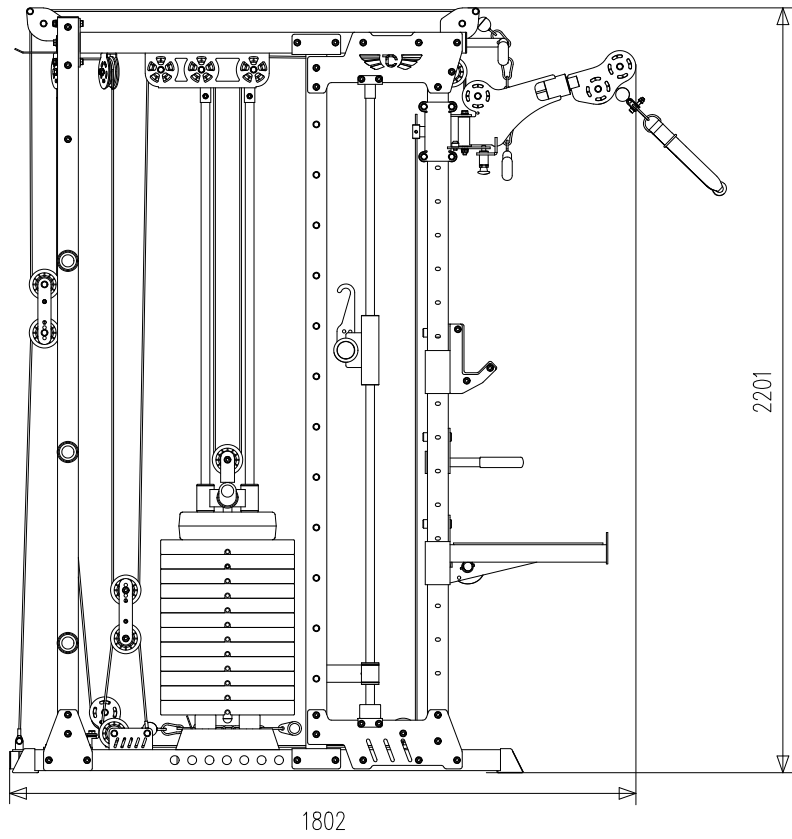

III. PARTS LIST

KEY NO.	PART DESCRIPTION	SPEC	QTY
1	Base Frame L		1
2	Base Frame R		1
3	Connecting Frame Rear		1
4	Rear Post		2
5	Top Frame L		1
6	Top Frame R		1
7	Intermediate Stand 1		2
8	Pulley_support		2
9	Horizontal bar		1
10	Weight Rod	Ø30x2005xM12	1
11	Foot Pedal Set		1
12	Connecting Part01		2
13	Connecting Part02		2
14	Guide Shaft	60x60x2x1935	2
15	Guide Rod Rear	Ø25x1848	4
16	Guide rod	Ø25x1810	2
17	Connecting Part03		2
18	Connecting Part04		2
19	Connecting Part05		4
20	Shelf board		2
21	Mobile rack L		1
22	Mobile rack R		1
23	Safety hook Bracket L		1
24	Safety hook Bracket R		1
25	Connecting Part06		2
26	Connecting Part07		2
27	Long Spacer		2
28	Short Spacer_A		6
29	Sliding frame L		1
30	Sliding frame R		1
31	Connecting Part08		8
32	Rubber Stopper		8
33	Spring	Ø5-Ø26-65	2
34	Pulley	Ø90	40
35	Left Chin-up Bar		1
36	Right Chin-up Bar		1
37	Top Weight Plate Connecting Part01		2
38	Pulley Case		2
39	Short Spacer_B		6

PART LIST

KEY NO.	PART DESCRIPTION	SPEC	QTY
40	hanging post		24
41	Top Weight Plate		2
42	Weight Plate		24
43	Selector Rod	Ø25X640(12+1)	2
44	Long Safety Rack L		1
45	Long Safety Rack R		1
46	Rod		1
47	Dip Bar L		1
48	Dip Bar R		1
49	Sandwich-type hook L		1
50	Sandwich-type hook R		1
51	Foam		2
52	Handle A		1
53	Handle B		1
54	Nylon Strap ISO-Handle		2
55	5-Joint Chain		2
56	Spring Clip		6
57	Hook	Ø5	10
58	Weight Selector Pin		2
59	Ring pin		8
60	Spacer		8
61	Bushing		12
62	Bushing		4
63	Nylon pad		4
64	Pull cable	9400mm	2
65	Pull cable	3600mm	2
66	Pull cable	3480mm	2
67	Connecting Part07		2
68	Weight Plate Sticker		2
69	#		
70	#		
71	#		
72	#		
73	#		
74	#		
75	#		
76	#		
77	#		
78	#		

PART LIST

KEY NO.	PART DESCRIPTION	SPEC	QTY
80	Screw	M6x45	4
81	HEX Bolt	M10X45	34
82	HEX Bolt	M10X50	2
83	HEX Bolt	M10X70	6
84	HEX Bolt	M10X80	56
85	HEX Bolt	M12X90	2
86	Lock Nut	M12	2
87	Lock Nut	M10	124
88	Lock Nut	M6	6
89	Washer	12	12
90	Washer	10	280
91	Washer	6	12
92	HEX Bolt	M10X25	30
93	HEX Bolt	M12X25	10
94	Screw	M12X20	2
95	HEX Bolt	M10X90	8
96	HEX Bolt	M10X20	2
97	HEX Bolt	M10X85	6
98	Screw	M8X45	4
99	Nut	M8	4
100	Washer	8	8
101	Nut	M12	2
102	Washer	Ø13XØ37	2
103	Spring Washer	12	4
	Allen wrench	#4	1
	Allen wrench	#5	1
	Allen wrench	#6	1
	Allen wrench	#10	1
	Open-end Wrench	8/10	1
	Open-end Wrench	13/17	1
	Open-end Wrench	17/19	1

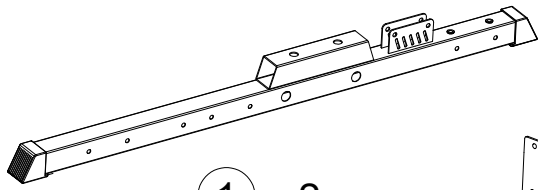

① x 2

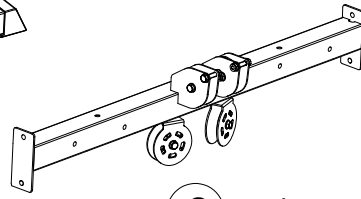

② x 1

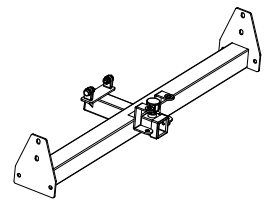

③ x 1

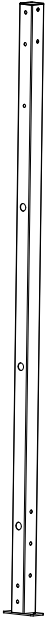

④ x 2

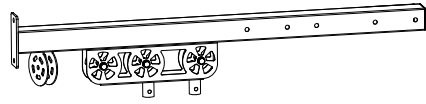

⑤ x 1

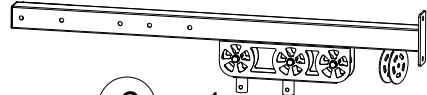

⑥ x 1



⑦ x 2

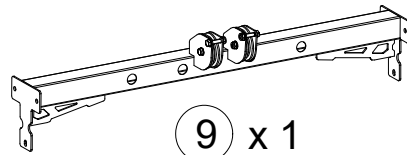

⑨ x 1

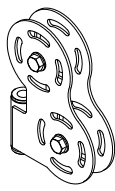

⑧ x 2

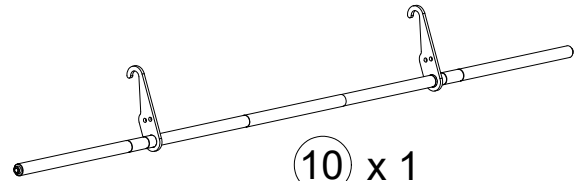

⑩ x 1

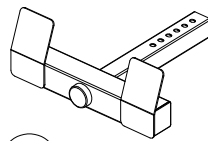

⑪ x 1

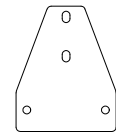

⑫ x 2

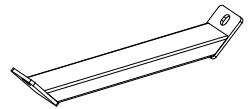

⑬ x 2



⑭ x 2



⑮ x 4



⑯ x 2

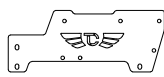

⑰ x 2



⑱ x 2

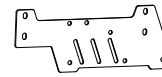

⑲ x 4

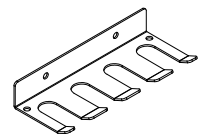

⑳ x 2

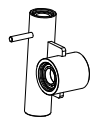

㉑ x 1

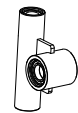

㉒ x 1

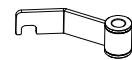

㉓ x 1

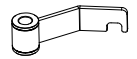

㉔ x 1



㉕ x 2



㉖ x 2



㉗ x 2

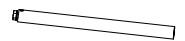

㉘ x 6

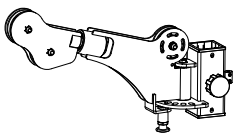

㉙ x 1

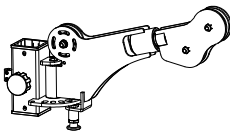

㉚ x 1

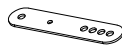

㉛ x 8



㉜ x 8



㉝ x 2

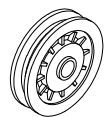

㉞ x 40

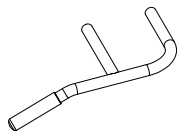

35 x 1

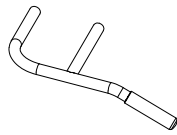

36 x 1

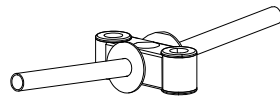

37 x 2



38 x 2

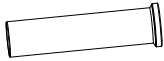

39 x 10

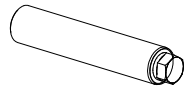

40 x 24

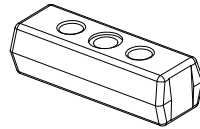

41 x 2

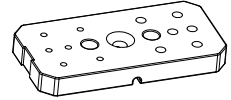

42 x 24

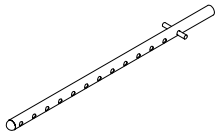

43 x 2

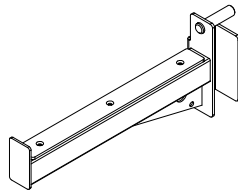

44 x 1

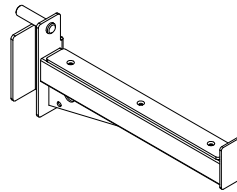

45 x 1

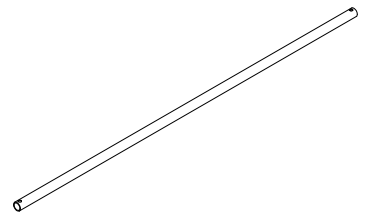

46 x 1

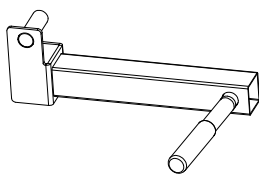

47 x 1

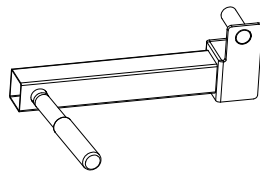

48 x 1

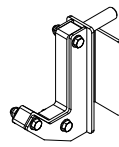

49 x 1

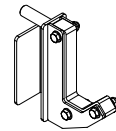

50 x 1

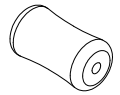

51 x 2

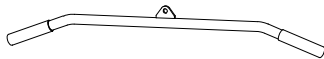

52 x 1

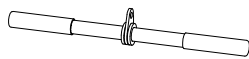

53 x 1

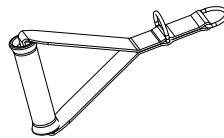

54 x 2

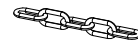

55 x 2



56 x 6



57 x 10



58 x 2



59 x 2



60 x 8



61 x 12



62 x 4



63 x 4

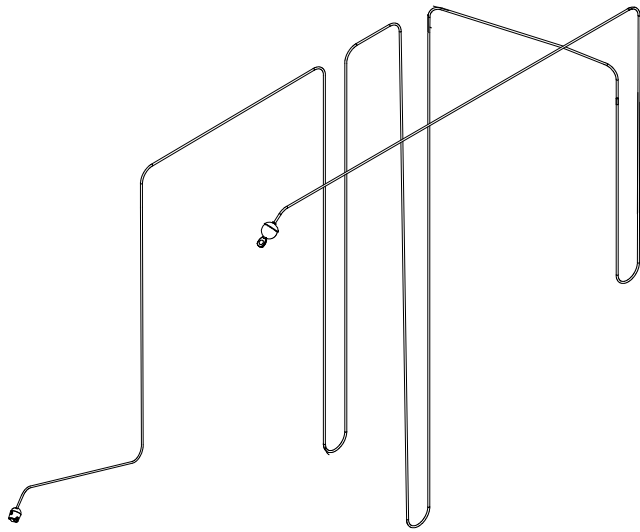

64 x 2

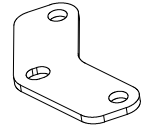

67 x 2

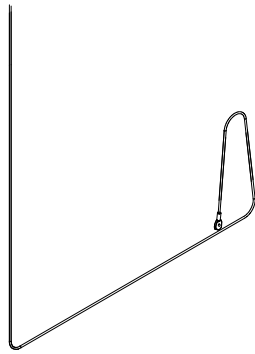

65 x 2



8/10 x 1

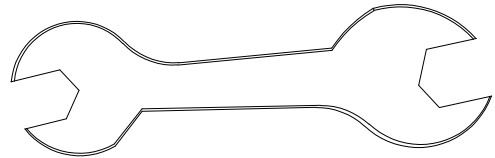

13/17 x 1

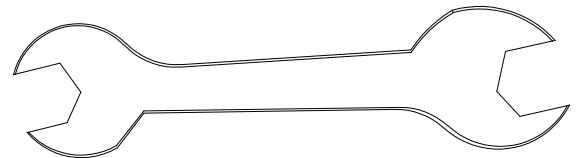

17/19 x 1

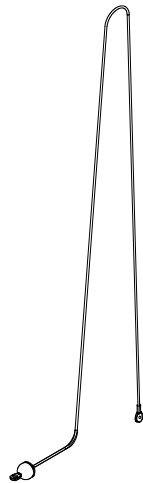

66 x 2

Step 1: Open the bag of mixed bolts, measure them against the ruler here to determine the correct bolt sizes

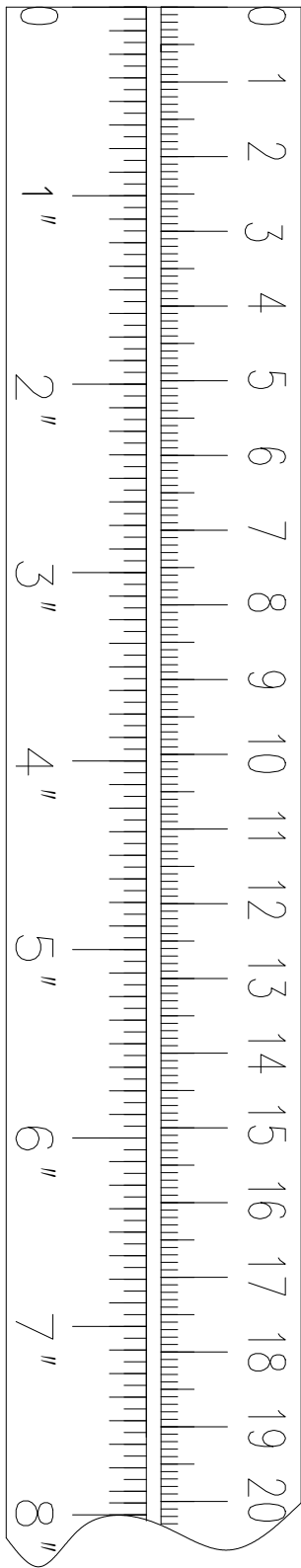







mm	(80) x4			(101) x2
1	(81) x34			
2	(82) x2			
3	(83) x6			
4	(84) x56			(102) x2
5	(85) x2			
6	(95) x8			
7	(97) x6			
8	(92) x30			
9	(93) x10		(86) x2	(87) x124
10	(94) x2			(88) x6
11	(96) x2			
12	(98) x4		(89) x12	(90) x280
13				(91) x12
14				
15				
16				
17				
18				
19				
20				

	# 4 x1		
	# 5 x1		
	# 6 x1	(99) x4	(100) x8
	# 10 x1		

IV. ASSEMBLY INSTRUCTIONS

*Leave your bolts only finger-tight as you assemble. Save all the tightening to the very end. This will allow for wiggle room to fit parts into place.

- | | | | | | | | | |
|----|---|-------------|----|---|---------|----|---|-----------|
| ⑨2 |  | x 2 M10 x25 | ⑧7 |  | x 6 M10 | ⑨0 |  | x 12 Ø 10 |
| ⑧1 |  | x 4 M10x45 | ⑧6 |  | x 2 M12 | ⑧9 |  | x 4 Ø 12 |
| ⑧5 |  | x 2 M12x90 | | | | | | |

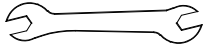

Note:

Spacers will already exist where the pulleys go. They are set as "placeholders". Remove them to insert the pulleys.

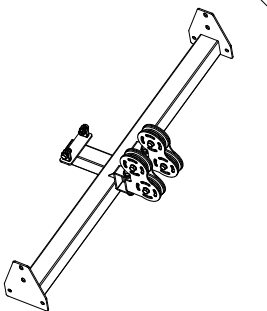
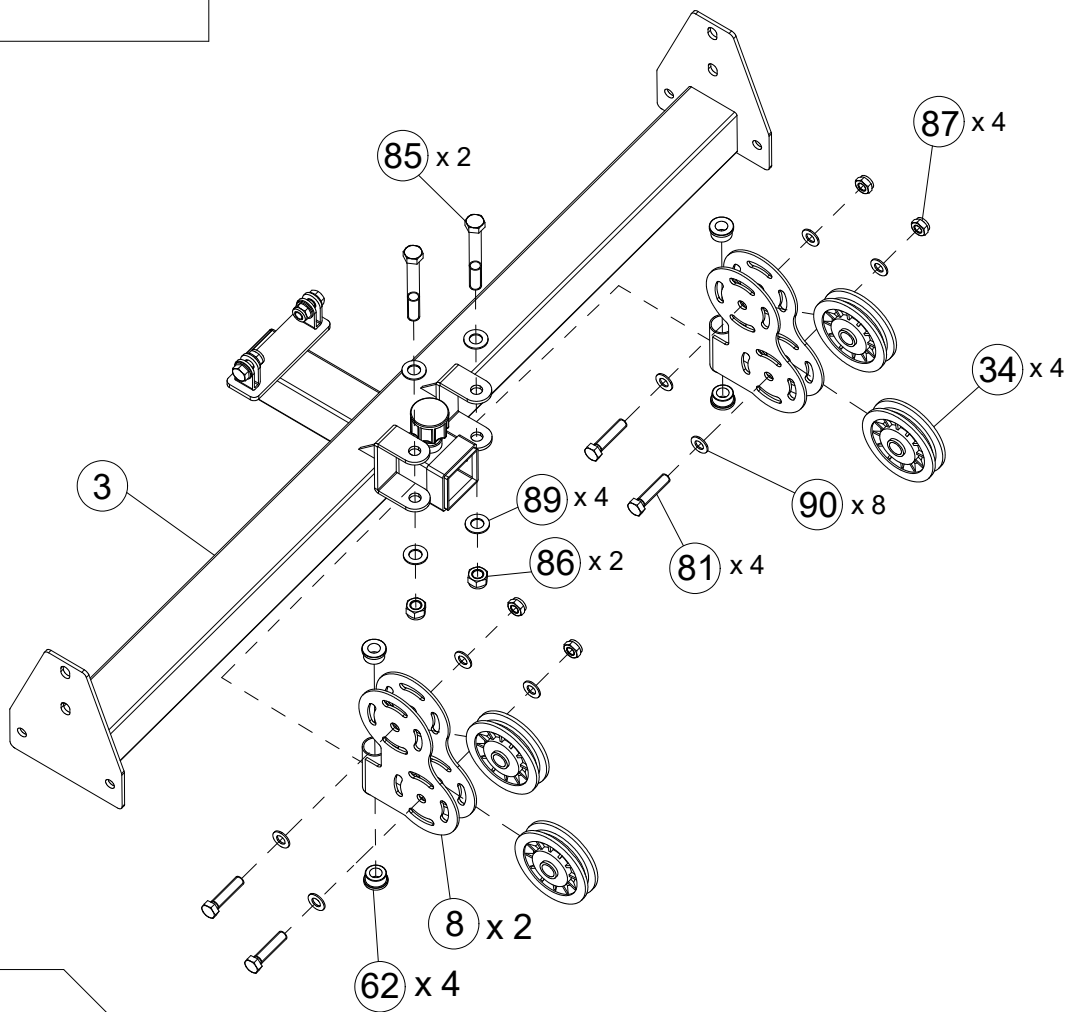

81



x 6 M10x45

87



x 6 M10

90



x12 Ø10

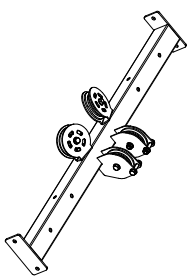
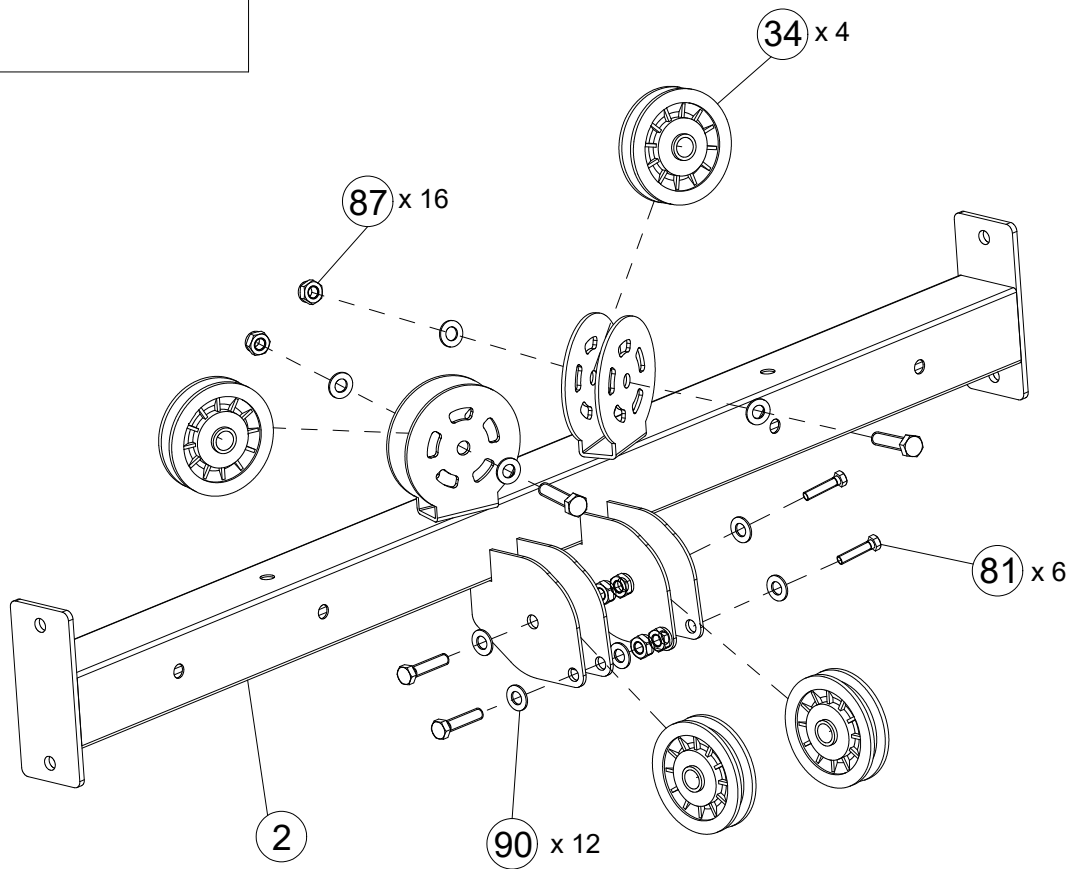

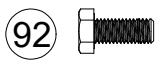

x 4 M10x25

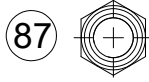

x 16 M10

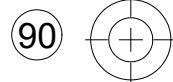

x 36 Ø10



x 16 M10x80

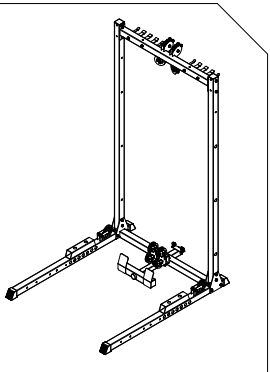
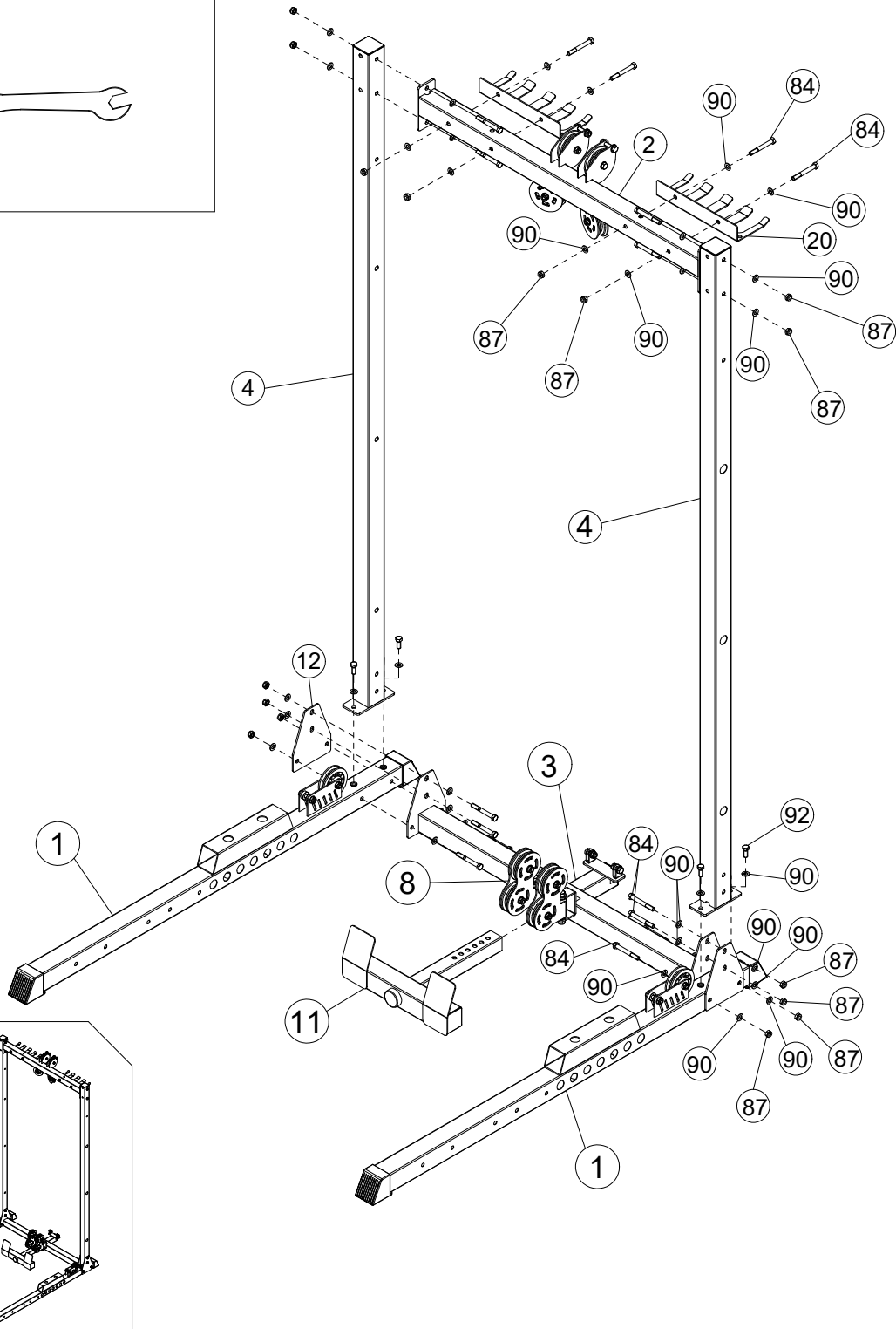

84  x 12 M10x80

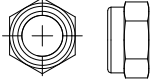
87  x 12 M10

90  x 48 Ø10

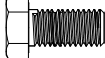

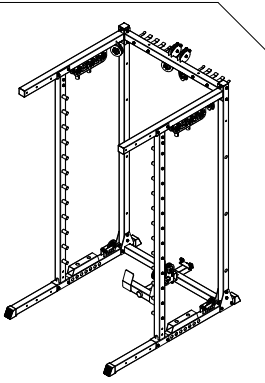
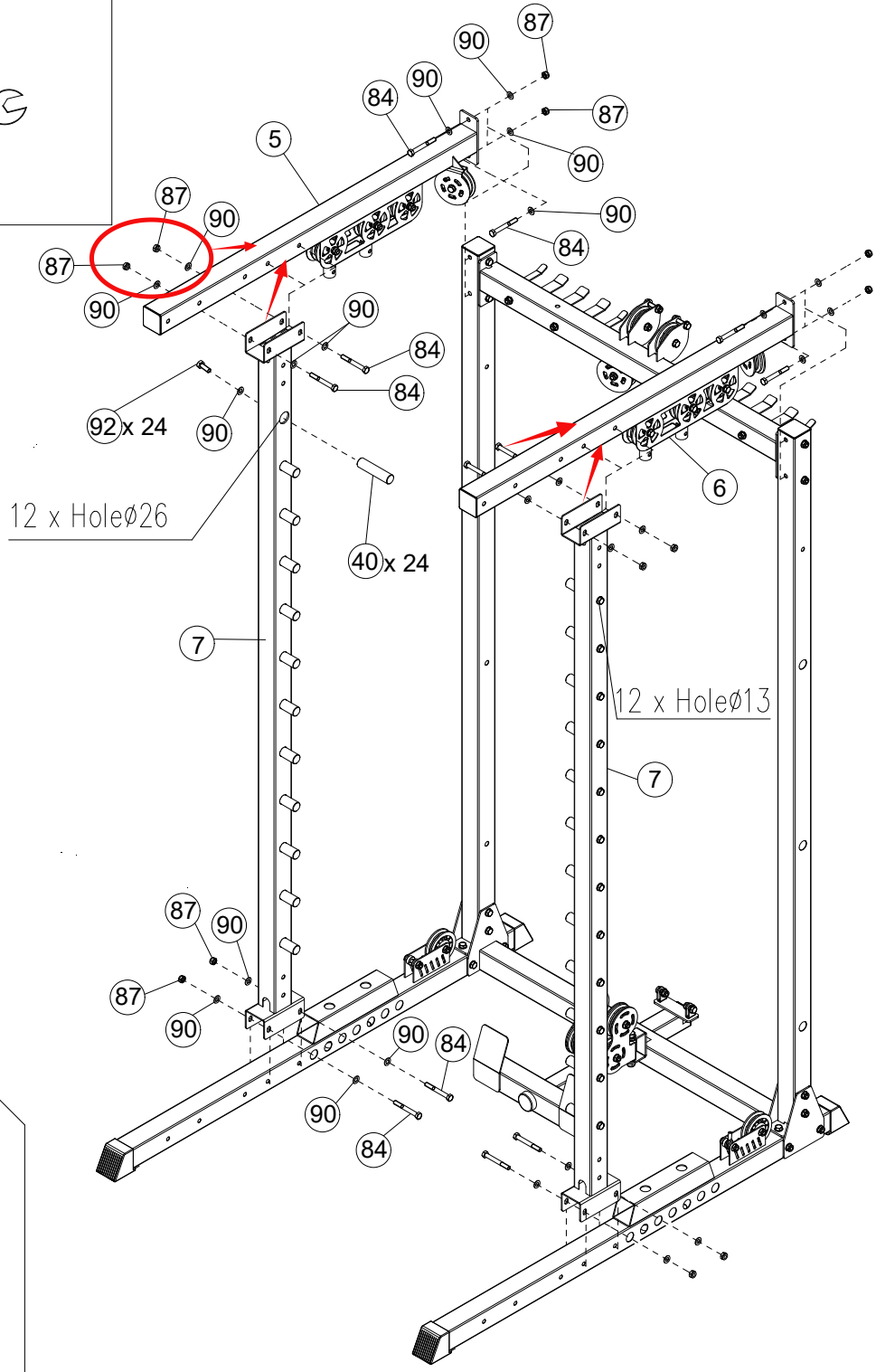
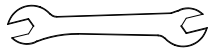
92  x 24 M10 x25





Skip to next page: Use this page only as a reference for future steps where parts align for part #'s 5 and 6

- 81  x 2 M10x45

83  x 6 M10x70

87   x 16 M10
- 84  x 8 M10x80

90   x 32 Ø 10

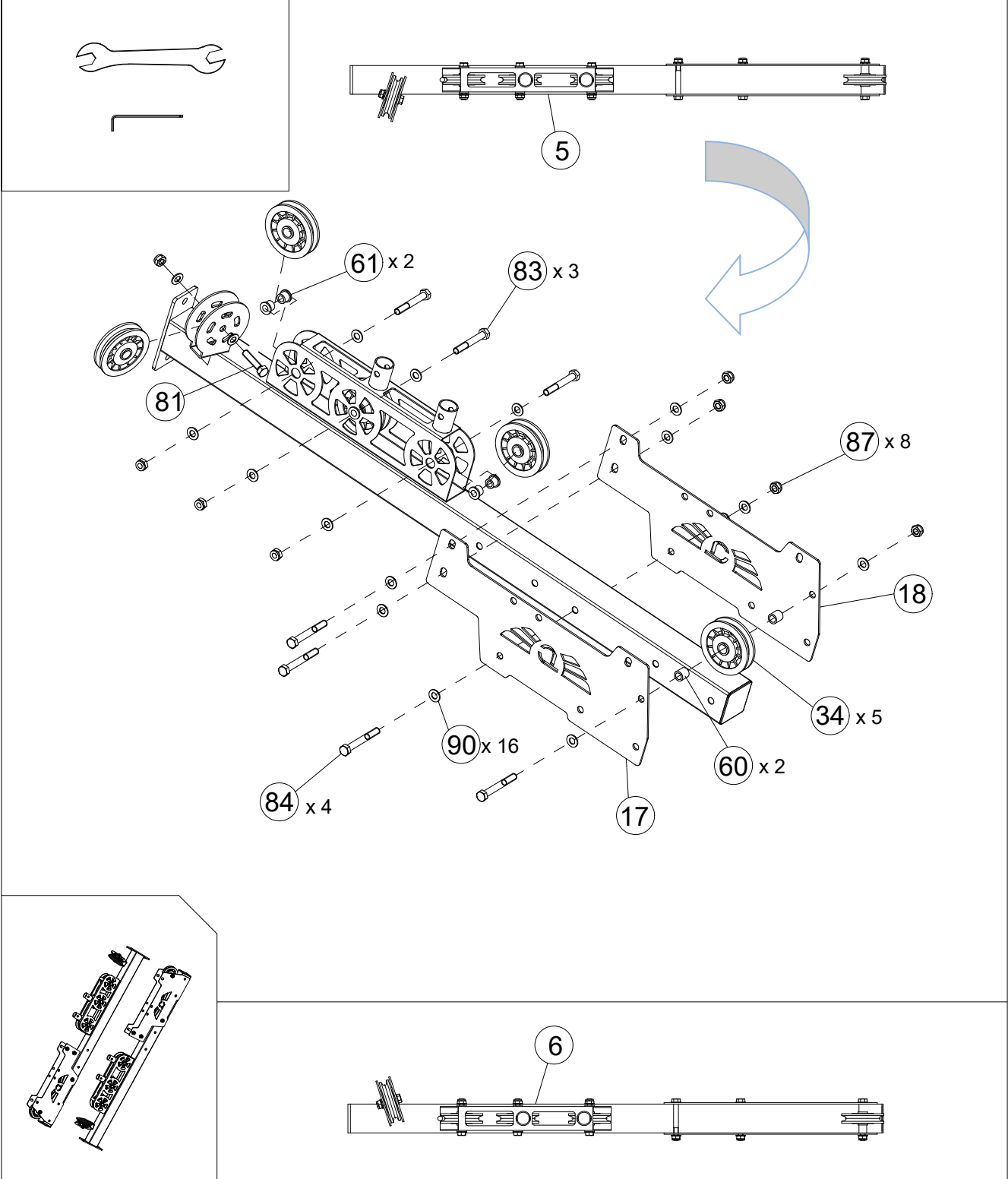

81



x 4 M10x45

87



x 16 M10

90



x 32 Ø10

84



x 12 M10x80



x 2

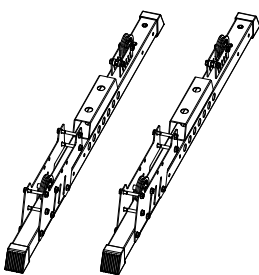
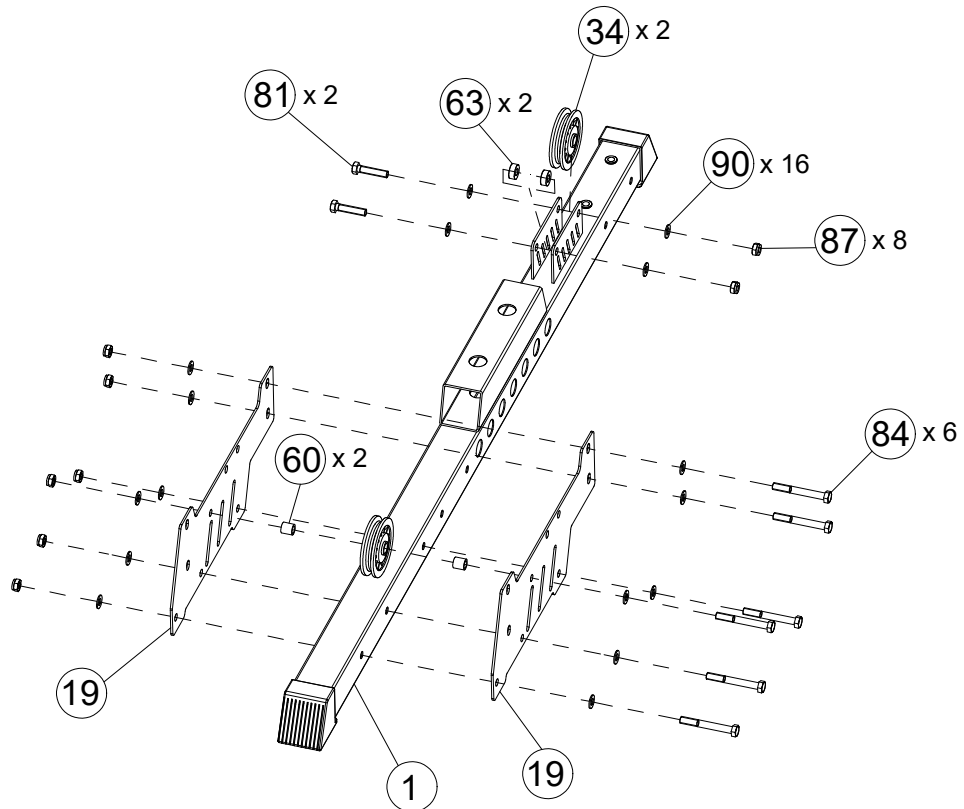

84

x 16 M10x80

87



x 12 M10

90



x 64 Ø10

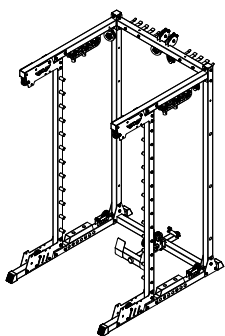
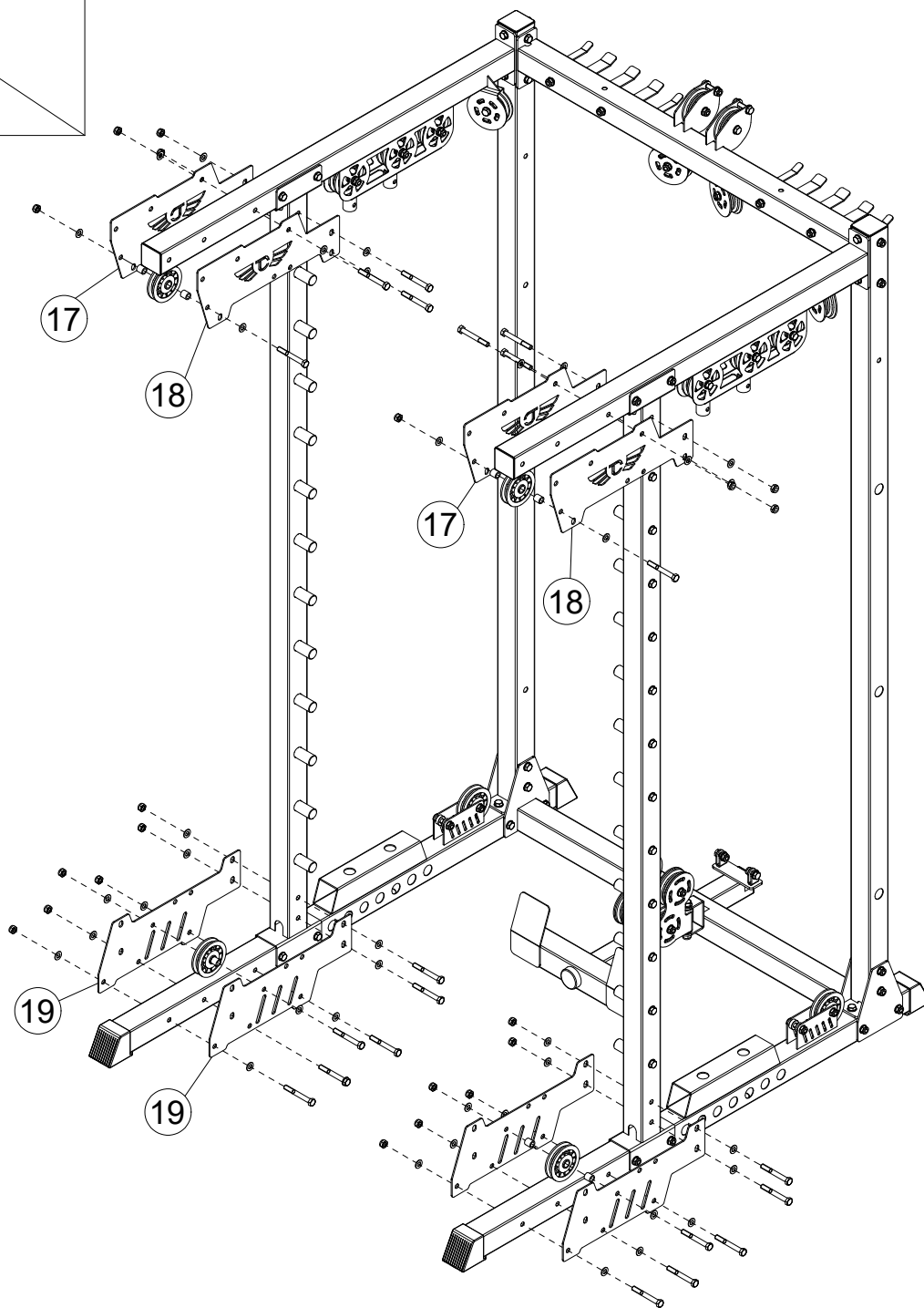
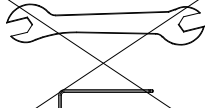

94



x 2 M12X20

96



x 2 M10X20

89

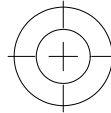

x 2 Ø12

95



x 8 M10X90

87



x 8 M10

90

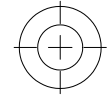



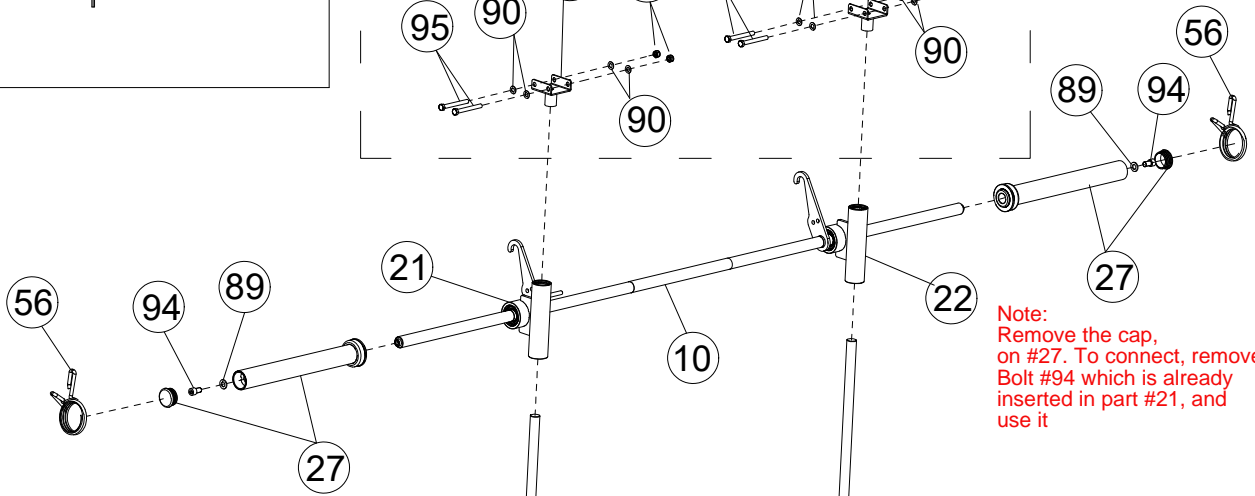
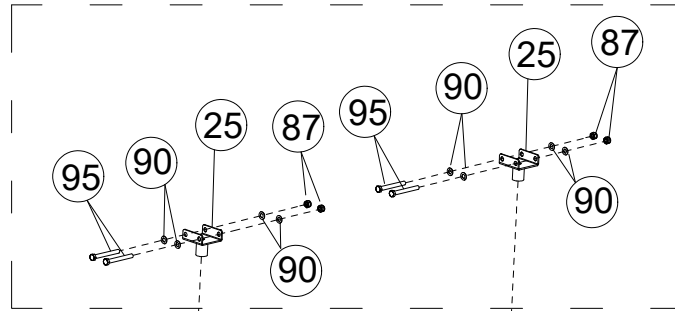
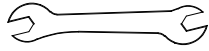

x 18 Ø10

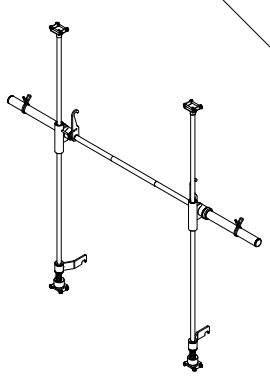
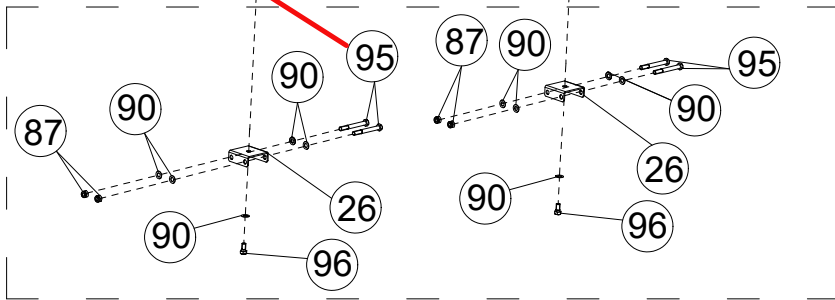

Note: Remove the cap, on #27. To connect, remove Bolt #94 which is already inserted in part #21, and use it

Note: Connect only one Bolt #95 on the bottom front hole first on each side. This will allow you to pivot part # 16 forwards to be able to slide part #10 onto the guide rods



- 95  x 8 M10X90
- 87  x 8 M10
- 90  x 16 Ø10

Note: These are not additional bolts.
 These are the same bolts from the previous page

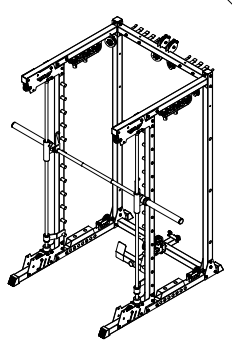
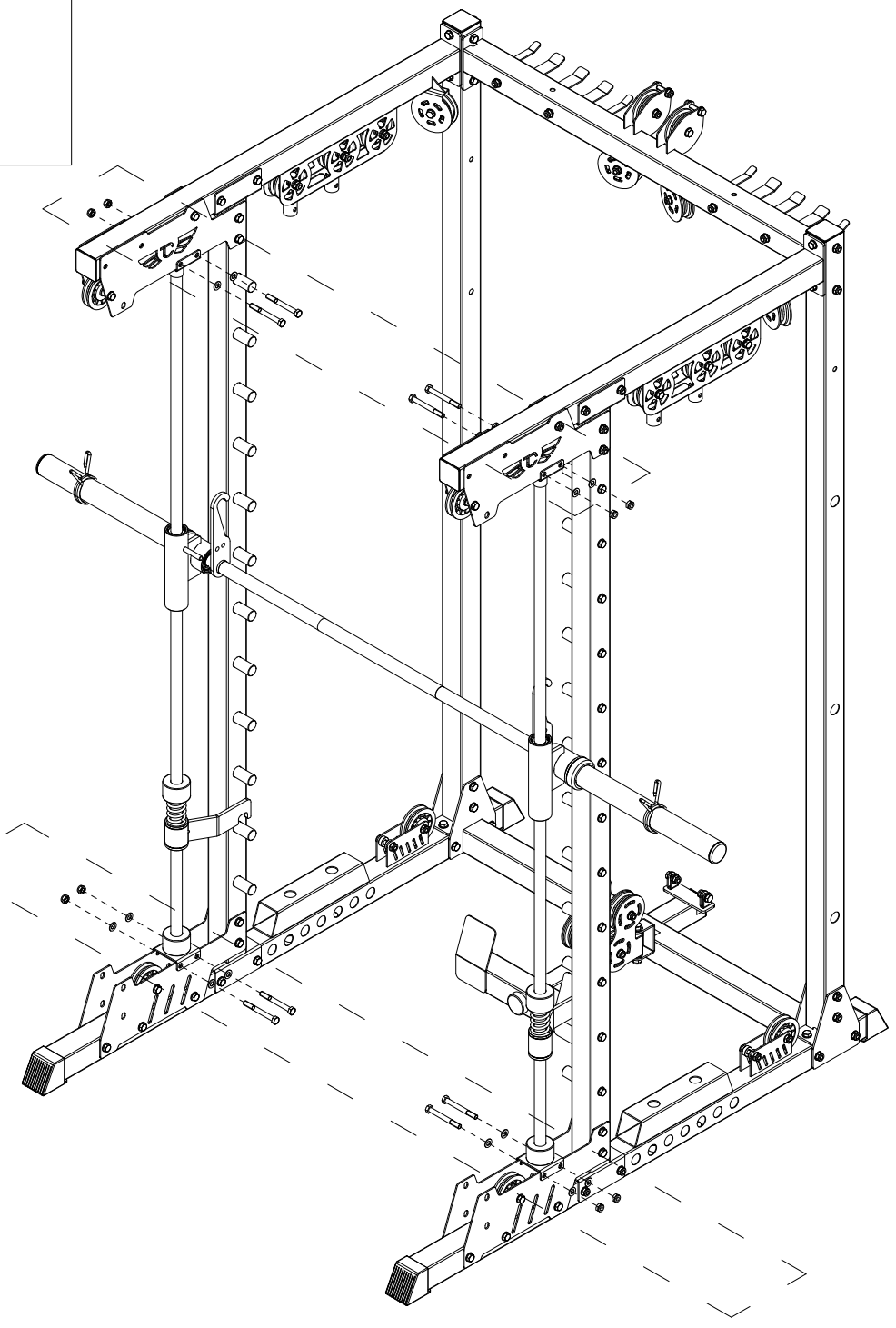

81



x 4

M10x45

87



x 4

M10

90



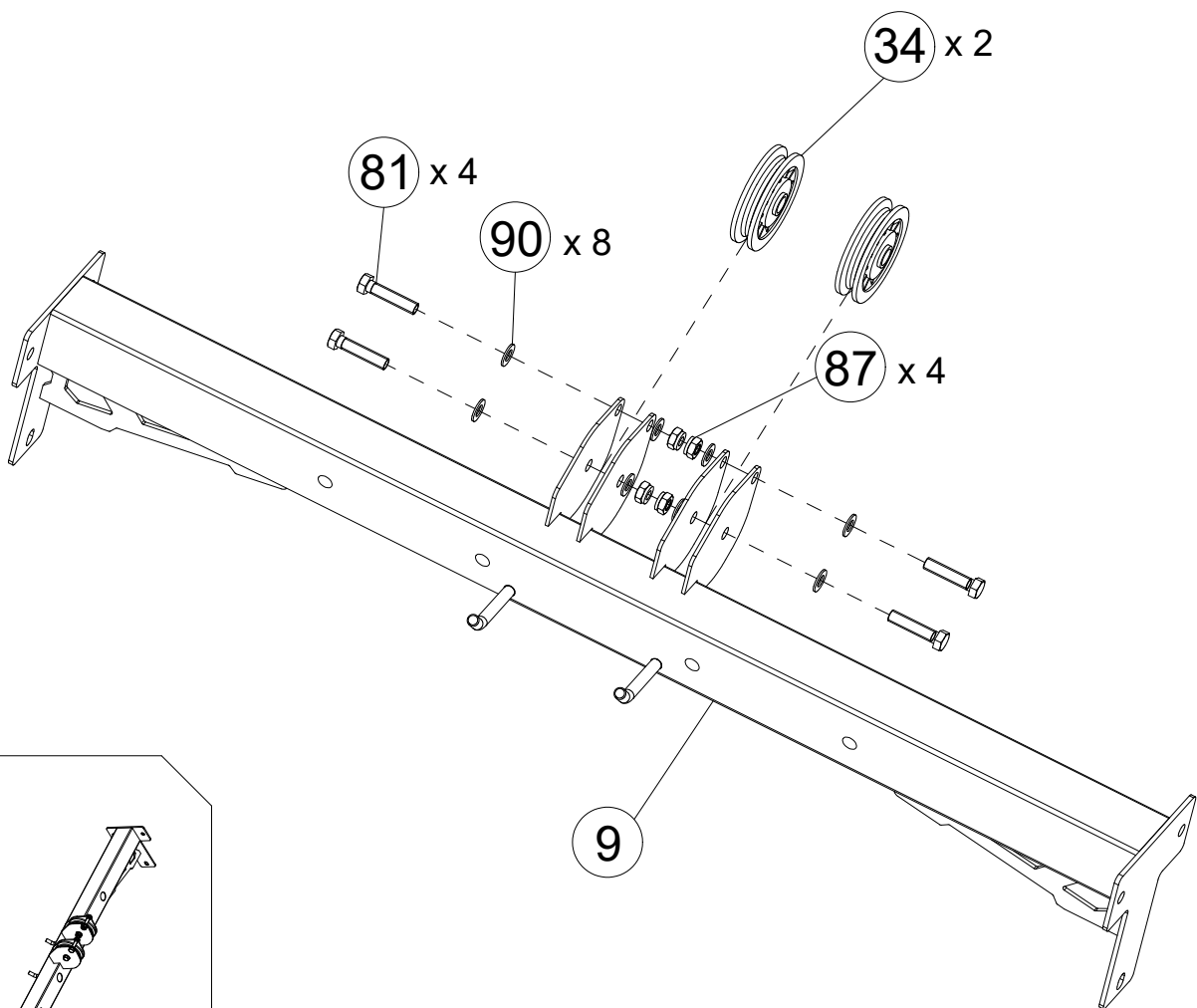
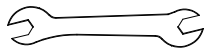

x 8

Ø10



84  x 8 M10x80

87  x 14 M10

89  x 4 Ø12

93  x 4 M12X25

90  x 28 Ø10

97  x 6 M10x85

103  x 4 Ø12

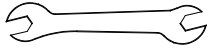

4 x Hole-Ø26

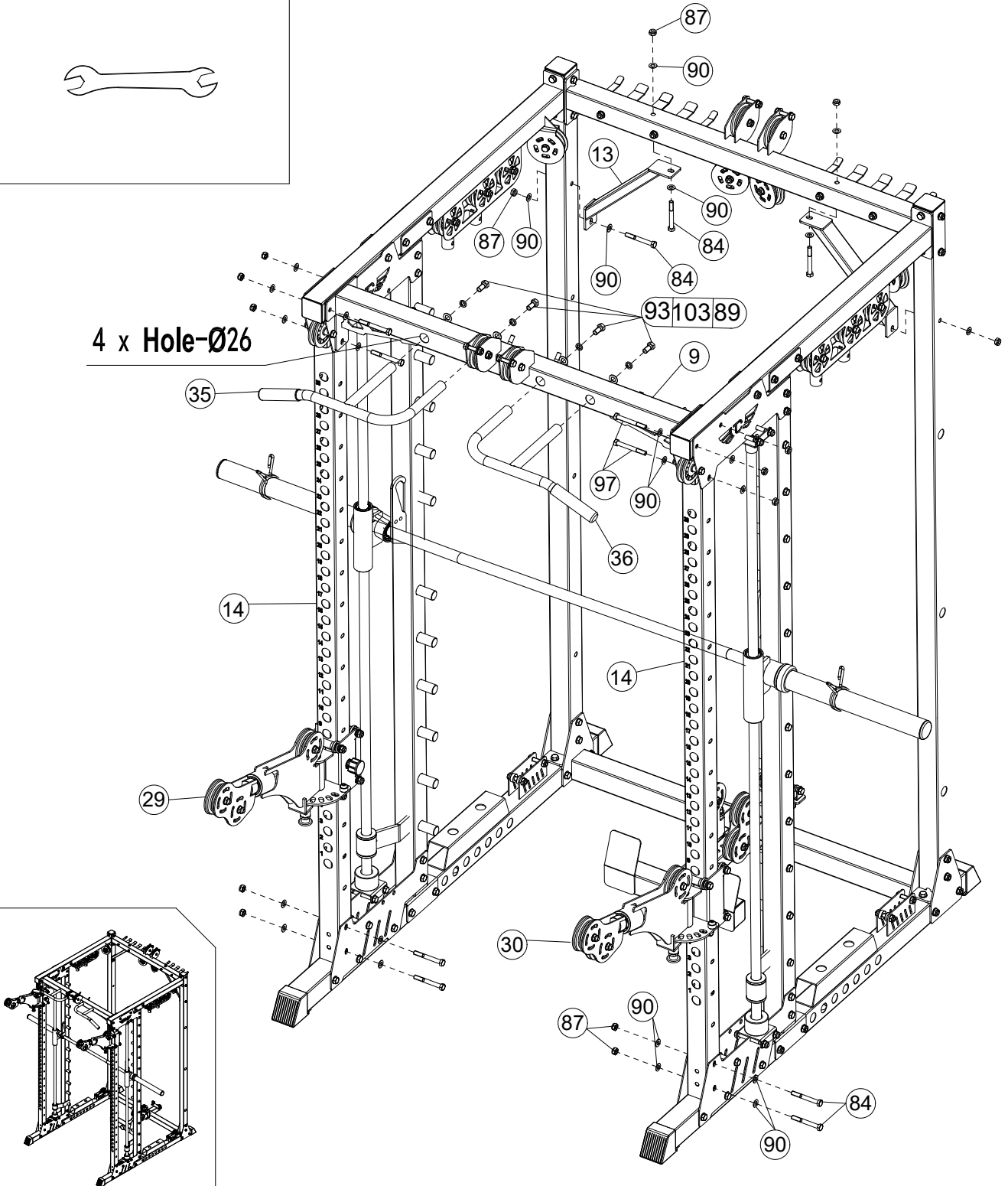

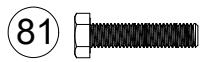

x 4 M10x45

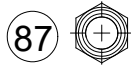

x 6 M10

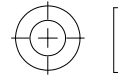

x 12 ? 10

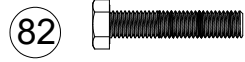

x 2 M10x50

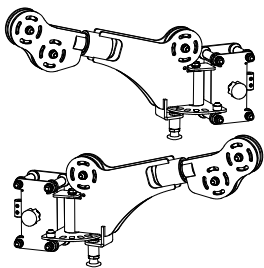
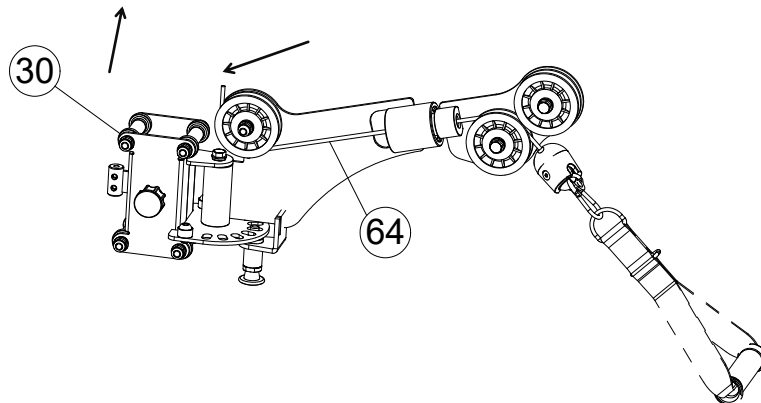
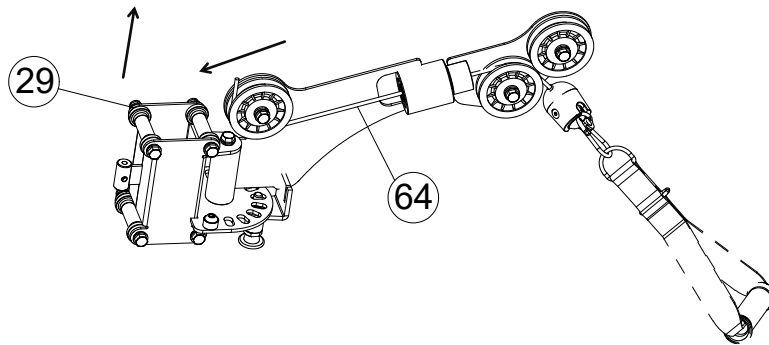
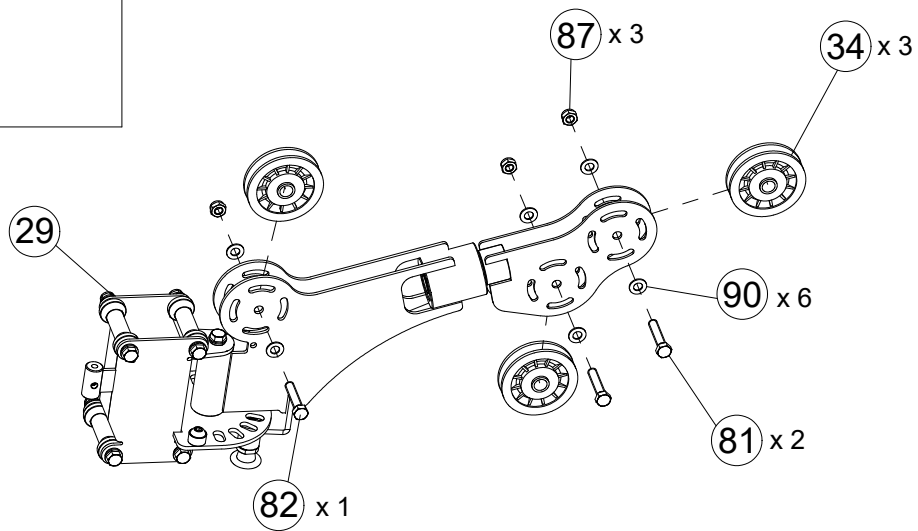

84  x 8 M10x80

87  x 14 M10

89  x 4 Ø12

93  x 4 M12X25

90  x 28 Ø10

97  x 6 M10x85 **Note: #97 should have already been installed on page 21**

103  x 4 Ø12

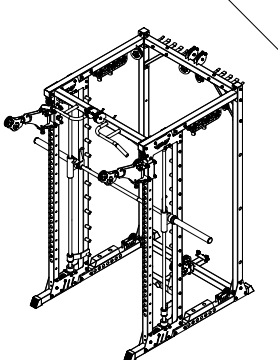
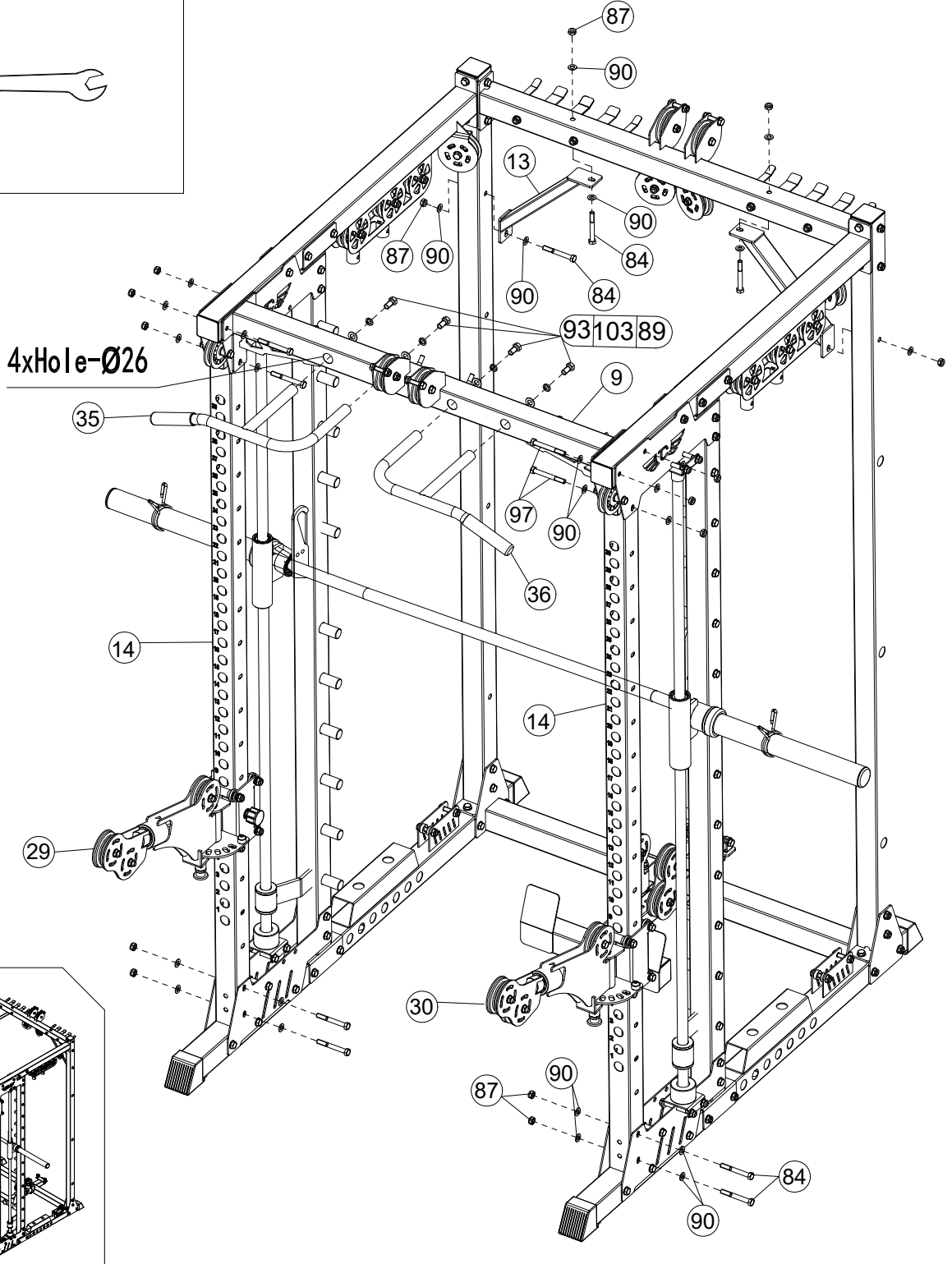

93 x 6 M12X25

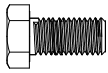

89 x 6 Ø12

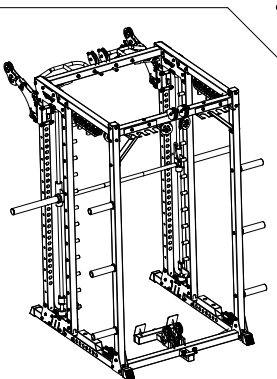
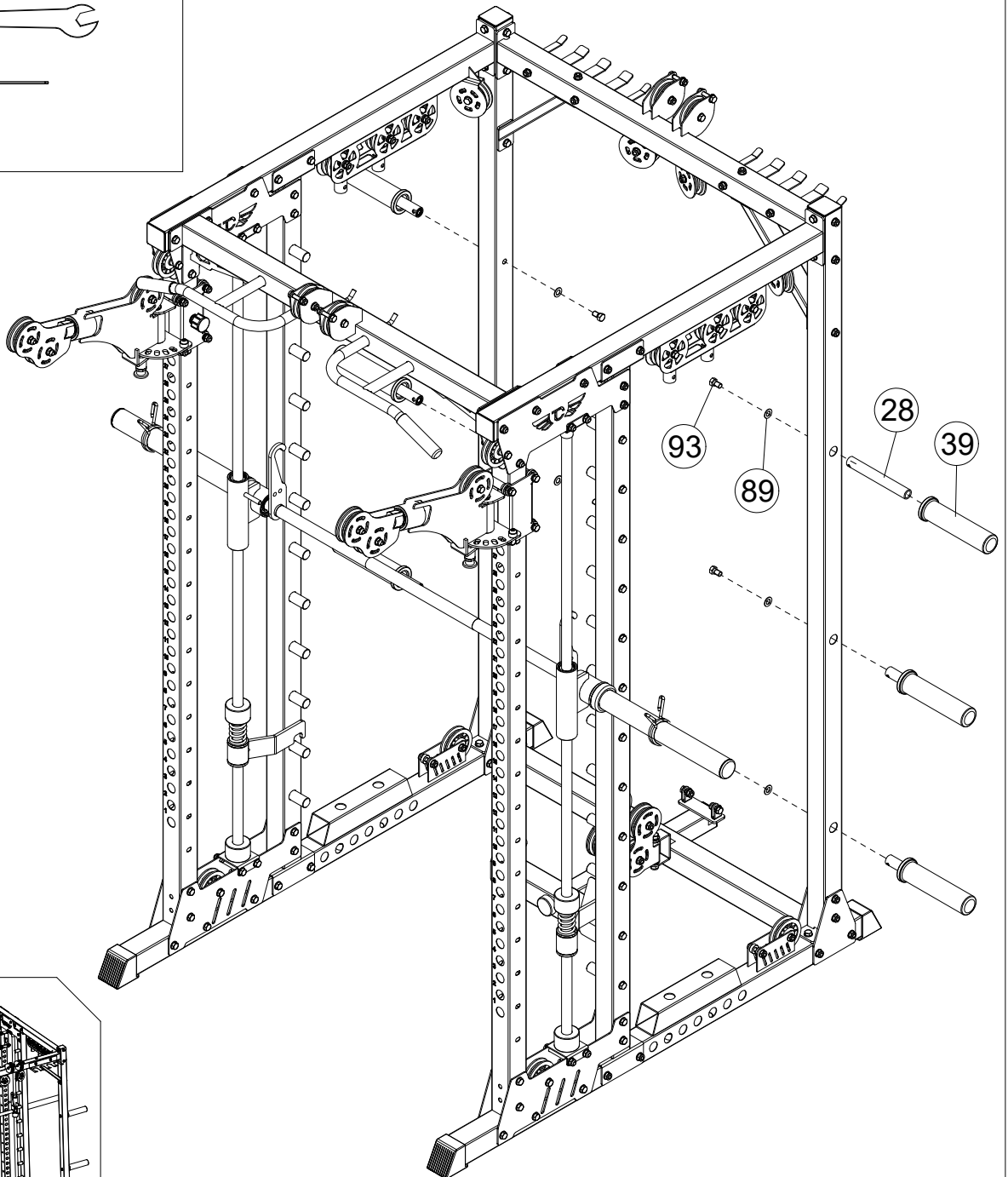
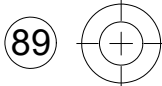

81



x 2 M10x45

87



x 6 M10

90



x 4 Ø 10

98



x 4 M8x45

99



x 4 M8

100



x 8 Ø 8

101



x 2 M12

102



x 2 Ø 13xØ 37

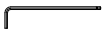
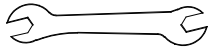

70KG/154lbs

Indicates which weight stack version you have

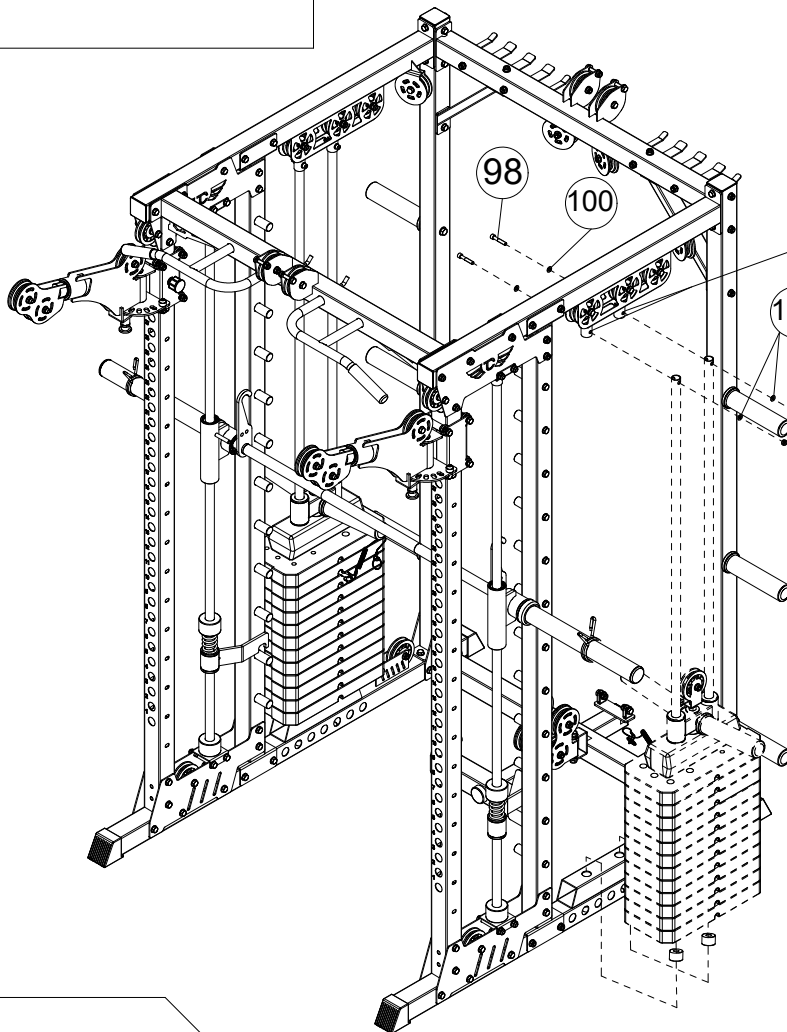
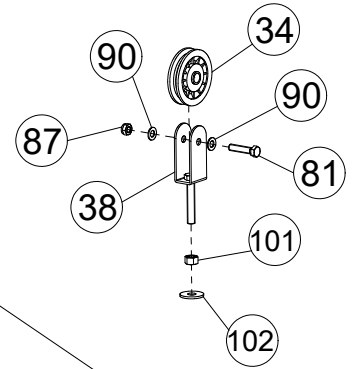

Hole-Ø10

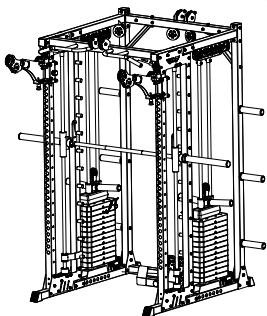
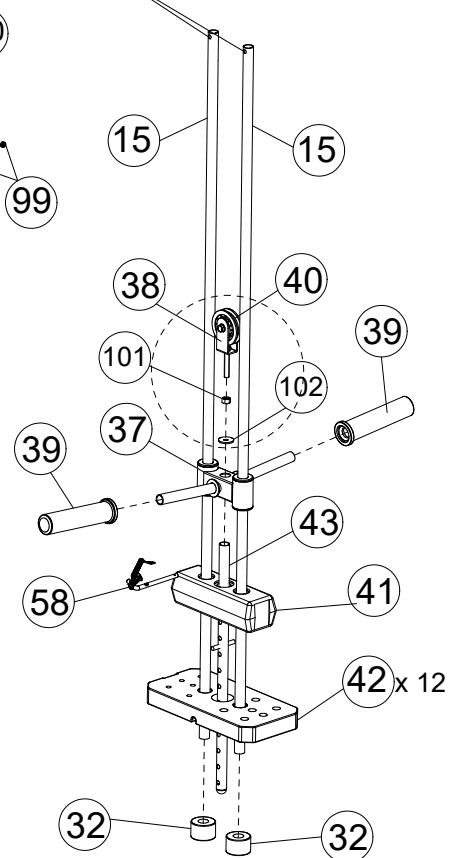

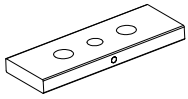

121

285x100X25

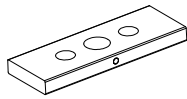

122

285x100X25



123

∅ 25x696 (23+1)



125

∅ 10



126

∅ 25



32

∅ 25



90KG/198lbs

Indicates which weight stack version you have

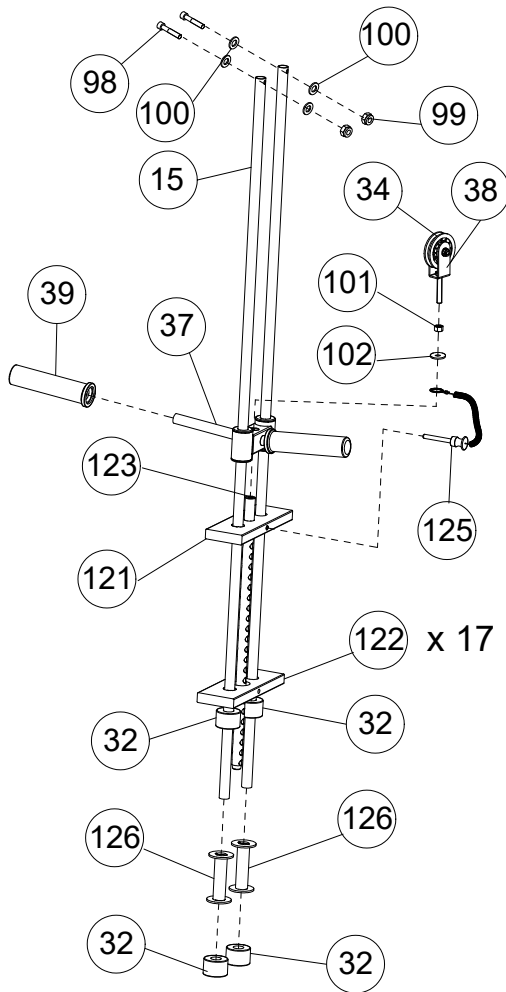

98 x4 M8x45

99 x4 M8

100 x8 ∅ 8

101 x2 M12

102 x2 ∅ 13x∅ 37

15 x 4 32 x (4+4)

37 x 2 38 x 2



39 x 4 121 x 2

122 x 17 125 x 2

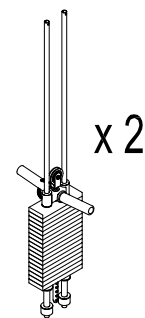
123 x 2 126 x 4





80  x 4 M6x45

88   x 4 M6

91  | x 8 Ø6

81  x 8 M10x45

87   x 8 M10

90  | x 16 Ø10

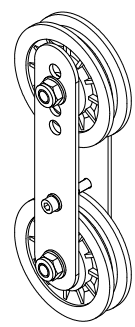
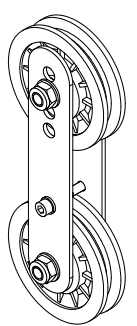
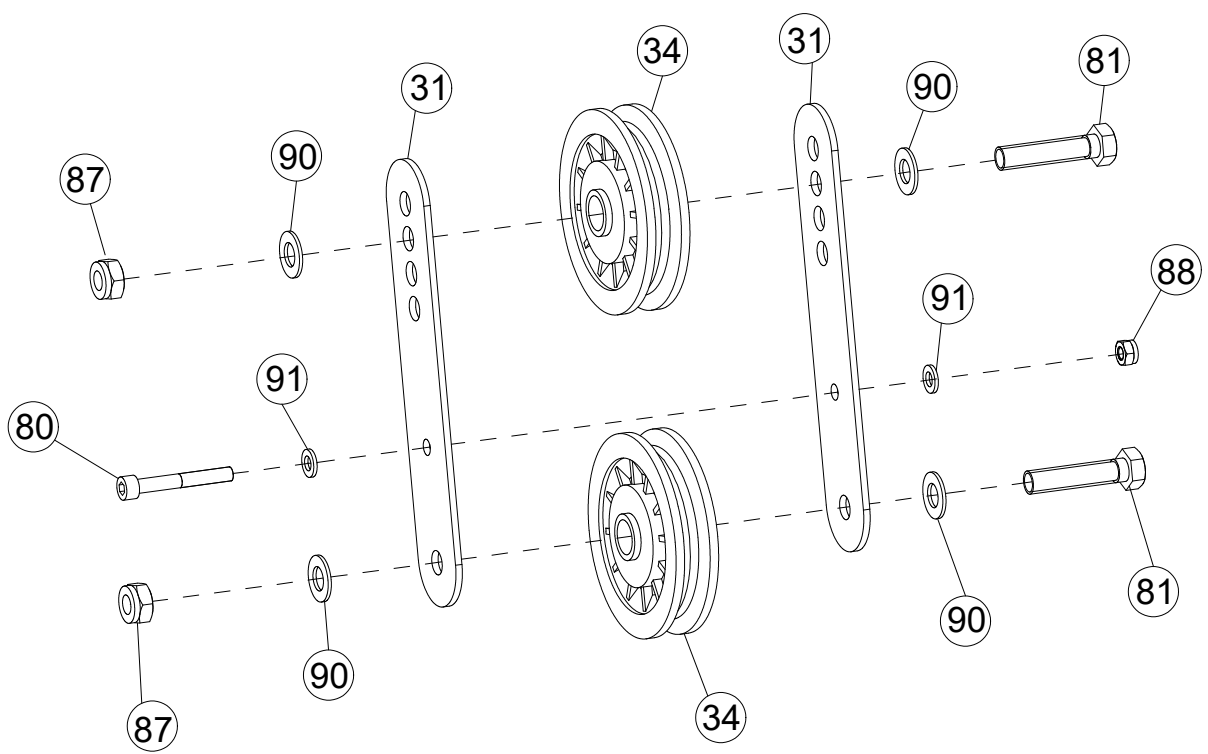

x 4

Give yourself slack in the Blue cable to make it easier to route the cables, by raising your top plate and inserting your weight stack pin in one of the weight stack holes to keep it elevated as you run the cables

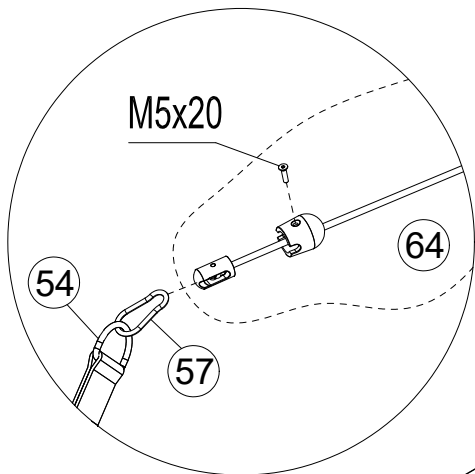

PRO TIP:

To give yourself slack to make the cable easier to run, raise the Head Plate (18), and insert the Weight Stack Pin (52), to keep it in place.

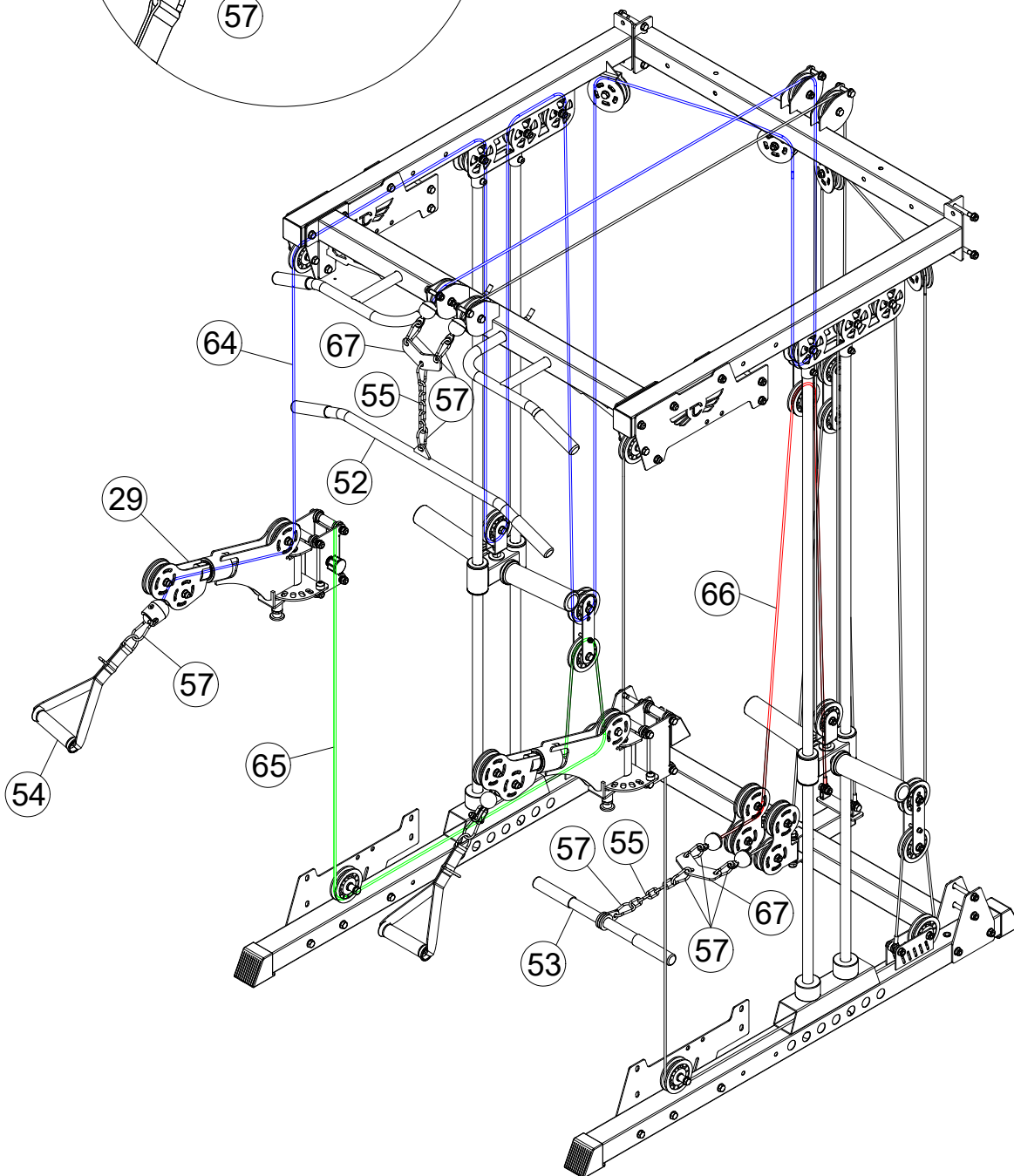

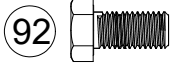

x 2

M10 x25

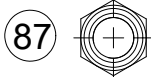

x 2

M10



x 4

Ø10

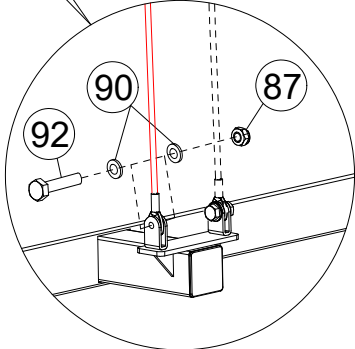
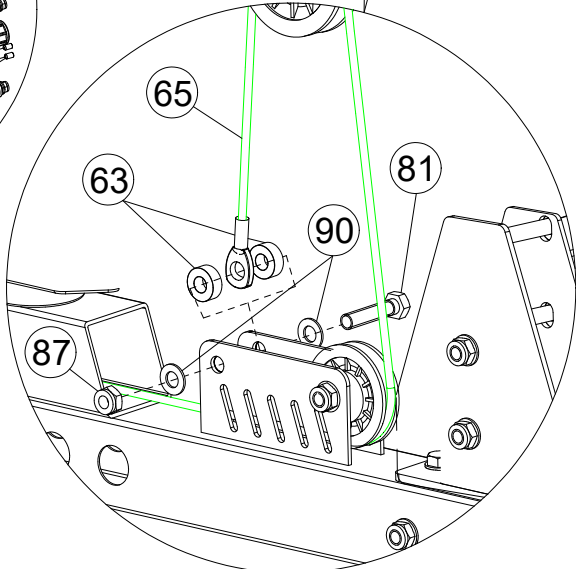
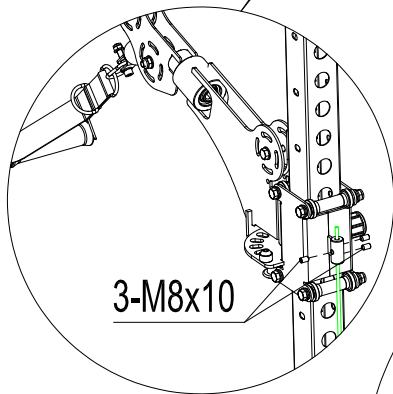
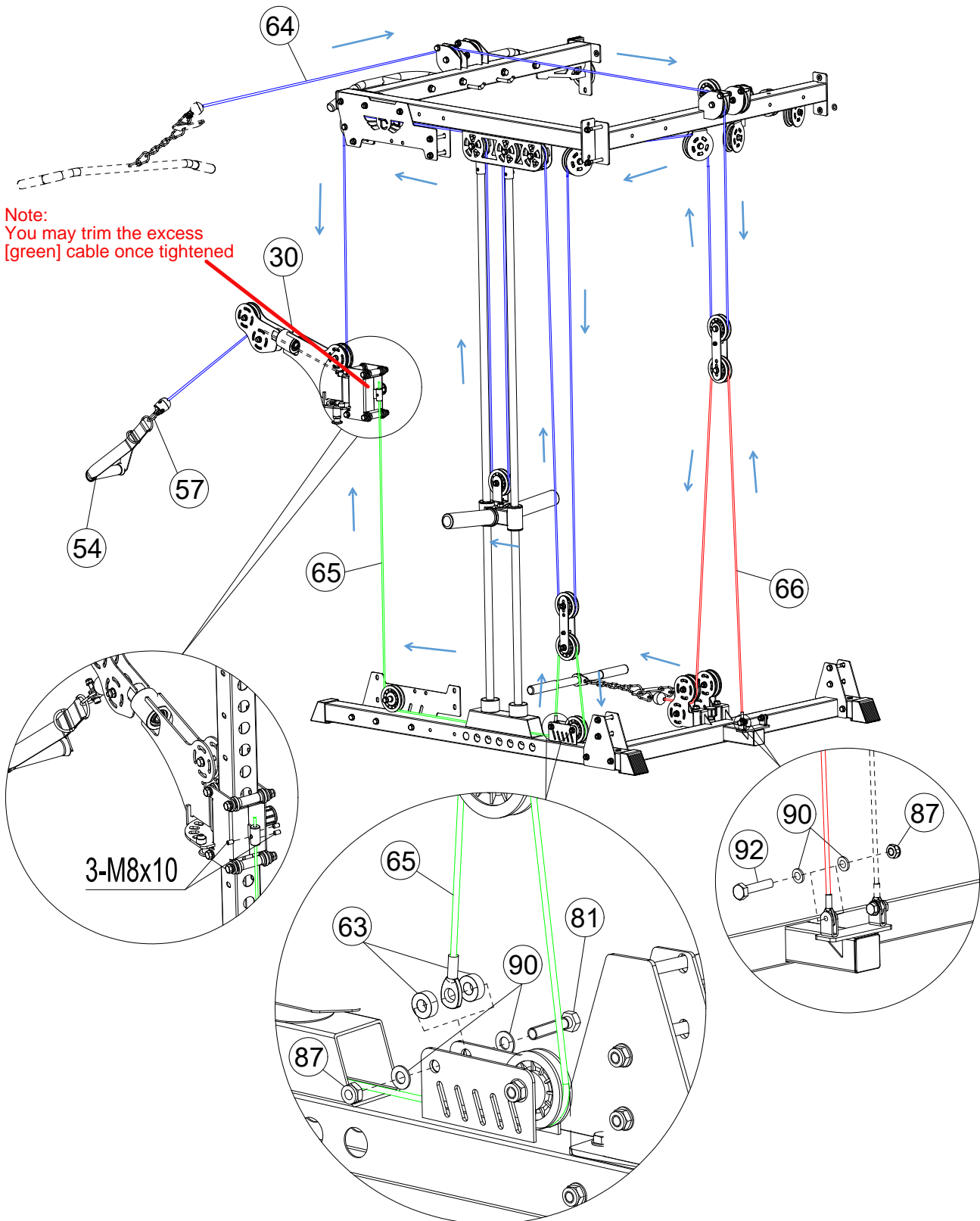

V. EXERCISE GUIDE

⚠ PLEASE NOTE:

Before beginning any exercise program, consult your physician. This is important especially if you are over the age of 45 or individuals with pre-existing health problems.

The pulse sensors are not medical devices. Various factors, including the user's movement, may affect the accuracy of heart rate readings. The pulse sensors are intended only as an exercise aid in determining heart rate trends in general.

Exercising is a great way to control your weight, improve your fitness and reduce the effect of aging and stress. The key to success is to make exercise a regular and enjoyable part of your everyday life.

The condition of your heart and lungs and how efficient they are in delivering oxygen via your blood to your muscles is an important factor to your fitness. Your muscles use this oxygen to provide enough energy for daily activity. This is called aerobic activity. When you are fit, your heart will not have to work so hard. It will pump a lot fewer times per minute, reducing the wear and tear of your heart.

So as you can see, the fitter you are, the healthier and greater you will feel.

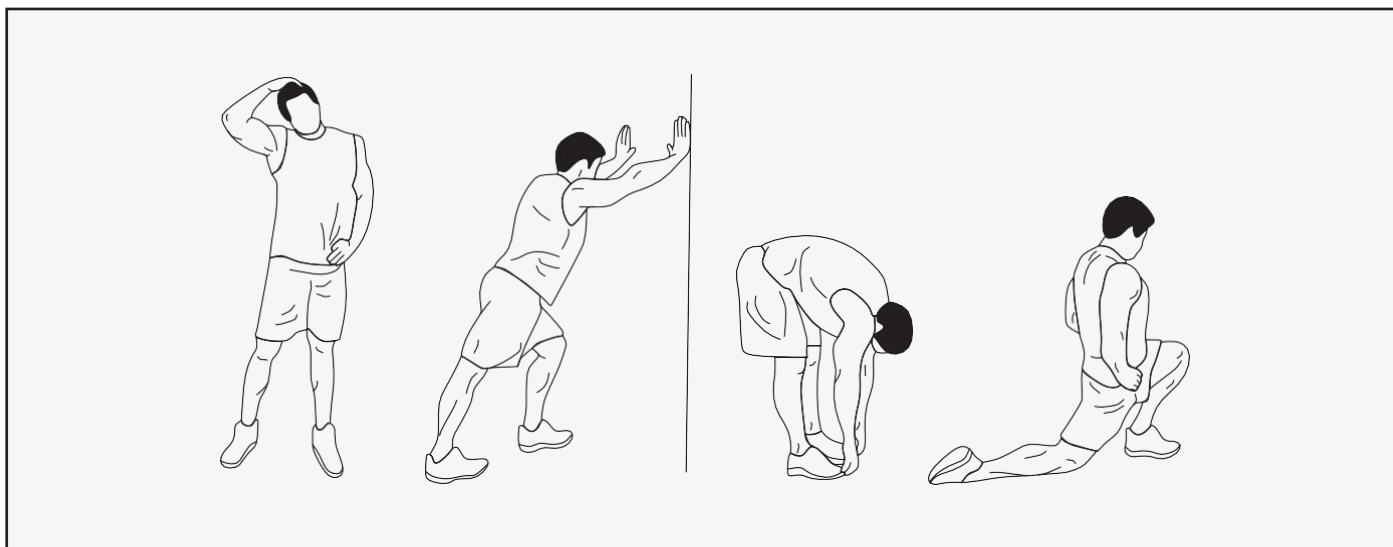

WARM UP

Start each workout with 5 to 10 minutes of stretching and some light exercises. A proper warm-up increases your body temperature, heart rate and circulation in preparation for exercise. Ease into your exercise.

After warming up, increase the intensity to your desired exercise program. Be sure to maintain your intensity for maximum performance. Breathe regularly and deeply as you exercise.

COOL DOWN

Finish each workout with a light jog or walk for at least 1 minute. Then complete 5 to 10 minutes of stretching to cool down. This will increase the flexibility of your muscles and will help prevent post-exercise problems.

WORKOUT GUIDELINES

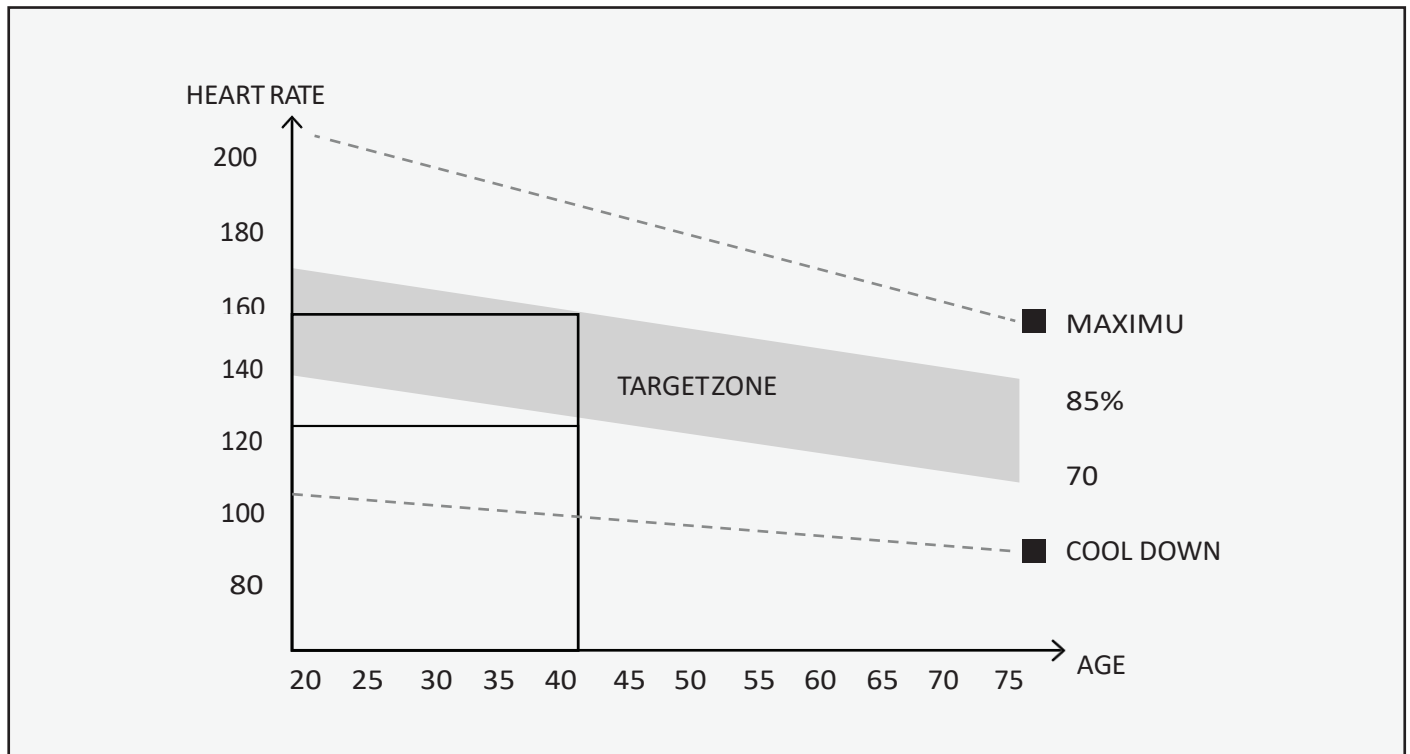

! This is how your pulse should behave during general fitness exercise. Remember to warm up and cool down for a few minutes.

VI. MAINTENANCE

MAINTENANCE METHOD:

To extend the service life of the device, the parts must be lubricated on time. The product has been initially lubricated before leaving the factory, but lubrication is required between the guide rod and the weight plate over time.



NOTE: Silicon oil/spray is recommended for lubrication.

1. Pulley and wire ropes should be regularly checked for signs of wear.
2. Check and adjust the tension of the wire rope regularly.
3. Check all moving parts regularly. If there is a damaged part, stop using the device immediately and contact the store.
4. Ensure all bolts and nuts are fully fixed and re-tighten them when it is loose.
5. Check the welding for cracks.
6. Failure to perform routine maintenance may cause personal injury or equipment damage.
7. Ensure any handle attachments are fully secured before use to prevent from injury.