

Important Safety Instructions	1	Replacing the Console Assembly / Console Shroud	7
Specifications	1	Replacing the Drive Belt	8
Care of the Fitness Machine	2	Removing the Treadle Assembly	10
Walking Belt and Deck Lubrication	2	Replacing the Walking Deck	14
Walking Belt Adjustment	2	Replacing the Front Roller	17
Walking Belt Electrostatic Reduction	3	Replacing the Walking Belt	19
Troubleshooting	4	Replacing the Dependency	24
Console Service/Setup Mode	5	Replacing the Main Drive Assembly	26
Replacing the Console Top with Electronics Assembly	6	Replacing the Speed Sensor Cable	30

Important Safety Instructions - Before servicing or using this equipment, obey the following warnings:

! This icon means a potentially hazardous situation which, if not avoided, could result in death or serious injury. Read and understand all Warnings on this machine.

- Read and understand the Service Manual before working on the machine. Failure to obey the instructions and safety warnings could cause injury to the service technician or bystanders.
- Keep bystanders and children away from the product being serviced at all times.
- Make sure that the repair is done in an appropriate work space away from foot traffic and exposure to bystanders.
- Disconnect all power (batteries) and allow to sit for 5 minutes before you service this machine.
- Some components of the equipment can be heavy or awkward. Enlist the service of a second person when you do maintenance steps involving these components. Do not try to do heavy or awkward steps on your own.
- Use only replacement parts and hardware that are supplied or approved by Nautilus. Failure to use Nautilus-approved replacement parts can adversely affect the safety and functionality of the equipment creating a risk to users.
- Be sure that all warning stickers and instructional placards applied to the product stay present and in good condition when doing maintenance or replacing components. If necessary request replacement warning stickers or placards from Nautilus® customer service.
- Do not try to change the design or functionality of the machine being serviced as this can adversely effect user safety.
- Do not use the machine until all shrouds, instructions, warning labels and correct functionality have been verified and tested for correct performance.

Nautilus, Inc., (800) NAUTILUS / (800) 605-3369, www.NautilusInc.com - Customer Service: North America (800) 605-3369, tcinquiry@nautilus.com | outside U.S. +01-360-859-5180, technics-APLA@nautilus.com | © 2011 Nautilus, Inc. All rights reserved. ™ and ® indicate a trademark or registered trademark. Nautilus, Inc. (www.NautilusInc.com) trademarks include NAUTILUS®, BOWFLEX®, SCHWINN® and UNIVERSAL® and respective logos. Other trademarks are the property of their respective owners.

Specifications

Assembled Weight: approx. 163 lbs. (74 kg)
 Power Requirements: 2 AA batteries (not included)
 Operational Voltage: 1.0 - 3.3VDC

Serial Number

AAAAAAA Nautilus® part number (SKU)
 BBB Vendor Code
 PPPPPP Purchase Order Number
 LL Purchase Order Line Number
 CCCCCC Unique Identifier

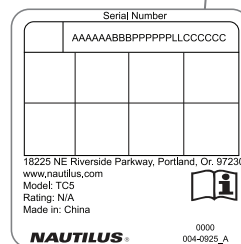
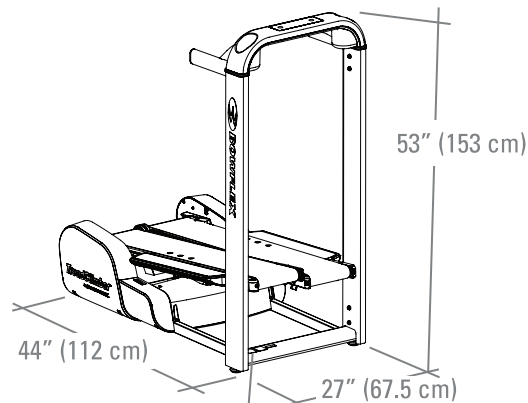

Care of the TreadClimber® Fitness Machine

⚠ DANGER To reduce the risk of electrical shock, always remove the batteries and wait 5 minutes before cleaning, maintaining or repairing this machine.

- ⚠** Read all maintenance instructions fully before you start any repair work. In some conditions, an assistant is necessary to do the necessary tasks. Equipment must be regularly examined for damage and repairs. The owner is responsible to make sure that regular maintenance is done. Worn or damaged components must be replaced immediately or the equipment removed from service until the repair is made. Only manufacturer supplied components can be used to maintain and repair the equipment.
- ⚠** This product, its packaging, and components contain chemicals known to the State of California to cause cancer, birth defects, or reproductive harm. This Notice is provided in accordance with California's Proposition 65. If you would like additional information, please refer to our Web site at www.nautilus.com/prop65.

- Daily:** Before each use, inspect for loose, broken, damaged, or worn parts. Do not use the machine if any of these conditions exist. Use a dry cloth to wipe off any perspiration after each use.
- Weekly:** Check for smooth roller operation. Clean the machine to remove dust, dirt, or grime. Clean the top of the belt with a damp, soapy cloth and wipe carefully and thoroughly with a dry cloth. Do not let any liquid below the belts or into the Base Frame.
- Monthly:** Make sure all bolts and screws are tight. Tighten if necessary.
NOTICE: Do not clean with a petroleum based solvent or an automotive cleaner. Be sure to keep the Console free of moisture.

Walking Belt and Deck Lubrication

The TreadClimber® fitness machine is equipped with a low maintenance deck and belt system. Belt friction can affect the function and life of the machine. For the best results lubricate the Treadles periodically with a silicone lubricant, using the following instructions:

1. Remove the batteries from the machine.
2. Carefully lift each belt and apply silicone lubricant in the center of the Treadle deck along the entire reachable length of the deck. Apply 0.15 to 0.25 oz. of the lubricant on the deck underneath each belt.
NOTICE: Always use a 100% pure silicone lubricant. Do not use a degreaser like WD-40® as this could seriously impact performance.
Note: The Walking Belts may need to be loosened to allow for access during lubrication. Consult the "Adjusting the Walking Belts" procedure if necessary.
3. Stay to one side of the machine and grasp the handlebars for support.
4. With one foot push the nearest belt toward the back of the machine at a very slow speed for approximately 15 seconds. Do not step on any excess lubricant, grease, or oil while pushing the belt.
5. Take care to clean up any excess lubricant from the Treadles. We also recommend a periodic inspection of the Treadle surfaces below the belts. If the decks appear worn, contact a TreadClimber® Representative (refer to the Contacts section of this manual).

⚠ To decrease the possibility of slipping, be sure the Treadle area is free from grease or oil. Clean off any excess oil from the machine surfaces.

Use the following timetable as a guide to lubricate the decks:

- Light user (fewer than 3 hours / week): every 3 months
- Moderate user (3-5 hours / week): every 2 months
- Heavy user (more than 5 hours / week): every month

We recommend that you use the following:

- Lube-N-Walk® Treadmill Lubrication Kit (available from www.bowflex.com or your local specialty fitness dealer)
- 100% pure silicone spray (available at most hardware and auto parts stores)

Walking Belt Adjustment

The walking belts need to be adjusted if they are out of center enough to cause a rubbing or scraping sound. Adjustments can be made at the Front Roller of each Treadle (Item A).

Adjusting the Walking Belts – While operating the machine, notice where the belts run on each Treadle. The Walking Belt Adjustment Bolts are on the front end of each Roller. If the belt is tracking too far to the right, use a 5 mm hex wrench to turn the right walking belt adjustment bolt clockwise on that belt in a half turn increment. Secure the hex wrench and operate the walking belts for approximately 30 seconds, noticing if the walking belt is adjusted. Repeat as necessary until adjusted.

If the belt tracks too far to the left, do the same thing on the left walking belt adjustment bolt.

Note: Do not turn the bolts counterclockwise when you adjust the belt alignment.

Belt Tension Adjustment – Check the belt tension only when the machine is secured. From the belt's midpoint, a correctly tensioned belt should only have an inch of give. To check, pull the belt upward at its midpoint and measure the distance to the deck. If the distance is more than an inch, the belt is loose. To tighten, turn both Walking Belt Adjustment Bolts clockwise one-half a turn equally and check tension again. Repeat this step if necessary.

Note: Bolts are turned counterclockwise equally to decrease belt tension.

Walking Belt Electrostatic Reduction

Your TreadClimber® machine may develop a static charge caused by the movement of the walking belts. Follow this procedure to apply an anti-static spray to them to reduce the static electric charges.

 Wait a minimum of 60 minutes after the last workout before you apply the anti-static spray, to let hot components cool to room temperature.

1. Remove the batteries from the Console.

2. Carefully apply the anti-static spray to lightly cover the top surface of the walking belts along the front third of the machine.

NOTICE: Hold the spray dispenser approximately 6" (13 cm) above the walking belt and point the spray toward the front of the machine, away from the motor. Apply the spray only on the belts, not on the deck or mechanism. If spray goes off the belts, wipe the excess spray off the other parts of the machine.

Note: Be sure to obey the manufacturer safety instructions for the anti-static product.

3. Using your foot, manually advance the walking belts toward the back of the machine, exposing the next unsprayed section.

4. Do steps 2 and 3 again until all sections of the belts are lightly coated with anti-static spray.

5. Wait until the belts are fully dry (approximately 2-4 hours).

6. Inspect the walking belt alignment and tension before using the machine. Refer to the walking belt adjustment and belt tension check procedures.

7. Install the batteries into the Console.

Note: Repeat the procedure to apply anti-static spray if static electric discharge occurs again. The machine will accumulate more static electric charge when the surrounding air is drier. Be sure to obey the manufacturer safety instructions for the anti-static product.

Troubleshooting

Condition/Problem	Things to Check	Solution
1. Console will not power up/turn on/start	1.1 Batteries	Make sure batteries are installed correctly. If batteries are correctly installed, replace with a set of new batteries.
	1.2 Speed Sensor	Machine will not start if Speed Sensor Magnet is not detected. Check Speed Sensor Magnet and Speed Sensor and make sure they are in place.
2. Speed displayed is not accurate	2.1 Display set to wrong unit of measure. (English/Metric)	Change display units.
	2.2 Console Setting "EdgE" (if equipped)	Adjust the Speed Detection setting ("EdgE") on the Console to the other option (see "Console Service/Setup Mode" procedure).
	2.3 Speed Sensor Assembly	Replace Speed Sensor Assembly.
3. Speed displayed is always "0"/ stuck in Pause mode	3.1 Speed Sensor Cable	Make sure the Speed Sensor Cable is connected to the back of the Console and the Treadle Assembly near the Flywheel Assembly.
	3.2 Speed Sensor Magnet and Speed Sensor Assembly	Check Speed Sensor Magnet and Speed Sensor Assembly to make sure they are in place.
	3.3 Console Assembly	Replace Console Assembly.
4. Walking belt misalignment	4.1 Rear belt guides	Belts should ride on top of triangular black belt guides at rear of Treadles.
	4.2 Tracking adjustment	Belts are not required to be perfectly centered and are typically farther out in the rear than they are in the front. This may vary depending on user's stride. If belt is tracking to one side far enough to cause a scraping sound or belt wear (fraying), follow belt alignment procedure in Owner's Manual.
5. Speed dependent grinding or scraping noise	5.1 Belt alignment	Check walking belt alignment. Belt contact with metal guides under Treadle can make a loud grinding sound. If belts are misaligned, adjust walking belt.
	5.2 Rollers	Contact Customer Care for further assistance.
6. Hesitation or belt slipping when walking on unit	6.1 Walking belt tension	Adjust walking belt tension by following the "Adjusting the Walking Belts" procedure.
	6.2 Lubrication	Consult lubrication chart and apply as necessary.
7. "Tick" sound once per revolution or scraping noise from under Treadle	7.1 Belt alignment	Belt seam may be contacting metal belt guide under Treadle. Slight adjustment of belt should alleviate noise. Follow the "Adjusting the Walking Belts" procedure.
8. Treadles do not operate correctly	8.1 Dependency and Heim Joint	Consult "One Way Bearing Inspection and Adjustment" and "Heim Joint Inspection" procedures.
	8.2 Treadles	Contact Customer Care for further assistance.
9. Console displays "bAtt"	9.1 Batteries	Batteries are below 10% of their rated power. Replace batteries.

Console Service / Setup Mode

From the Power Up/Idle Mode, push and hold the START/STOP and SCAN buttons for 3 seconds to access the Console Service/Setup Mode.

Display	Option	Description
UnIt	Units	Select your preferred unit of measurement; "Lb" = English Imperial, "SI" = metric
StAt	Statistics	Displays the total time, calories, and distance the machine has been used since it was activated or the last reset. Note: Push and hold the SCAN button to reset and erase the statistics.
COdE	Firmware Version	Displays the firmware version
bAtt	Battery Voltage	Displays the percent of battery power remaining
EdgE	Speed Detection	Select between modes; "0" = 1 point, "1" = 2 points

Push the SCAN button to cycle through the Options, and push START/STOP to select the Option.

Use the SCAN button to view the details of the Option, and push the START/STOP button to confirm your selection. For options without details to cycle through, push the START/STOP button to exit the option.

To exit the Console Service/Setup Mode, push and hold the START/STOP button for 3 seconds.

Note: The fitness machine can not be immediately shut off from the Console Setup Mode. The user must exit Console Setup Mode, and then push and hold START/STOP for 3 seconds.

Part Replacement

Replacing the Console Top with Electronics Assembly

⚠ DANGER To reduce the risk of electrical shock or unsupervised usage of the equipment, always remove the batteries from the machine and wait 5 minutes before cleaning, maintaining or repairing the machine.

Tools Required: #2 Phillips Screwdriver

1. Disconnect the Speed Sensor Cable from below the Console Assembly.
2. Remove the Speed Sensor Cable from the tabs on the the Console Assembly.

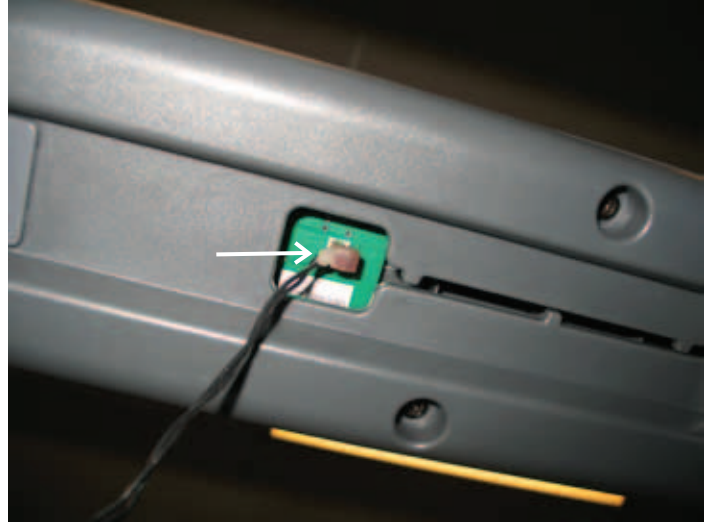

3. Remove the 8 indicated Phillips head screws securing the Console Top with Electronics Assembly to the Console Shroud.
4. Carefully remove the Console Top with Electronics Assembly from the front of the Console Shroud.
5. Install the new Console Top with Electronics Assembly.
6. Reinstall the 8 Phillips head screws.
7. Connect the Speed Sensor Cable and route the cable behind the tabs.

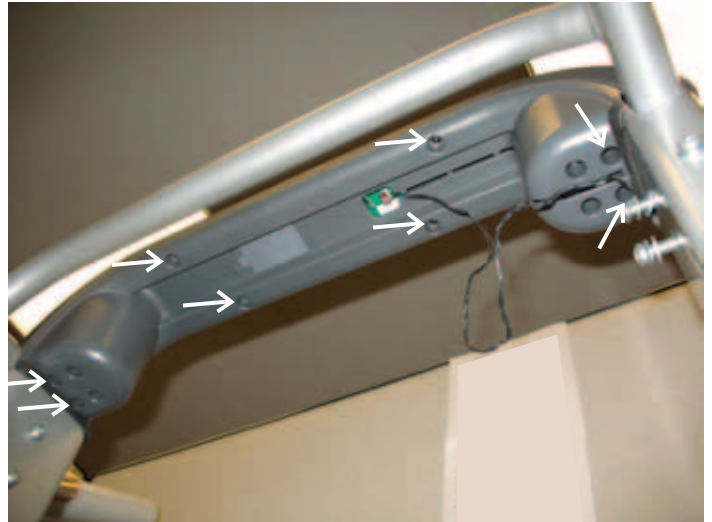

Replacing the Console Assembly / Console Shroud

⚠ DANGER

To reduce the risk of electrical shock or unsupervised usage of the equipment, always remove the batteries from the machine and wait 5 minutes before cleaning, maintaining or repairing the machine.

Tools Required: #2 Phillips Screwdriver, 5 mm hex wrench

Note: If only replacing the Console Shroud, use the Console Top with Electronics Assembly replacement instructions to transfer the electronics to the new Console Shroud.

1. Disconnect the Speed Sensor Cable from below the Console Assembly.
2. Remove the Speed Sensor Cable from the tabs on the the Console Assembly.

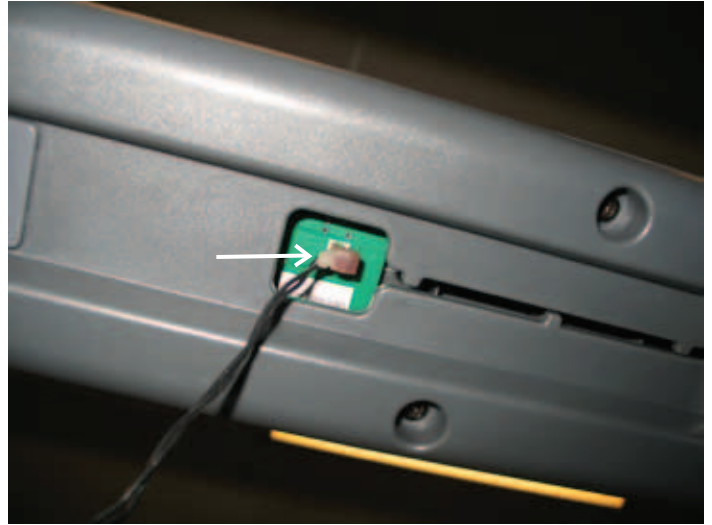

3. Remove the 6 indicated screws from the Console Assembly using a 5 mm hex wrench.

4. Lift the Console Assembly off of the Junction Covers and Uprights.

Note: Be aware of how the Speed Sensor Cable routes through the Console Assembly for replacement purposes.

5. Installation is the reverse procedure.



Replacing the Drive Belt

⚠ DANGER

To reduce the risk of electrical shock or unsupervised usage of the equipment, always remove the batteries from the machine and wait 5 minutes before cleaning, maintaining or repairing the machine.

Tools Required: short #2 Phillips Screwdriver, #2 Phillips Screwdriver, 16 mm wrench

1. Remove the 4 indicated screws from the Front Cover using a short #2 Phillips Screwdriver and a standard #2 Phillips Screwdriver.

2. Remove the Front Cover.

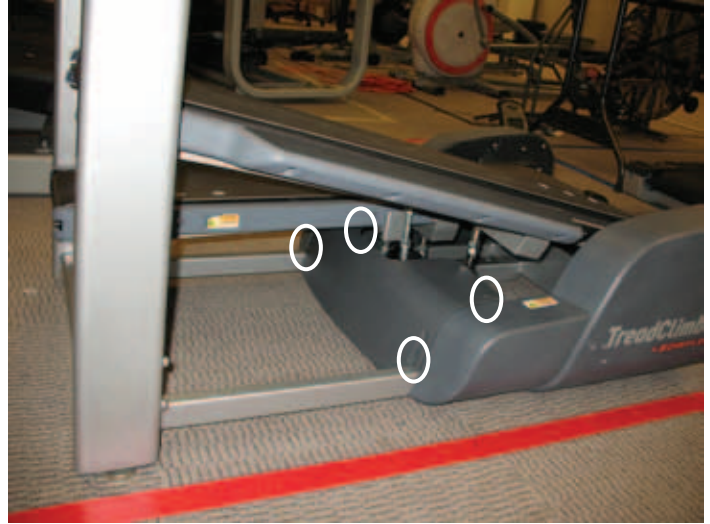

3. Using a #2 Phillips screwdriver, remove the 4 indicated screws from the Rear Cover and remove it.



4. Using a #2 Phillips screwdriver, remove the 5 indicated screws from the Left Side Cover and remove it.



5. Using a 16 mm wrench, loosen the Belt Tensioner Bolt until the Drive Belt is slack.

Note: Count the visible Belt Tensioner Bolt threads before loosening to assist with reassembly.

6. Turn the Drive Pulley clockwise while forcing the Drive Belt to the outside. Belt will come off of the Drive Pulley and Rear Roller Pulley.

 Keep fingers out of any pinch opportunities when turning the Pulleys.

Note: Chain guard is not shown in images.

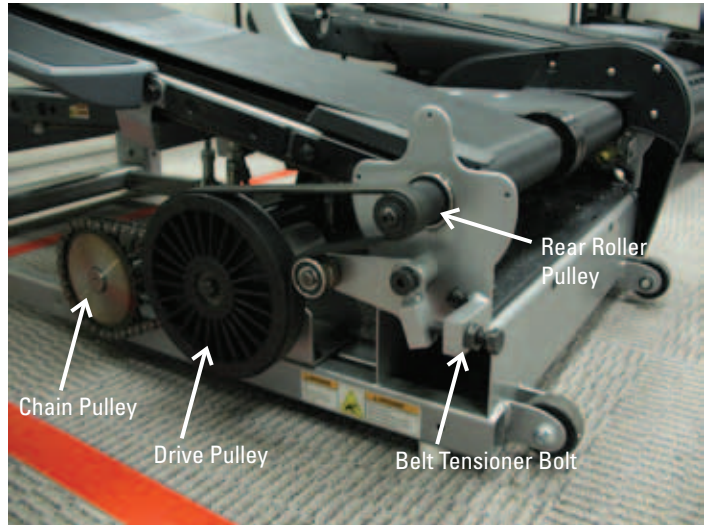

7. Wrap the new Drive Belt around the Rear Roller Pulley. Start the Drive Belt on the Drive Pulley and roll it in a clockwise motion. Be sure the Belt does not come off of the Rear Roller Pulley.

 Keep fingers out of any pinch opportunities when turning the Pulleys.

8. Roll the Drive Pulley clockwise until the Drive Belt is fully installed. Continue to roll the Belt forward while adding side pressure with fingers to align as necessary.

9. Replace the Left Side Cover and secure with screws.

10. Replace the Rear Cover and secure with screws.

11. Replace the Front Cover and secure with screws.



Removing the Treadle Assembly

⚠ DANGER

To reduce the risk of electrical shock or unsupervised usage of the equipment, always remove the batteries from the machine and wait 5 minutes before cleaning, maintaining or repairing the machine.

Tools Required: Short #2 Phillips screwdriver, #2 Phillips Screwdriver, 5 mm hex wrench, 6 mm hex wrench, 13 mm (1/2") wrench, 16 mm wrench, 18 mm wrench, 19 mm wrench

1. Remove the 4 indicated screws from the Front Cover using a short #2 Phillips Screwdriver and a standard #2 Phillips Screwdriver.
2. Remove the Front Cover.

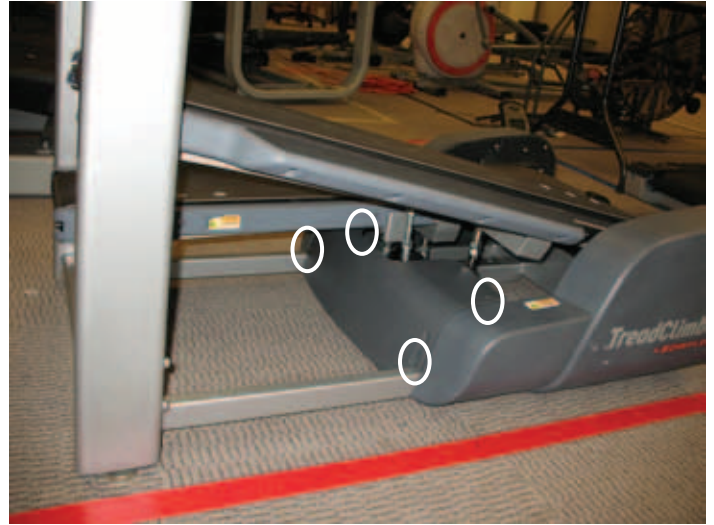

3. Using a #2 Phillips screwdriver, remove the 4 indicated screws from the Rear Cover and remove it.



4. Using a #2 Phillips screwdriver, remove the 5 indicated screws from the Left Side Cover and remove it.



5. Disconnect the Speed Sensor Cable from the Speed Sensor.

6. Using a #2 Phillips screwdriver, remove the 5 screws from the Right Side Cover and remove it.

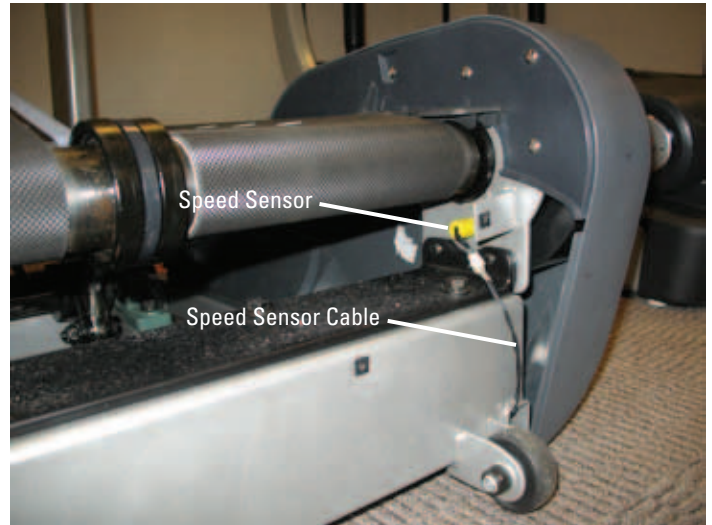

7. Using a 6 mm hex wrench, remove the indicated bolt from the Flywheel.

Note: Push down and hold the Walking Belt still when removing the bolt. Be sure to observe the Speed Sensor Magnet orientation on the Flywheel Assembly for re-assembly.

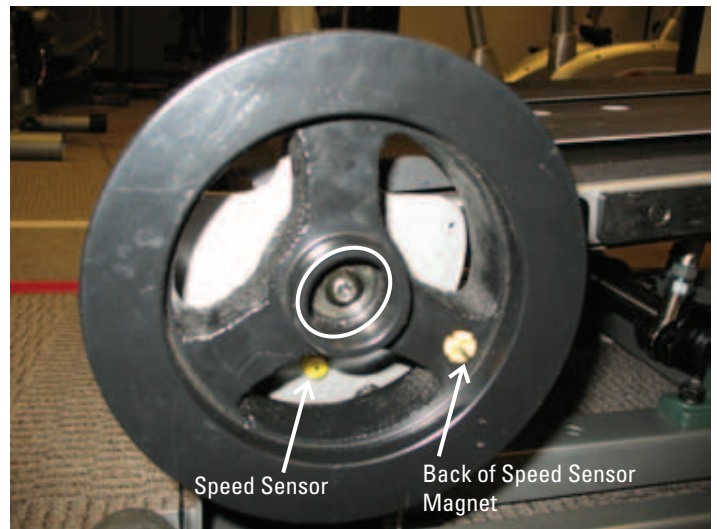

8. Adjust the Treadles until they are at the same height, and place a static object (like a book or box) under the Treadles to support them.

 The Treadle will fall abruptly if not supported. Keep hands away from the inside of the Treadles to avoid possible serious injury.

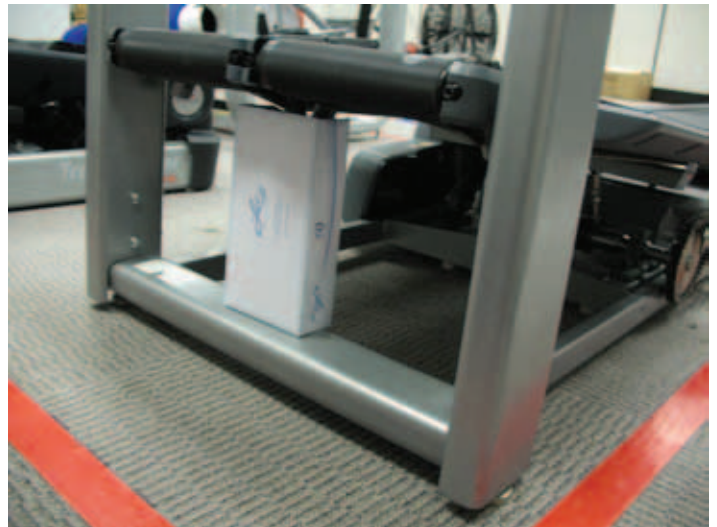

9. Using a 18 mm and a 19 mm wrench, disconnect the indicated hardware from each of the One Way Bearing Joints.

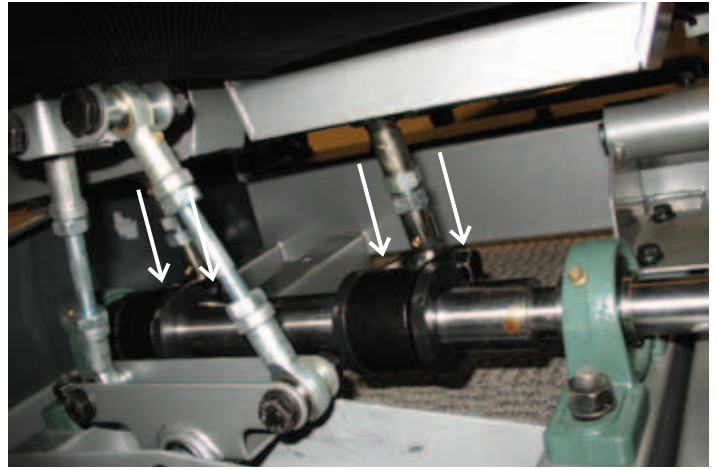

10. Using a 5 mm hex wrench and a 13 mm (1/2") wrench, remove the Hardware from the Dependency.

Note: Be sure to observe the order of hardware to assist with re-assembly.

 The Treadle will fall abruptly if not supported. Keep hands away from the inside of the Treadles to avoid possible serious injury.s.

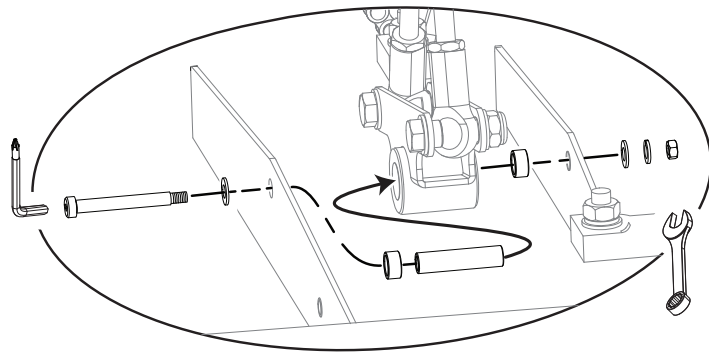

11. Using a 16 mm wrench, loosen the Belt Tensioner Bolt until the Drive Belt has slack.

Note: Count Belt Tensioner Bolt threads before loosening.

12. Turn the Drive Pulley clockwise while forcing the Drive Belt to the outside. Belt will come off of the Drive Pulley and Rear Roller Pulley.

 Keep fingers out of any pinch opportunities when turning the Pulleys.

Note: Chain guard is not shown in images.

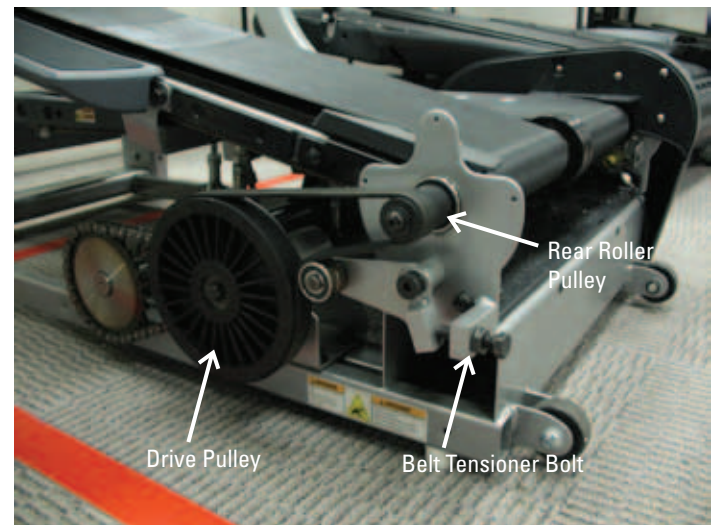

13. Using a 13 mm (1/2") wrench, remove the indicated four bolts from the Base Assembly.

14. Carefully lift the Treadle Assembly off the Base Assembly.

Note: THIS STEP REQUIRES TWO PEOPLE.

 Do not move the machine without aid. Injury to you or damage to the machine can occur. The Treadles and Walking Belts can abruptly move. To avoid possible serious injury, keep hands away from the inside of the Treadles and the edges of the Walking Belts.

 The Walking Belts can abruptly move. To avoid possible serious injury, keep hands away from the edges of the Walking Belts.

15. Installation is the reverse procedure.

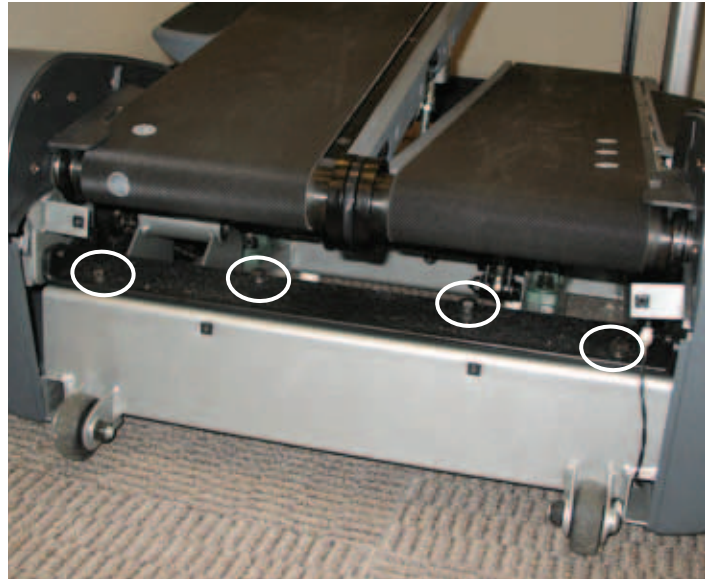

Replacing the Walking Deck

⚠ DANGER

To reduce the risk of electrical shock or unsupervised usage of the equipment, always remove the batteries from the machine and wait 5 minutes before cleaning, maintaining or repairing the machine.

Tools Required: Short #2 Phillips screwdriver, #2 Phillips Screwdriver, 5 mm hex wrench, 16 mm wrench

1. Remove the 4 indicated screws from the Front Cover using a short #2 Phillips Screwdriver and a standard #2 Phillips Screwdriver.
2. Remove the Front Cover.

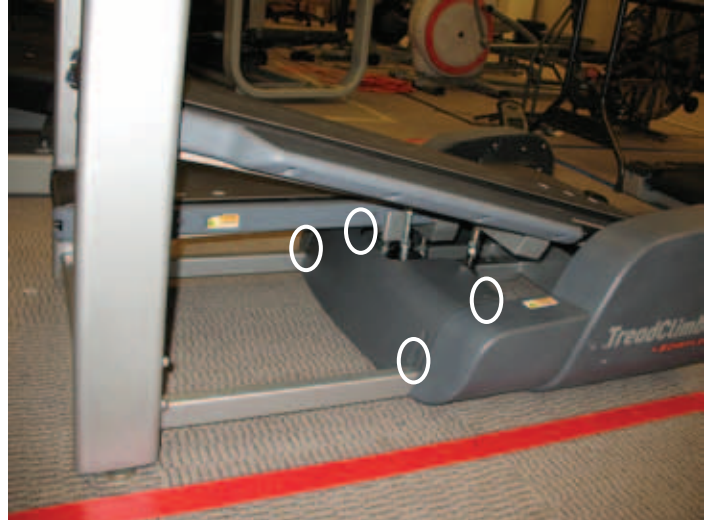

3. Using a #2 Phillips screwdriver, remove the 4 indicated screws from the Rear Cover and remove it.



4. Using a #2 Phillips screwdriver, remove the 5 indicated screws from the Left Side Cover and remove it.



5. Using a #2 Phillips screwdriver, remove the 5 screws from the Right Side Cover and remove it.

6. Using a 16 mm wrench, loosen the Belt Tensioner Bolt until the Drive Belt has slack.

Note: Count Belt Tensioner Bolt threads before loosening.

7. Turn the Drive Pulley clockwise while forcing the Drive Belt to the outside. Belt will come off of the Drive Pulley and Rear Roller Pulley.

 Keep fingers out of any pinch opportunities when turning the Pulleys.

Note: Chain guard is not shown in images.

8. Loosen the Belt Tensioning Screws and Brackets using a 5 mm hex wrench.

NOTE: Be sure to record how many turns it takes to remove the screws to assist with reassembly.

9. With the Walking Belt loose, shift the belt to the outside and remove the 4 deck screws using a #2 Phillips screwdriver.

NOTE: Be sure to record how many turns it takes to remove the screws to assist with reassembly.

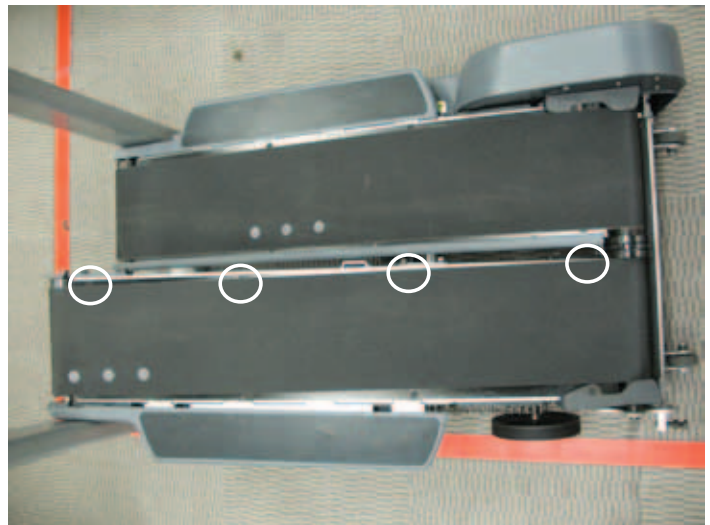
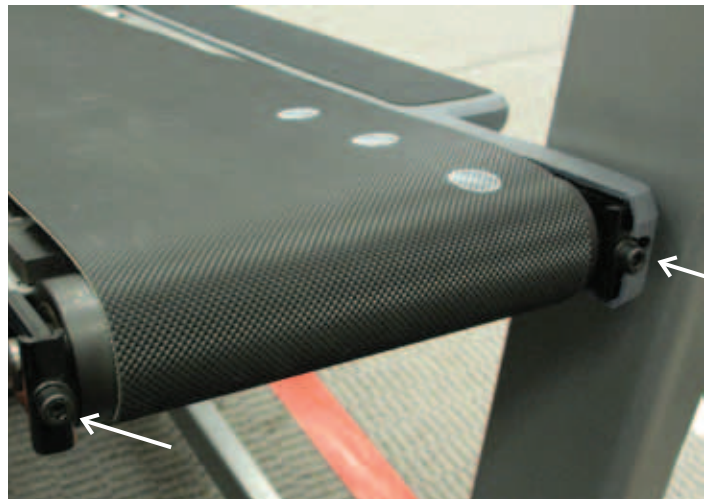
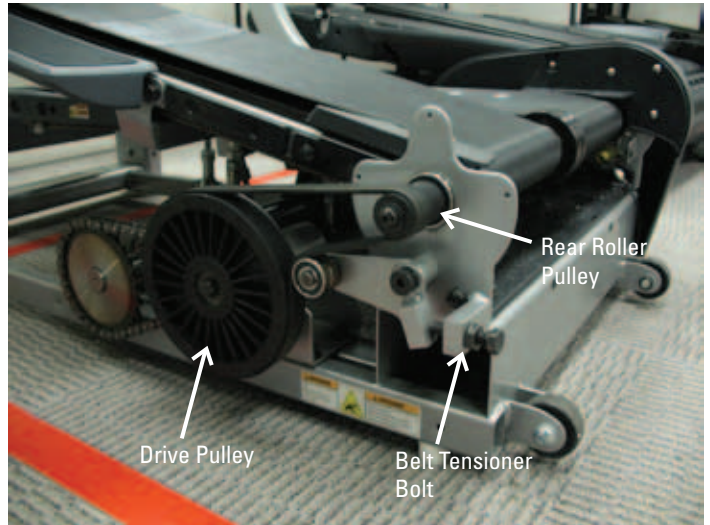

10. Shift the belt to the center of the machine and remove the 3 deck screws and 1 belt guide screw using a #2 Phillips screwdriver.

11. Lift the belt slightly and slide the Walking Deck out from under the belt.

12. Slide the new deck in with the laminated side facing up.

13. Repeat procedure on the other side of machine if replacing both Walking Decks.

14. Reassembly is the reverse procedure.

Be sure to consult the WALKING BELT ADJUSTMENT procedure.

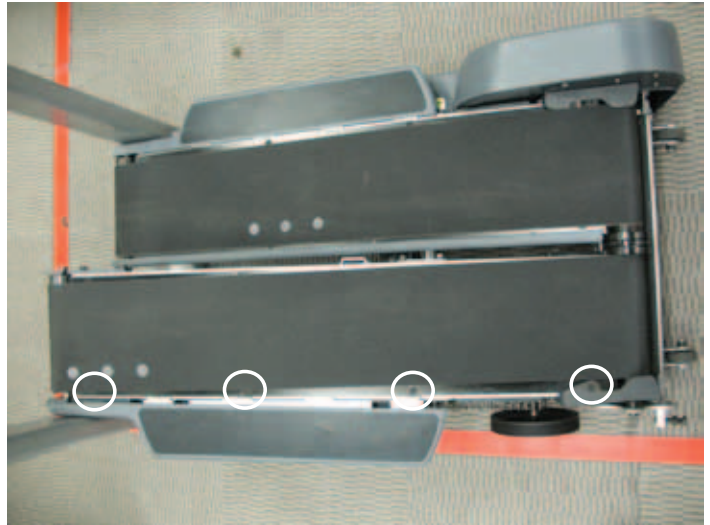

Replacing the Front Roller

⚠ DANGER To reduce the risk of electrical shock or unsupervised usage of the equipment, always remove the batteries from the machine and wait 5 minutes before cleaning, maintaining or repairing the machine.

Tools Required: #2 Phillips Screwdriver, 5 mm hex wrench, (2) 13 mm wrenches

1. Using a #2 Phillips screwdriver, remove the 4 screws from the Right Side Cover and slide it forward.

Note: The Side Cover can not be removed and only needs to be slid forward.



2. Using a #2 Phillips screwdriver, remove the 5 indicated screws from the Inside Treadle Cover and remove it.



3. Remove the Belt Tensioning Screws and Brackets using a 5 mm hex wrench.

NOTE: Be sure to record how many turns it takes to remove the screws to assist with reassembly

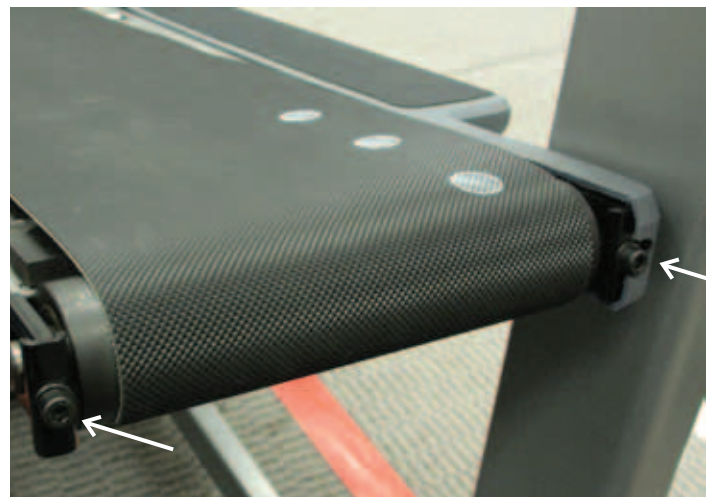

4. Using two 13 mm (1/2") wrenches, remove the indicated bolts from the Treadle.

5. Remove the Front Roller by sliding it out of the belt.

6. Repeat procedure on the right side.

7. Installation is the reverse procedure. Be sure to tension belts properly after reassembly following the procedures in the Owner's manual.

Be sure to consult the WALKING BELT ADJUSTMENT procedure.



Replacing the Walking Belt

⚠ DANGER To reduce the risk of electrical shock or unsupervised usage of the equipment, always remove the batteries from the machine and wait 5 minutes before cleaning, maintaining or repairing the machine.

Tools Required: Short #2 Phillips screwdriver, #2 Phillips Screwdriver, 5 mm hex wrench, 6 mm hex wrench, (2) 13 mm (1/2") wrench, 16 mm wrench, 18 mm wrench, 19 mm wrench

1. Remove the 4 indicated screws from the Front Cover using a short #2 Phillips Screwdriver and a standard #2 Phillips Screwdriver.

2. Remove the Front Cover.

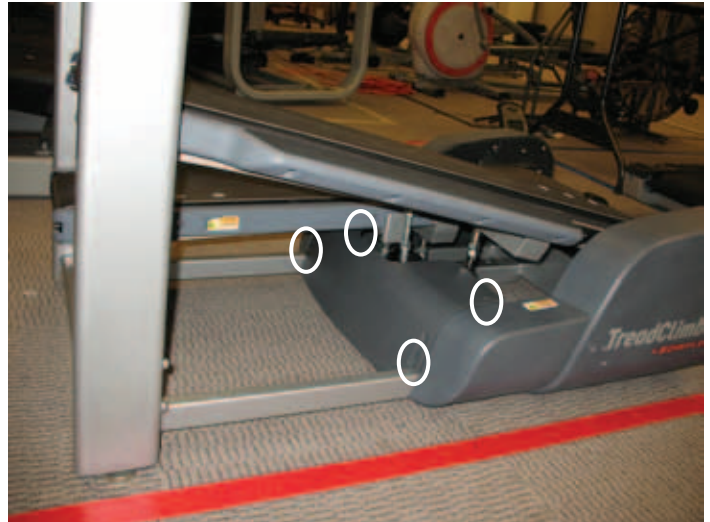

3. Using a #2 Phillips screwdriver, remove the 4 indicated screws from the Rear Cover and remove it.



4. Using a #2 Phillips screwdriver, remove the 5 indicated screws from the Left and Right Pivot Covers.



5. Using a 6 mm hex wrench, remove the indicated bolt from the Flywheel and remove it.

Note: Push down and hold the Walking Belt still when removing the bolt. Be sure to observe the Speed Sensor Magnet orientation on the Flywheel Assembly for re-assembly.

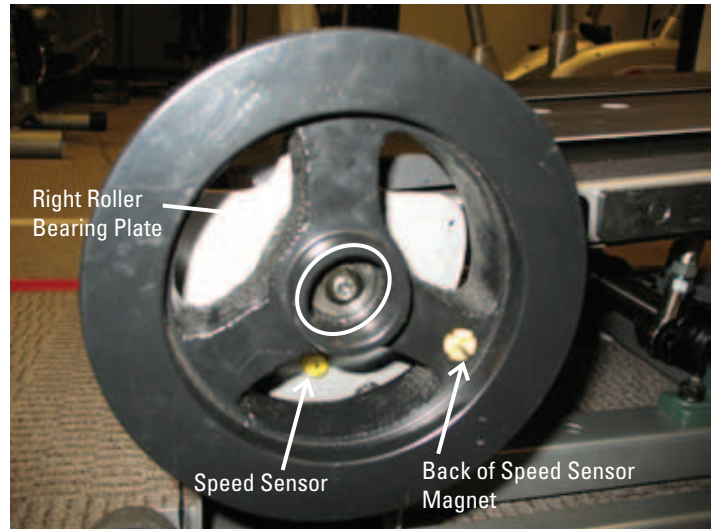

6. Disconnect the Speed Sensor Cable from the Speed Sensor.

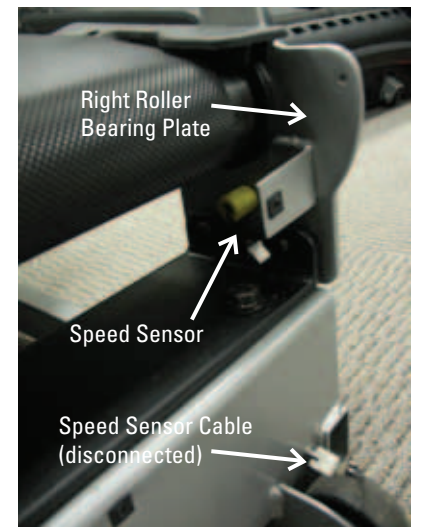

7. Using a 16 mm wrench, loosen the Belt Tensioner Bolt until the Drive Belt is slack.

Note: Count the visible Belt Tensioner Bolt threads before loosening to assist with reassembly.

8. Turn the Drive Pulley clockwise while forcing the Drive Belt to the outside. Belt will come off of the Drive Pulley and Rear Roller Pulley.

 Keep fingers out of any pinch opportunities when turning the Pulleys.

Note: Chain guard is not shown in images.

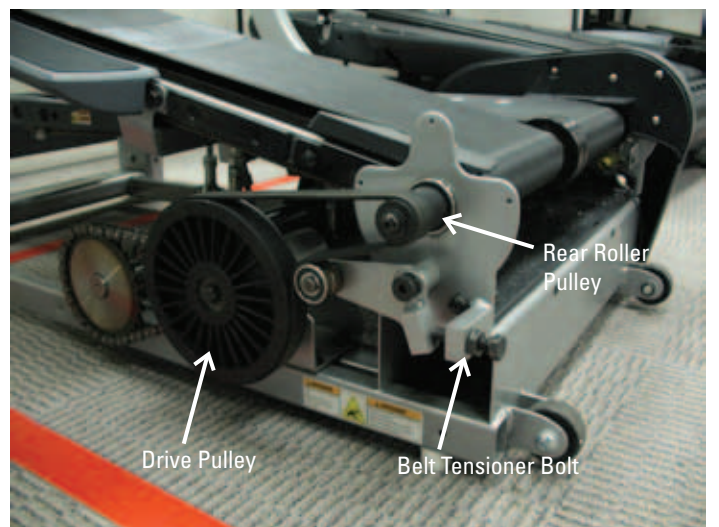

9. Using a #2 Phillips screwdriver, remove the 5 indicated screws from the Inside Treadle Covers.

10. Remove the Inside Treadle Covers.



11. Using a 13 mm (1/2") wrench, remove the indicated bolts from the Treadle Crossbar on the inside of each of the Treadles.



12. Adjust the Treadles until they are at the same height, and place a static object (like a book or box) under the Treadles to support them.

 The Treadle will fall abruptly if not supported. Keep hands away from the inside of the Treadles to avoid possible serious injury.

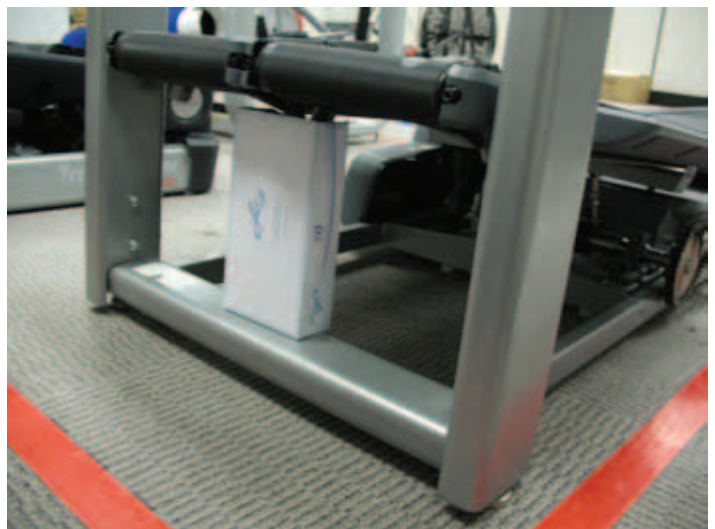

13. Using a 6 mm hex wrench, remove the bolt from the Rear Roller Pulley.

14. Using a 5 mm hex wrench, remove the bolt from the Belt Tensioner Assembly.

15. Using a #2 Phillips screwdriver, remove the Walking Belt Guides from the Decks.

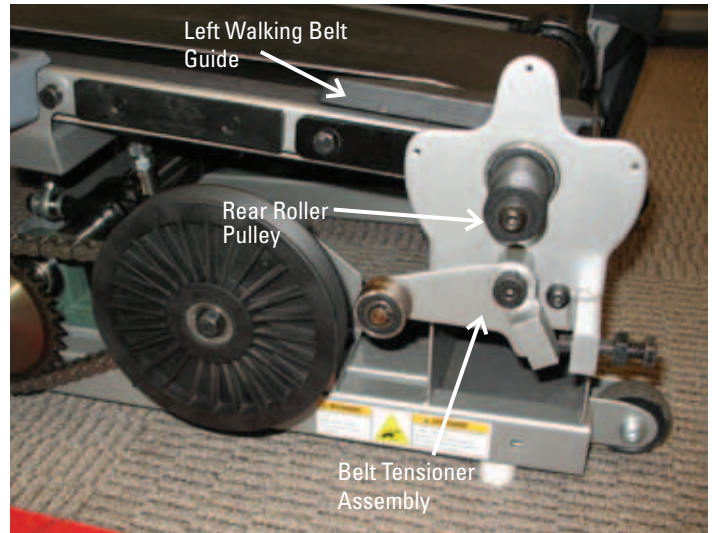

16. Safely rotate the Treadles to the rear of the machine. Place a static object (like a book or box) under the Treadles to support them.

Note: Be sure there is enough room to the rear of the machine before beginning to move the Treadles. THIS STEP REQUIRES TWO PEOPLE.

⚠ Do not move the machine without aid. Injury to you or damage to the machine can occur. The Treadles and Walking Belts can abruptly move. To avoid possible serious injury, keep hands away from the inside of the Treadles and the edges of the Walking Belts.

⚠ The Walking Belts can abruptly move. To avoid possible serious injury, keep hands away from the edges of the Walking Belts.

⚠ The Treadle will fall abruptly if not supported. Keep hands away from the inside of the Treadles to avoid possible serious injury.

⚠ Keep fingers out of any pinch opportunities when flipping the Treadles.

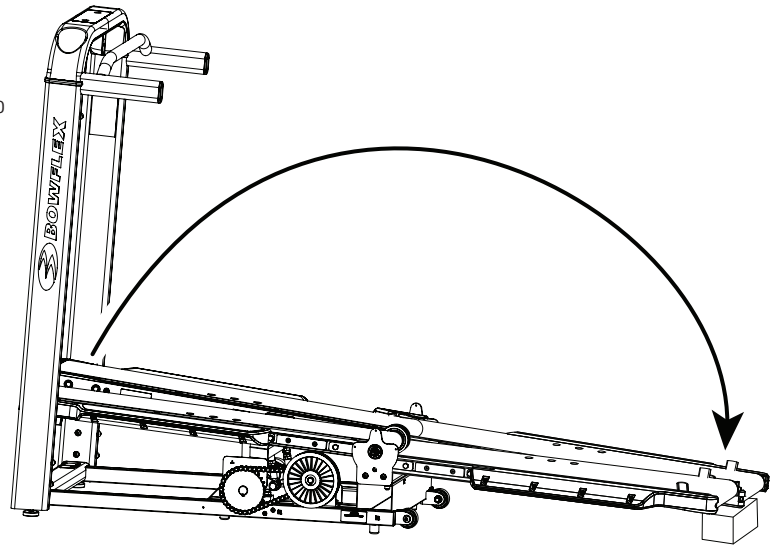

Note: Images show the Treadles in normal configuration, but operation must have them rotated to the rear of the machine.

17. Using a #2 Phillips screwdriver, remove the 4 screws holding the Left and Right Side Covers to the Treadles.

18. Remove the Left and Right Side Covers.

19. Using a 13 mm (1/2") wrench, remove the indicated bolts from the Treadle Crossbar on the outside of each of the Treadles.



20. Remove the Belt Tensioning Screws and Brackets using a 5 mm hex wrench.

NOTE: Be sure to record how many turns it takes to remove the screws to assist with reassembly

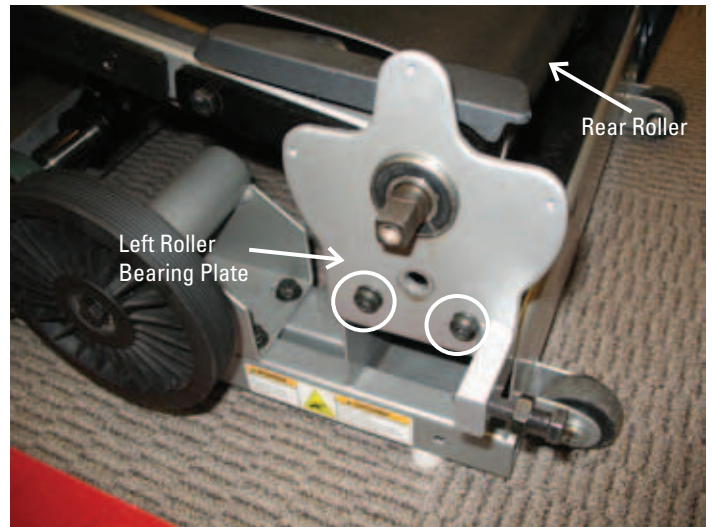

21. Using a 5 mm hex wrench, remove the Belt Tensioning Screws and Brackets from the Front Roller.

NOTE: Be sure to record how many turns it takes to remove the screws to assist with reassembly. Also note the orientation of the Brackets. The larger Bracket is to the outside of the machine.

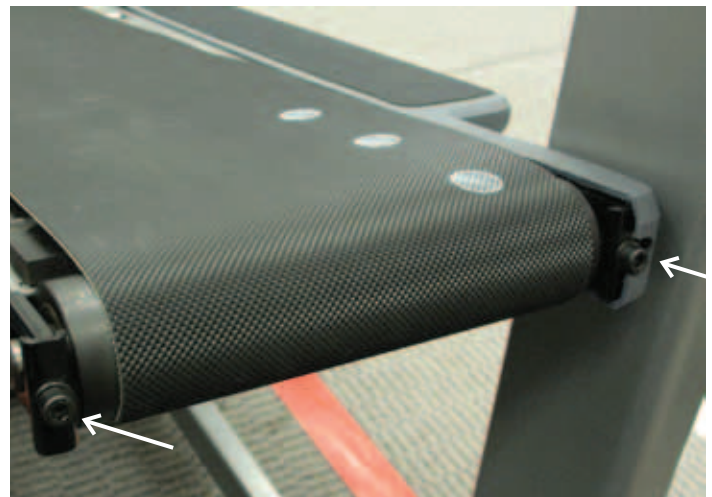

22. Place a static object (like a book or box) under the Rear Roller of the Right Treadle. This will support the weight of the Treadle Assembly when the Left Roller Bearing Plate is removed.

23. Using a 5 mm hex wrench, remove the indicated bolts from the Left Roller Bearing Plate.

24. Remove the Left Roller Bearing Plate from the Rear Roller.

25. Carefully slide the Walking Belt off of the deck and replace with new belt.

26. Follow the same procedure for replacing the right Walking Belt.

27. Installation is the reverse procedure.

Be sure to consult the WALKING BELT ADJUSTMENT procedure.

Replacing the Dependency

⚠ DANGER To reduce the risk of electrical shock or unsupervised usage of the equipment, always remove the batteries from the machine and wait 5 minutes before cleaning, maintaining or repairing the machine.

Tools Required: Short #2 Phillips screwdriver, #2 Phillips Screwdriver, (2) 13 mm wrenches, 5 mm hex wrench

1. Remove the 4 indicated screws from the Front Cover using a short #2 Phillips Screwdriver and a standard #2 Phillips Screwdriver.

2. Remove the Front Cover.

3. Using a #2 Phillips screwdriver, remove the 4 indicated screws from the Rear Cover and remove it

4. Using a #2 Phillips screwdriver, remove the 5 indicated screws from the Left and Right Covers.

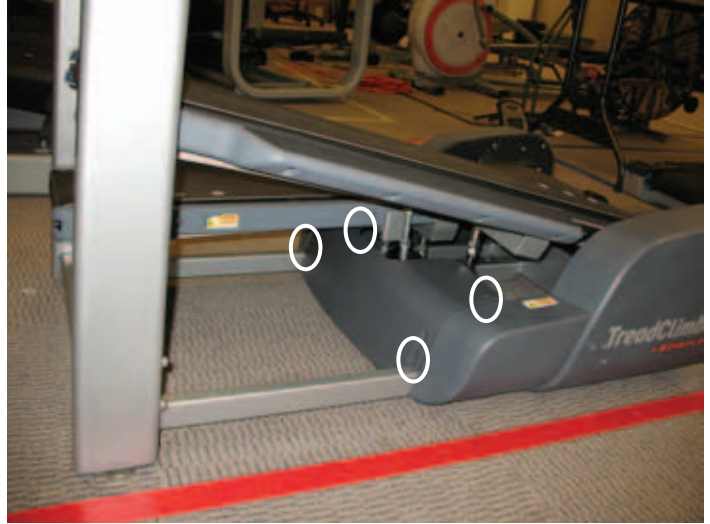

5. Adjust the Treadles until they are at the same height, and place a static object (like a book or box) under the Treadles to support them.

 The Treadle will fall abruptly if not supported. Keep hands away from the inside of the Treadles to avoid possible serious injury.

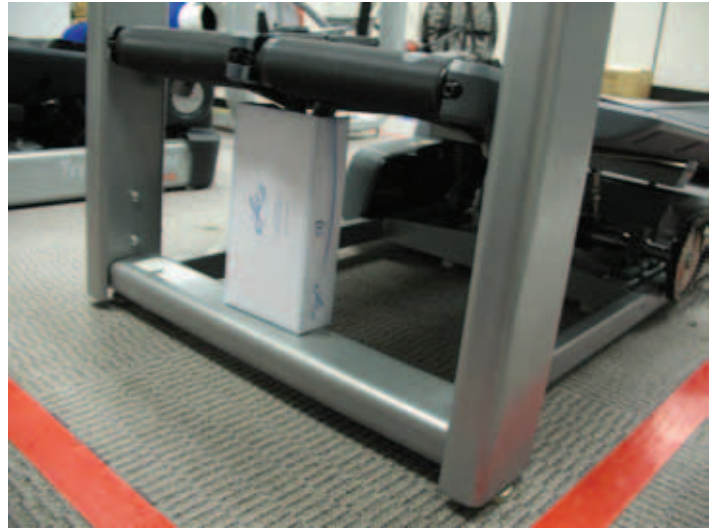

6. Using a 5 mm hex wrench and a 13 mm (1/2") wrench, remove the Hardware from the Dependency.

Note: Be sure to observe the order of hardware to assist with re-assembly.

 The Treadle will fall abruptly if not supported. Keep hands away from the inside of the Treadles to avoid possible serious injury.

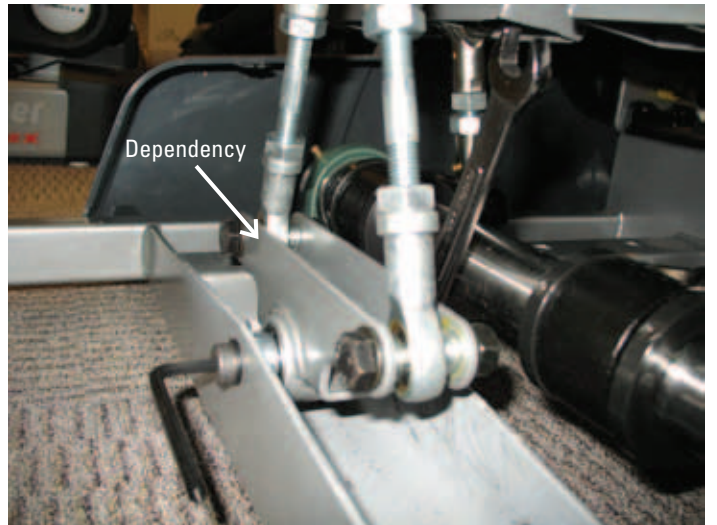
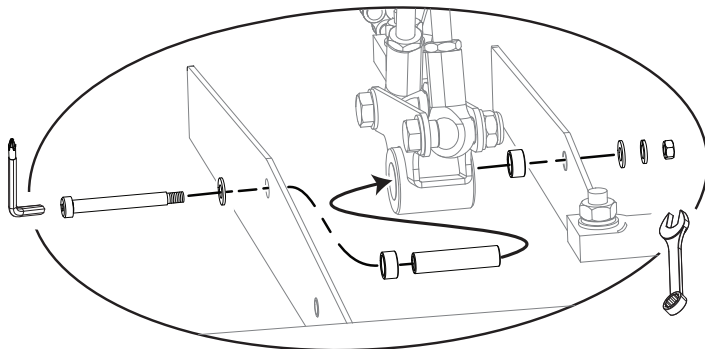

7. Using two 13 (1/2") wrenches, remove the indicated hardware from each of the Dependency/Treadle connections.

8. Remove the old Dependency Assembly and replace with the new assembly.

Note: Be sure the orientation is the same as the old Dependency Assembly.

9. Installation is the reverse procedure.



Replacing the Main Drive Assembly

⚠ DANGER

To reduce the risk of electrical shock or unsupervised usage of the equipment, always remove the batteries from the machine and wait 5 minutes before cleaning, maintaining or repairing the machine.

Tools Required: 5 mm hex wrench, Short #2 Phillips screwdriver, #2 Phillips screwdriver, 13 mm wrench, 17 mm wrench, 18 mm wrench, 19 mm wrench, Torque wrench

1. Remove the 4 indicated screws from the Front Cover using a short #2 Phillips Screwdriver and a standard #2 Phillips Screwdriver.
2. Remove the Front Cover.

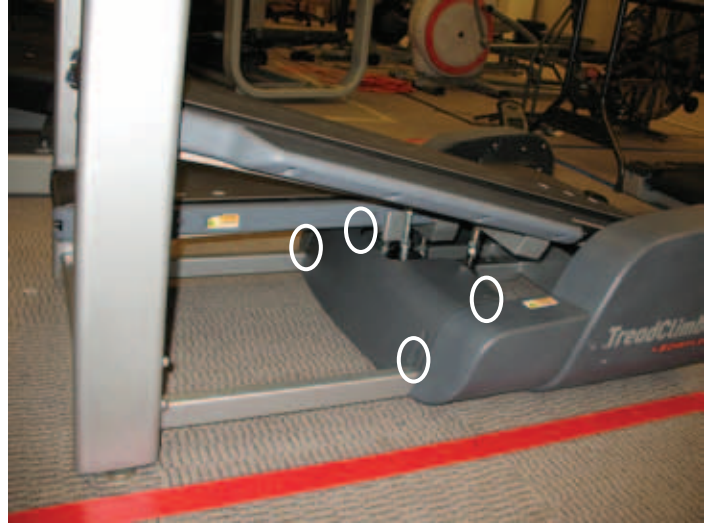

3. Using a #2 Phillips screwdriver, remove the 4 indicated screws from the Rear Cover and remove it



4. Using a #2 Phillips screwdriver, remove the 5 indicated screws from the Left and Right Side Covers.



5. Adjust the Treadles until they are at the same height, and place a static object (like a book or box) under the Treadles to support them.

 The Treadle will fall abruptly if not supported. Keep hands away from the inside of the Treadles to avoid possible serious injury.

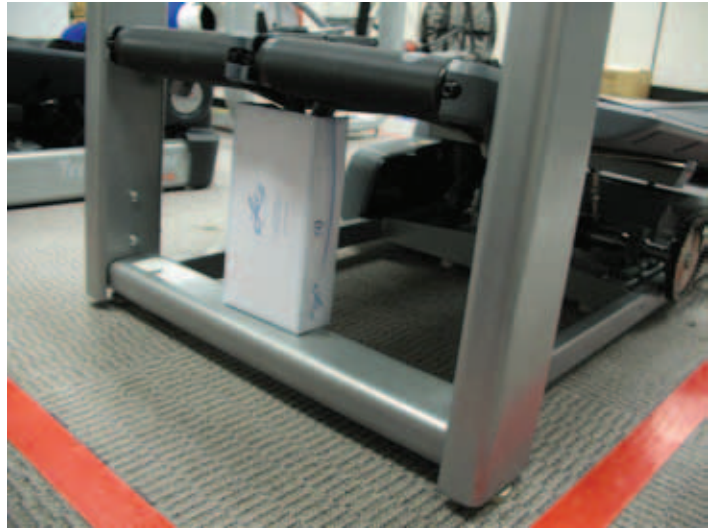

6. Loosen the Belt Tensioner Bolt using a 16 mm wrench.

NOTE: Be sure to record how many turns it takes to remove the screws to assist with reassembly.

7. Turn the Drive Pulley clockwise while forcing the Drive Belt to the outside. Belt will come off of the Drive Pulley and Rear Roller Pulley.

 Keep fingers out of any pinch opportunities when turning the Pulleys.

Note: Chain guard is not shown in photos.

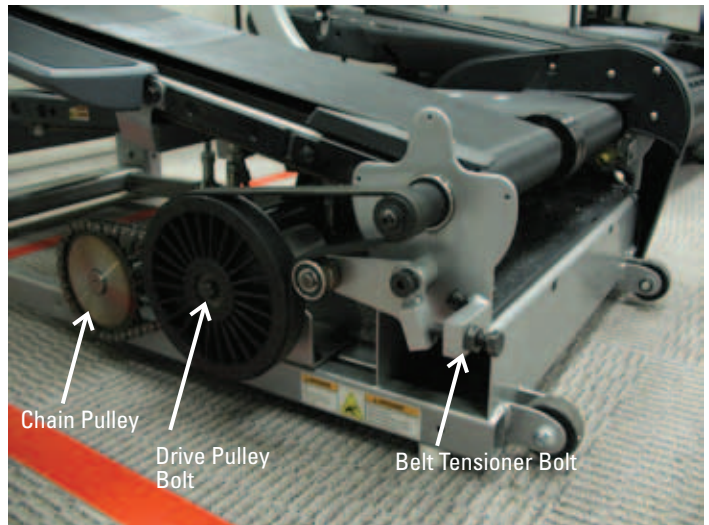

8. Using a #2 Phillips screwdriver, remove the Chain Guard.

 Keep fingers out of any pinch opportunities when removing the Chain.

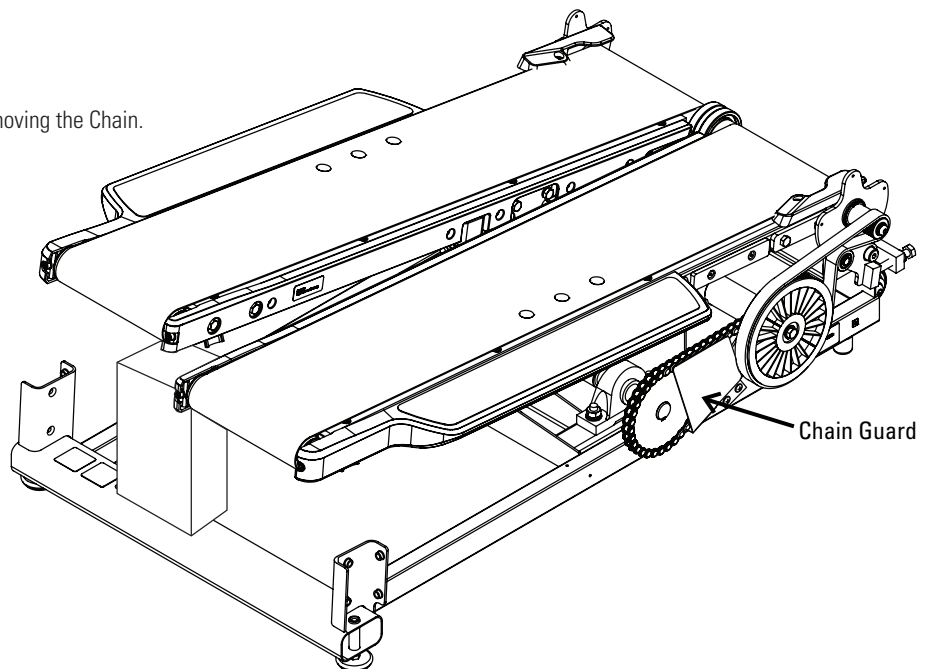

9. Using a 13 mm (1/2") wrench, loosen the indicated bolts that attach the Chain Tensioner Assembly. The Chain Tensioner Assembly is behind the Drive Pulley.

10. Remove Chain from Chain Pulley.



Keep fingers out of any pinch opportunities.

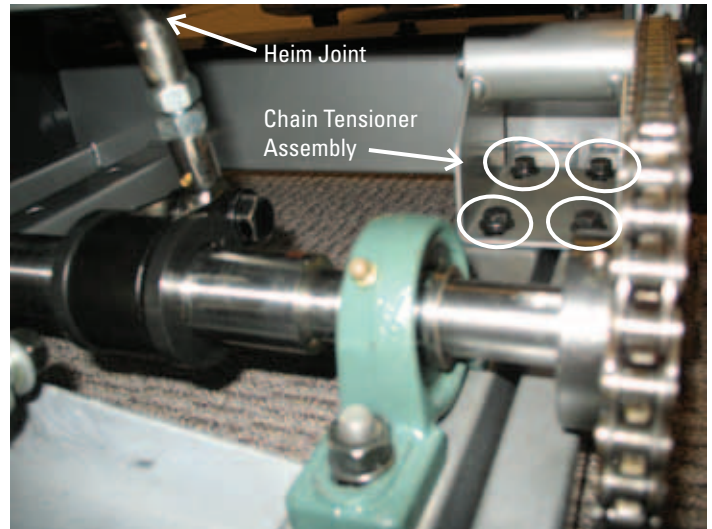

11. Using a 18 mm and a 19 mm wrench, disconnect the indicated hardware from each of the One Way Bearing Joints.

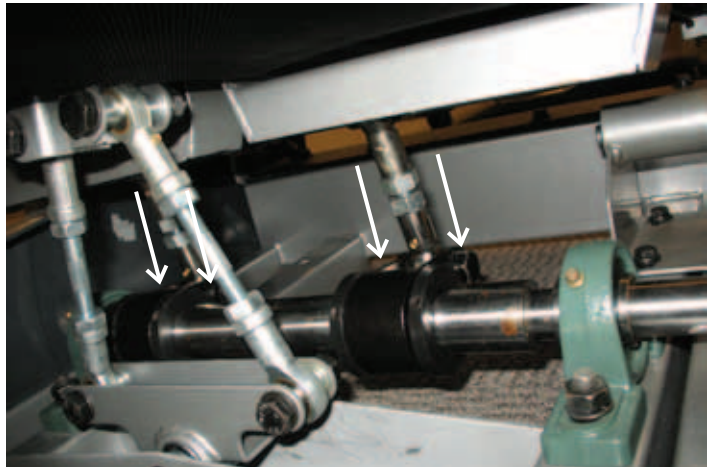

12. Using a 17 mm wrench, remove the indicated hardware from the Main Drive Assembly.

13. Remove the Main Drive Assembly and replace with the new assembly.

Note: Be sure the orientation is the same as the old Main Drive Assembly with the indicated Zerk fittings to the front.



Keep fingers out of any pinch opportunities when placing the Chain around the Chain Pulley on the Main Drive Assembly.



14. Tighten the hardware on the new Main Drive Assembly to 25 N-m.

Note: The new Main Drive Assembly MUST be installed with 11.81 inches (300 mm) from the rear of the Frame Assembly to the rear of the Drive Shaft on the Main Drive Assembly. Be sure the Drive Shaft is parallel to the rear of the Frame Assembly.

15. While pushing the Chain Tensioner Assembly toward the rear of the machine, tighten the hardware.

Note: The Chain should only deflect 8 mm when pushed at the midpoint. Repeat this operation until the Chain is at the correct tension.

16. Fully tighten Hardware on Chain Tensioner Assembly to 17 N-m.

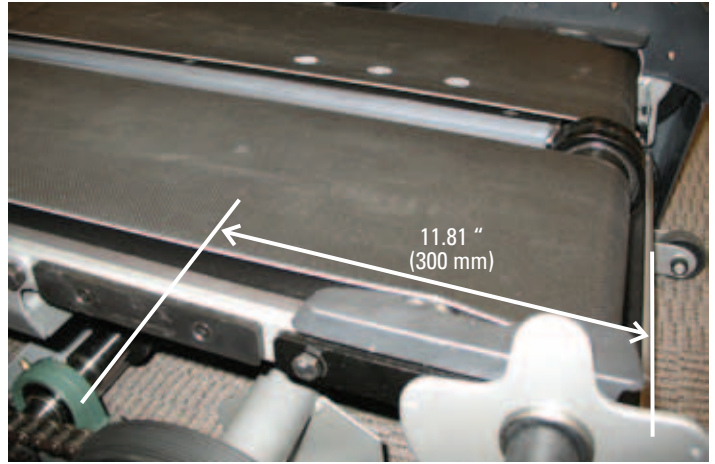

17. Wrap the Drive Belt around the Rear Roller Pulley. Start the Drive Belt on the Drive Pulley and roll it in a clockwise motion. Be sure the Belt does not come off of the Rear Roller Pulley.

 Keep fingers out of any pinch opportunities when turning the Pulleys.

18. Roll the Drive Pulley clockwise until the Drive Belt is fully installed. Continue to roll the Belt clockwise while adding side pressure with fingers to align as necessary.

19. Tighten the Belt Tensioner Bolt until the Drive Belt becomes tight.

Note: Belt should not be over-tightened.

20. Replace the Chain Guard.

21. Replace the Side Covers and secure with hardware.

22. Operate the Treadles to test the tension of the Drive Belt.

Note: if the Drive Belt slips while walking on the Treadles, tighten the Belt Tensioner Bolt from the rear of the machine a quarter turn and repeat test. Repeat this step until Drive Belt does not slip.

 Be sure you have read the "Important Safety Instructions" and "Before You Start" sections in the Owner's Manual before operating the Treadles.

23. Replace the Rear Cover and the Front Cover.

24. Consult the "One Way Bearing Inspection and Adjustment" procedure in the Owner's Manual for proper operation.



Replacing the Speed Sensor Cable

▲ DANGER

To reduce the risk of electrical shock or unsupervised usage of the equipment, always remove the batteries from the machine and wait 5 minutes before cleaning, maintaining or repairing the machine.

Tools Required: #2 Phillips screwdriver, 5 mm hex wrench, #2 Phillips screwdriver

1. Using a #2 Phillips screwdriver, remove the 4 indicated screws from the Rear Cover and remove it



2. Disconnect the Speed Sensor Cable from the Speed Sensor.

3. Connect the new Speed Sensor Cable to the Speed Sensor.

4. Using a piece of wire or string, attach the loose ends of the new Speed Sensor Cable and the old Speed Sensor Cable. The old cable will pull the new cable into place when removed.

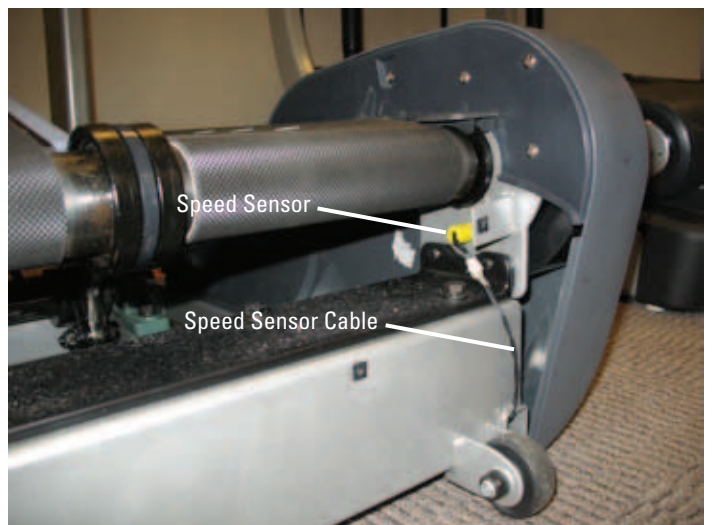

5. Disconnect the Speed Sensor Cable from below the Console Assembly.

6. Remove the Speed Sensor Cable from the tabs on the the Console Assembly.



7. Using a 5 mm hex wrench, remove the 6 indicated bolts from the Uprights.

8. Slowly lift the Console Assembly from the Uprights, noting how the Speed Sensor Cable routes for replacement purposes.

Note: Be sure to notice the orientation of the Junction Covers before removing the Console Assembly, and remove them from the Console Assembly. This will prevent them from falling into the Uprights.



9. Pull the old Speed Sensor Cable from the Upright until the new Speed Sensor Cable is in place.

Note: Be sure not to crimp the cable when pulling it.

10. Disconnect the Cables and attach the new Speed Sensor Cable to the Console.

11. Installation is the reverse of this procedure.

Note: Be sure not to crimp the Speed Sensor Cable.

